

REVISIONS				
ZONE	REV.	DESCRIPTION	DATE	APPROVED
	A	GCF#524673 INITIAL RELEASE	OCT/21/2021	D. ZHANG

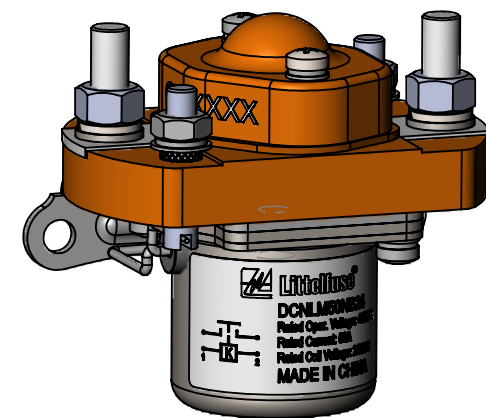

CIRCUIT SCHEMATIC DIAGRAM

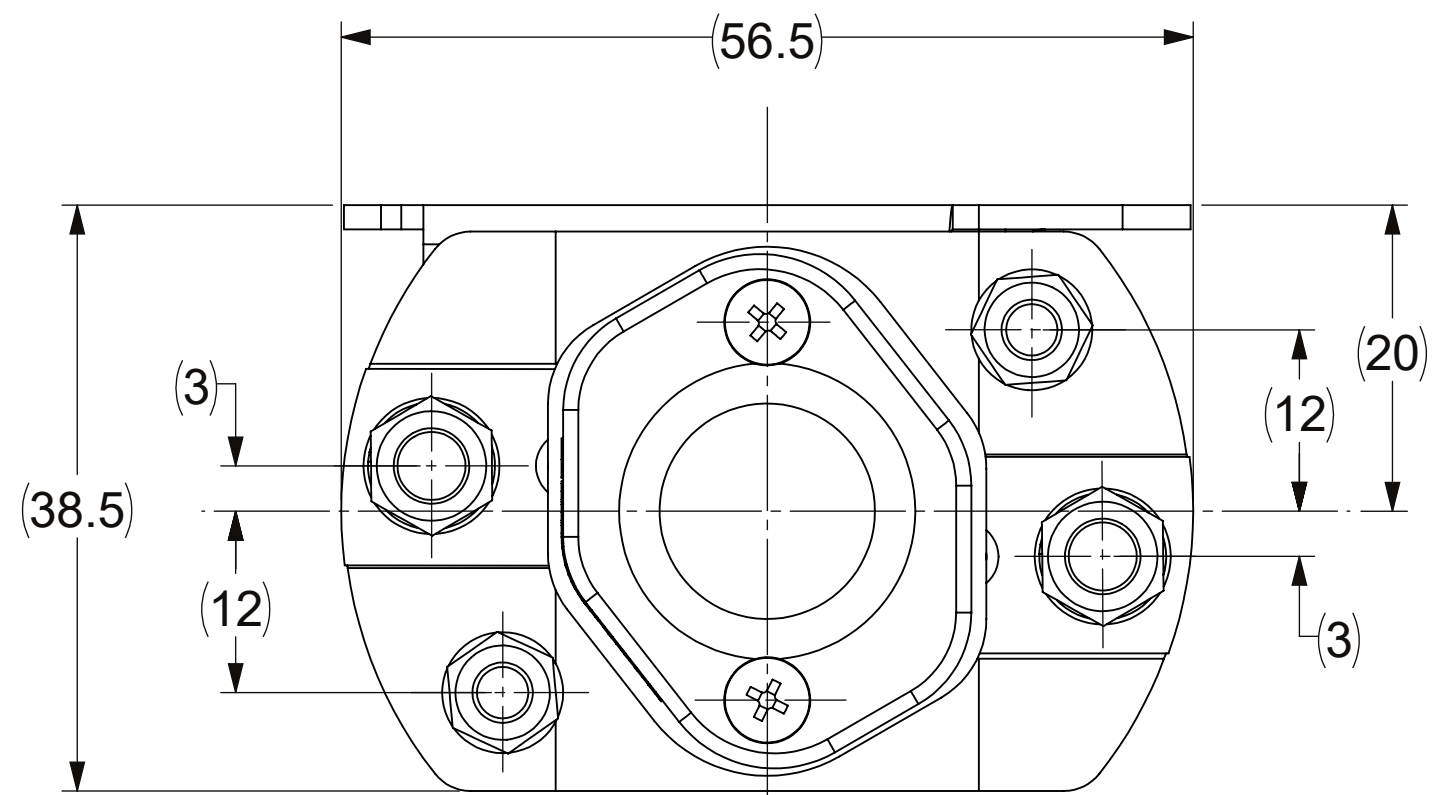
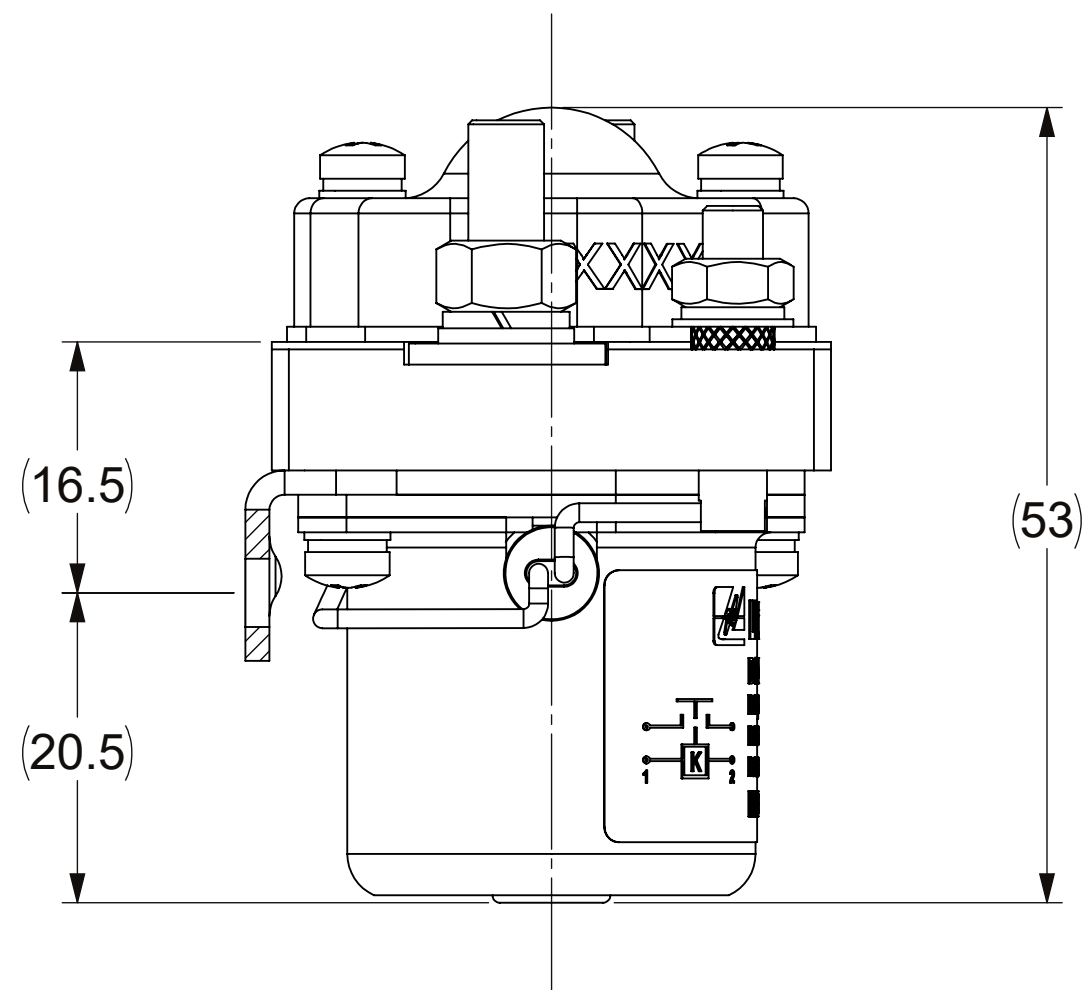
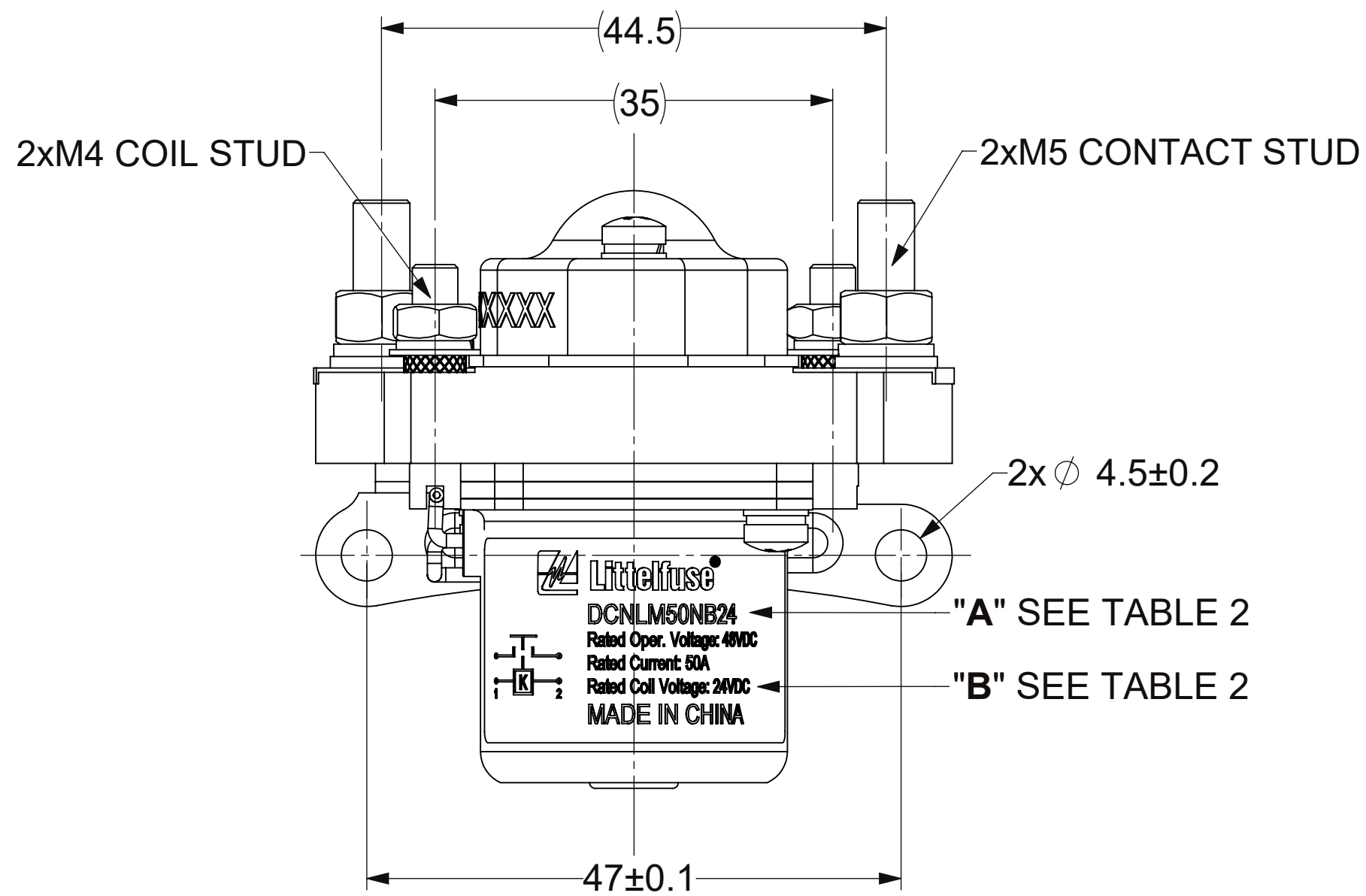
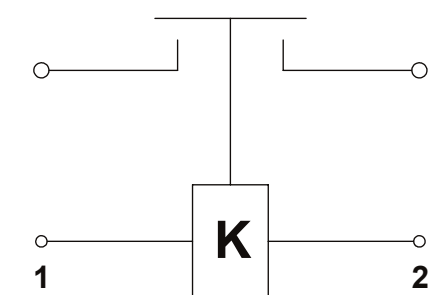

NOTES:

- ALL SIZES ARE FOR REFERENCE ONLY.
- MATERIALS AND FINISH:
 - BASE: THERMOSETTING PLASTIC, UL94V-0.
 - CONTACTS: SILVER ALLOY.
 - COIL STUD: COPPER ALLY, SILVER PLATED.
- PRODUCT TECHNICAL PARAMETERS: SEE TABLE 1.
- PRODUCT AND NAMEPLATE (THE CHARACTER CONTENT AT "A" AND "B") CONFIGURATION SEE TABLE 2.
- CONTACT ARRANGEMENT: SPST-NO.
- CONNECTION STUD: M5 STUD, RECOMMENDED TORQUE 4 N•m ~ 5 N•m; M4 STUD, RECOMMENDED TORQUE 1.7 N•m ~ 2.5 N•m.
- MOUNTING: M4 BOLT, RECOMMENDED TORQUE 1.7 N•m ~ 2.5 N•m.

TABLE 1: TECHNICAL PARAMETERS

ITEM	PARAMETER			
	DCNLM50NB12	DCNLM50NB24	DCNLM50NB48	DCNLM50NB60
RATED COIL VOLTAGE	12V DC	24V DC	48V DC	60V DC
HOLD POWER	MAX 9W	MAX 9W	MAX 9W	MAX 8W
OPERATING VOLTAGE IN COLD STATE AT (20±5)°C	PICK UP	MAX 8.4V DC	MAX 16.8V DC	MAX 33.6V DC
	RELEASE	MIN 1.2V DC	MIN 2.4 V DC	MIN 4.8 V DC
OPERATE TIME	MAX 40ms			
RELEASE TIME	MAX 20ms			
BOUNCE TIME	MAX 7ms			
RATED CONTACT VOLTAGE	48V DC			
MAXIMUM CONTACT VOLTAGE	60V DC			
RATED CONTACT CURRENT	50A			
CONTACT VOLTAGE DROP	≤50mV@50 A			
LIMIT BREAKING ABILITY	4le/5ms, 1CYCLES			
DIELECTRIC STRENGTH	1000V AC, 50Hz, 1min., LEAKAGE CURRENT ≤1 mA			
INSULATION RESISTANCE	≥50MΩ@500VDC			
ELECTRIC LIFE	6000 CYCLES			
MECHANICAL LIFE	100,000 CYCLES			
WORKING DUTY	CONTINUOUS			

TABLE 2: CONFIGURATION OF CHARACTER CONTENT

PRODUCT PN	"A"	"B"
DCNLM50NB12	DCNLM50NB12	Rated Coil Voltage: 12VDC
DCNLM50NB24	DCNLM50NB24	Rated Coil Voltage: 24VDC
DCNLM50NB48	DCNLM50NB48	Rated Coil Voltage: 48VDC
DCNLM50NB60	DCNLM50NB60	Rated Coil Voltage: 60VDC

DIMENSIONS ARE SHOWN IN MILLIMETERS. DIMENSIONS AND TOLERANCES ARE DEFINED ACCORDING TO ANSIA/SME Y14.5-1994.

●	FTI/ FUNCTION CRITICAL CHARACTERISTICS
<S>	SAFETY/ COMPLIANCE CRITICAL CHARACTERISTICS SYMBOL
CPK	DENOTES CPK DIMENSIONS MINIMUM CPK VALUE
(ST)	DENOTES A CHARACTERISTIC THAT PROVIDES AN INDICATION OF PROCESS PERFORMANCE PROCEDURE FOR MEASUREMENT AND TRACKING TO BE DEFINED IN LITTELFUSE INSPECTION INSTRUCTIONS
CP	DENOTES CP DIMENSIONS. -MINIMUM CP VALUE MUST BE WITHIN THE DIMENSIONAL LIMITATIONS SHOWN ON DRAWING AND INITIALLY LOCATED TO ALLOW FOR MAXIMUM TOOL LIFE

NAME	DATE
DRAWN B. WU	OCT/20/2021
CHECKED J. LI	OCT/20/2021
Expertise Applied Answers Delivered	
FORM NO. CVP-PE40-0005 REV B THIRD ANGLE PROJECTION	
TITLE DCNL 50A 48V CONTACTOR	
	SIZE C DWG. NO. OUTLINE OL-DCNLM50NB, CHT REV. A
DO NOT SCALE DRAWING	SCALE 2:1