

REVISIONS				
REV.	DESCRIPTION	DATE	DESIGNED	APPROVED
A	First issue of outline drawing	07-Jul-20	L.Dal Molin	M.Tinto

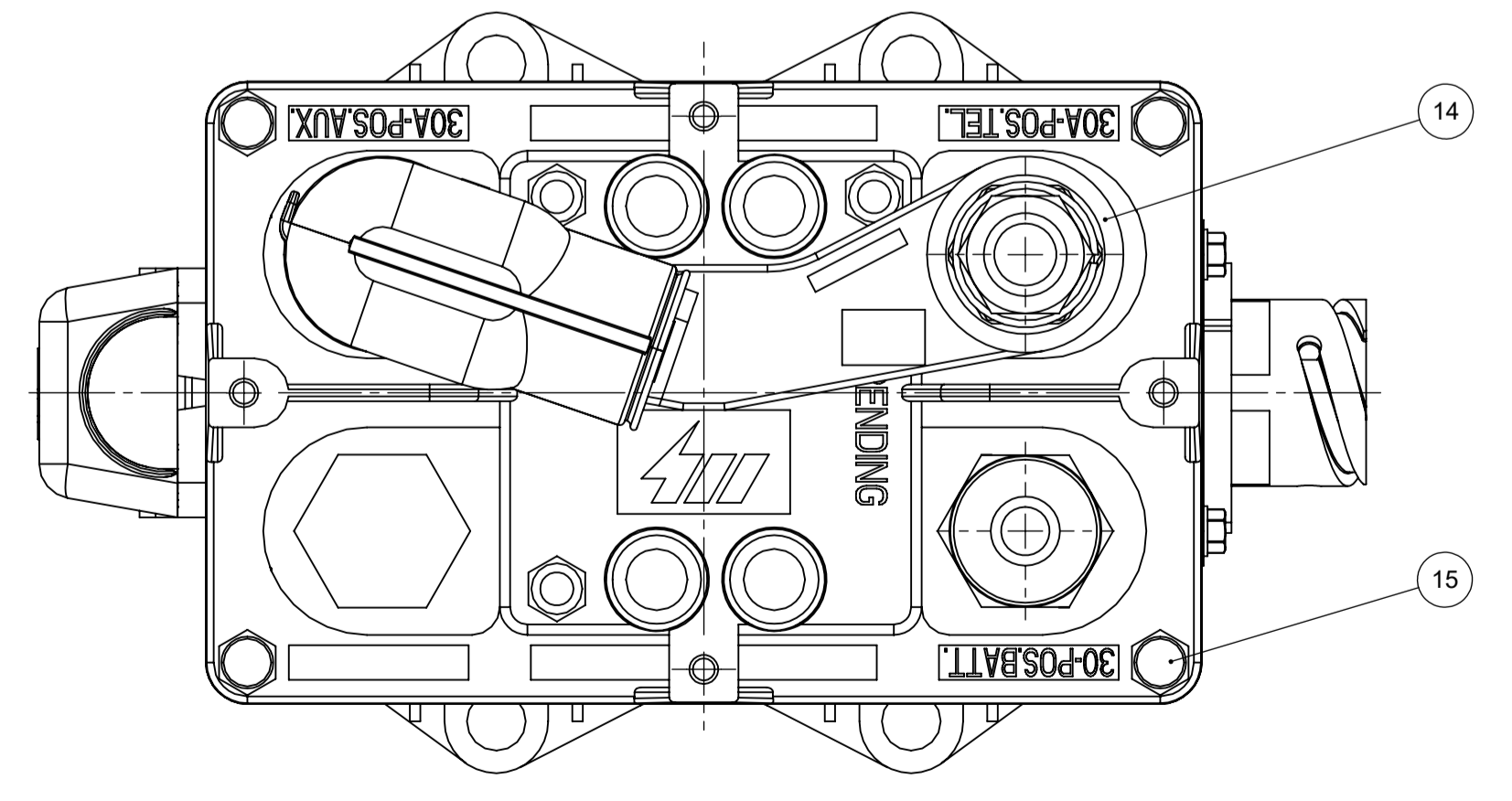

Electrical diagram

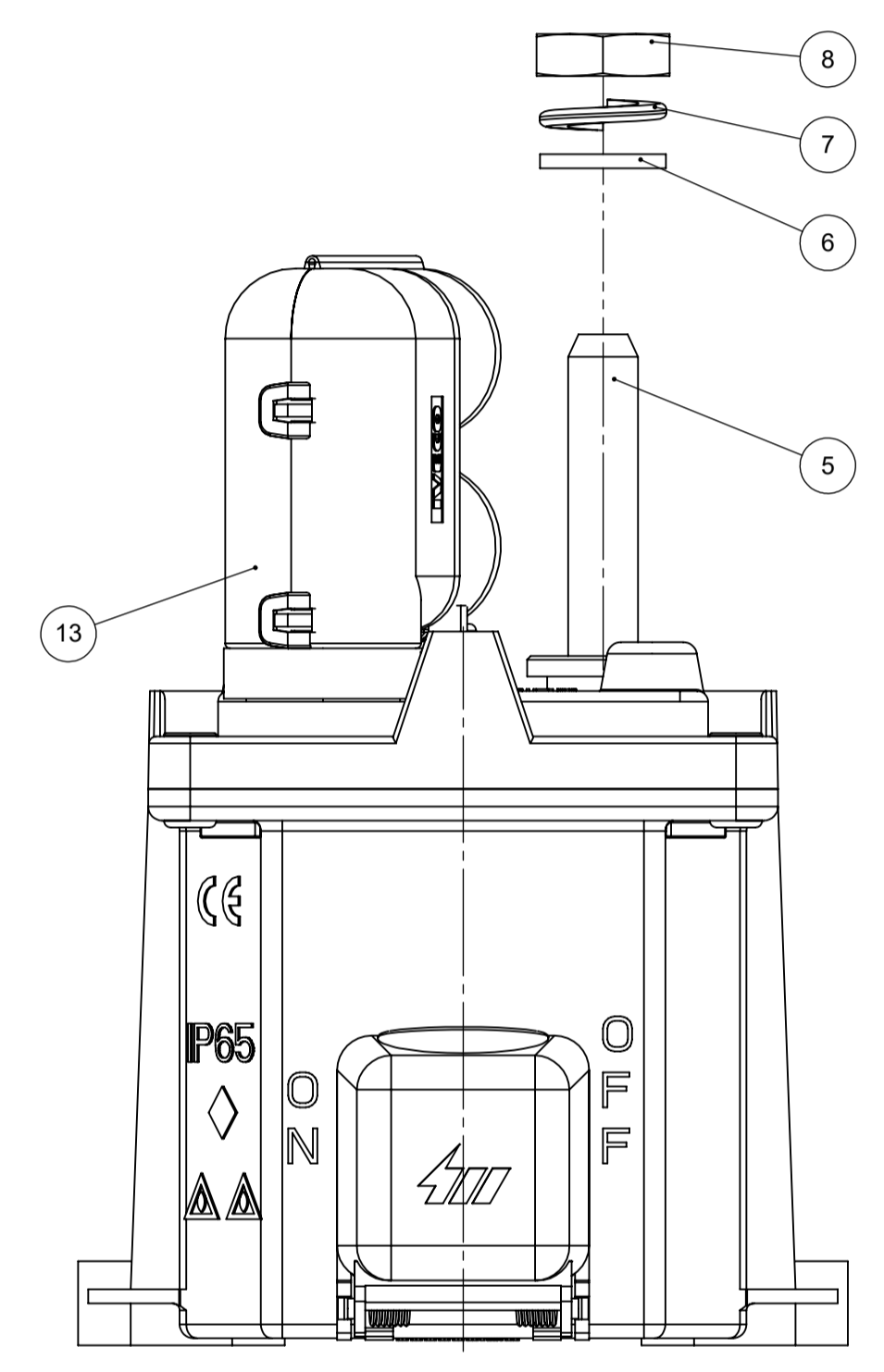
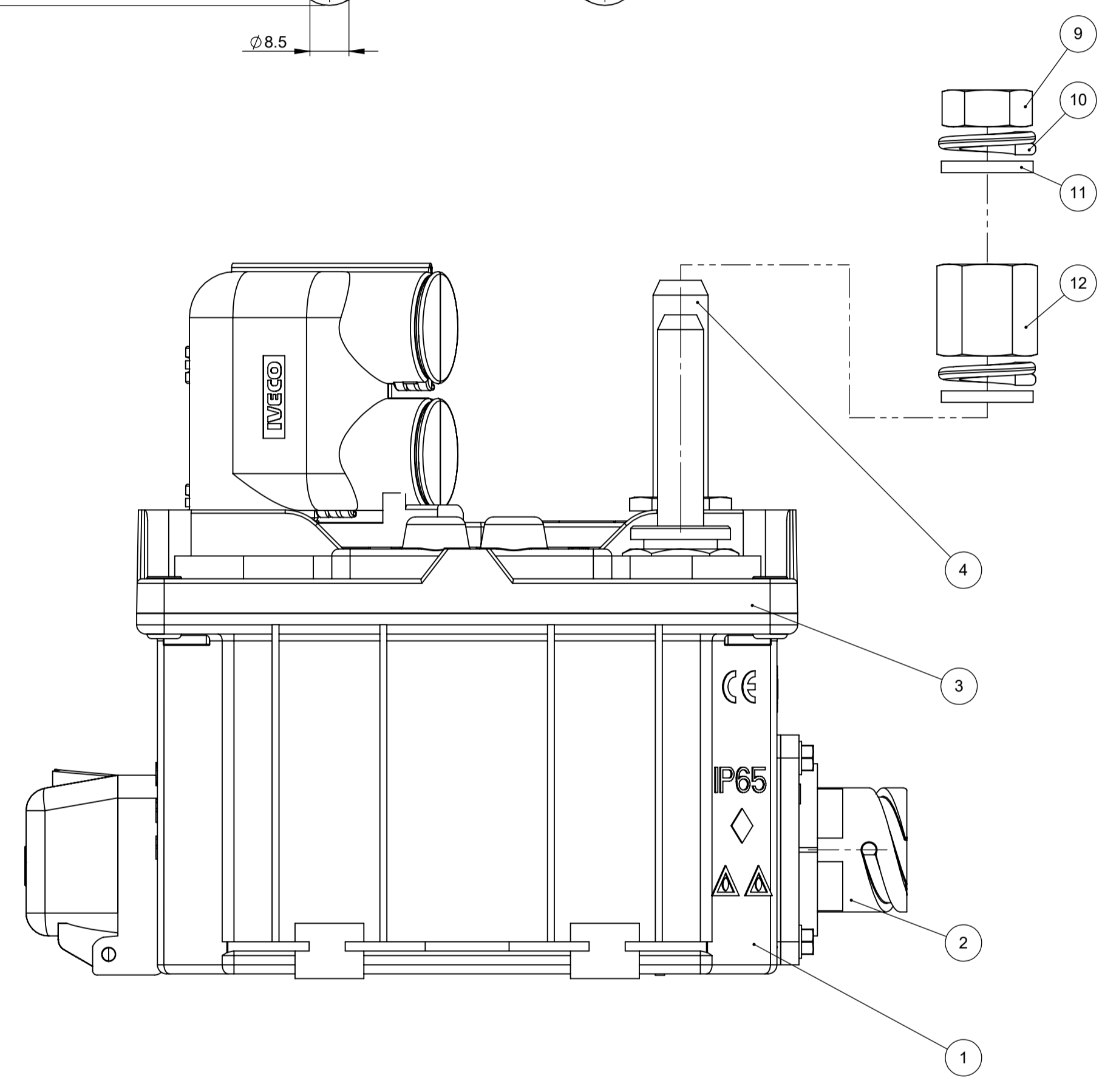
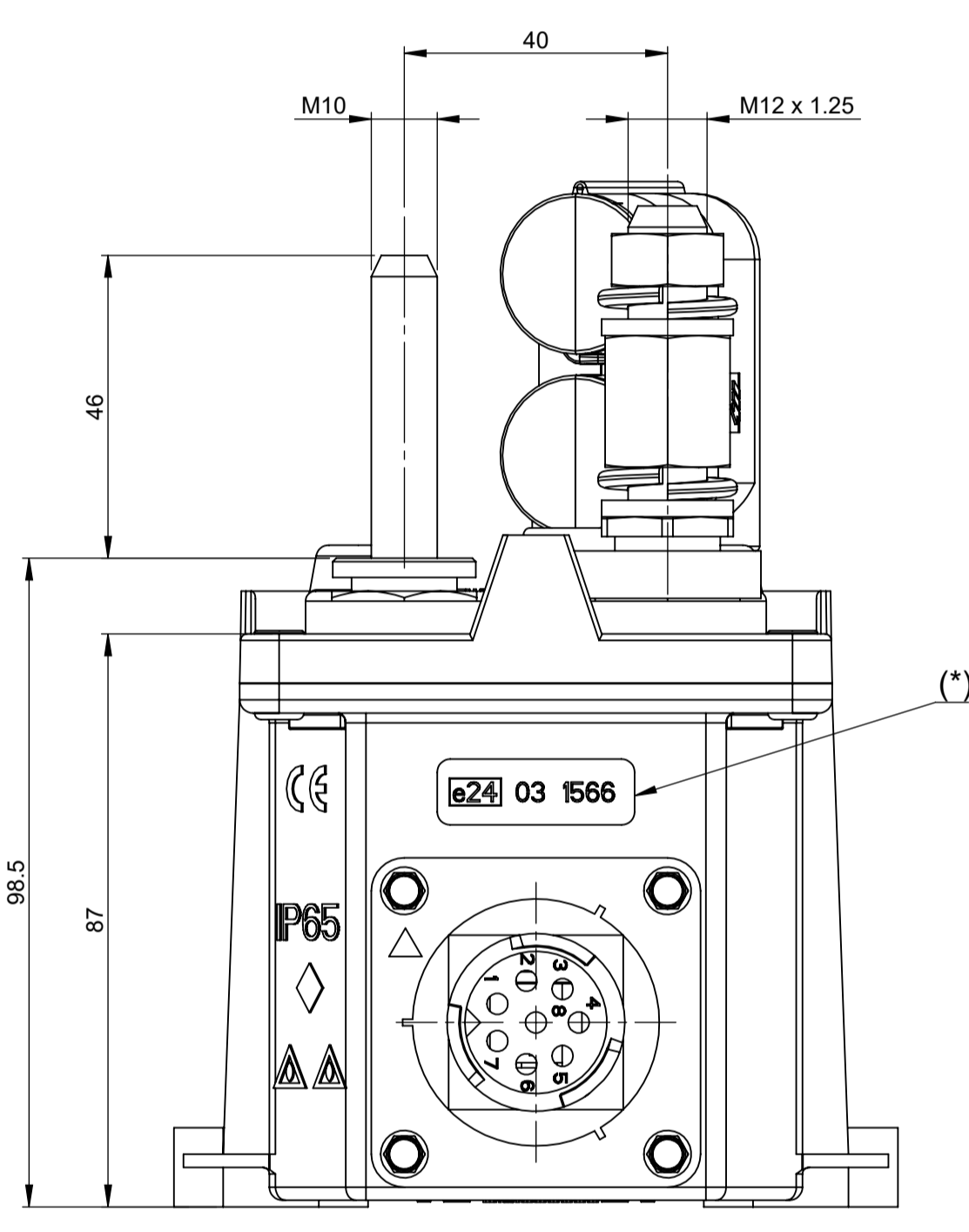
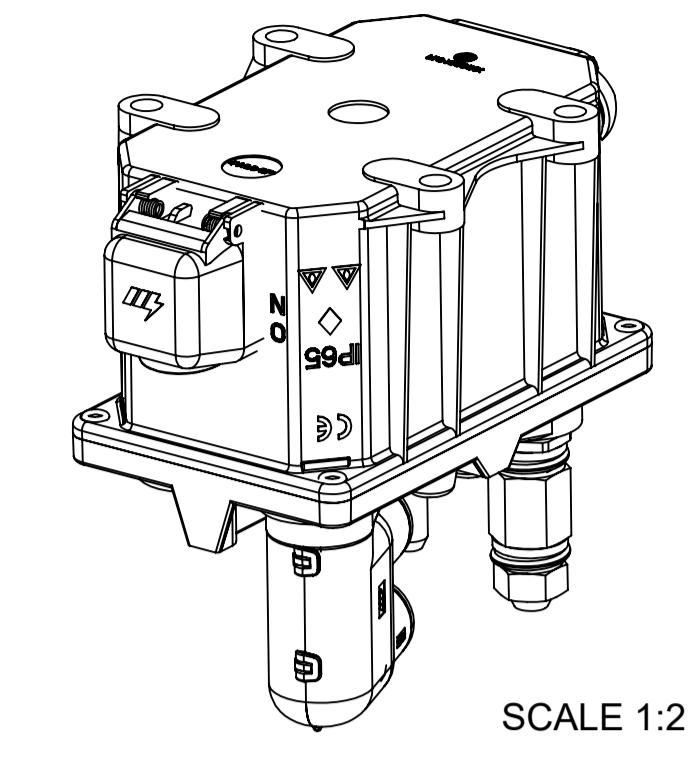
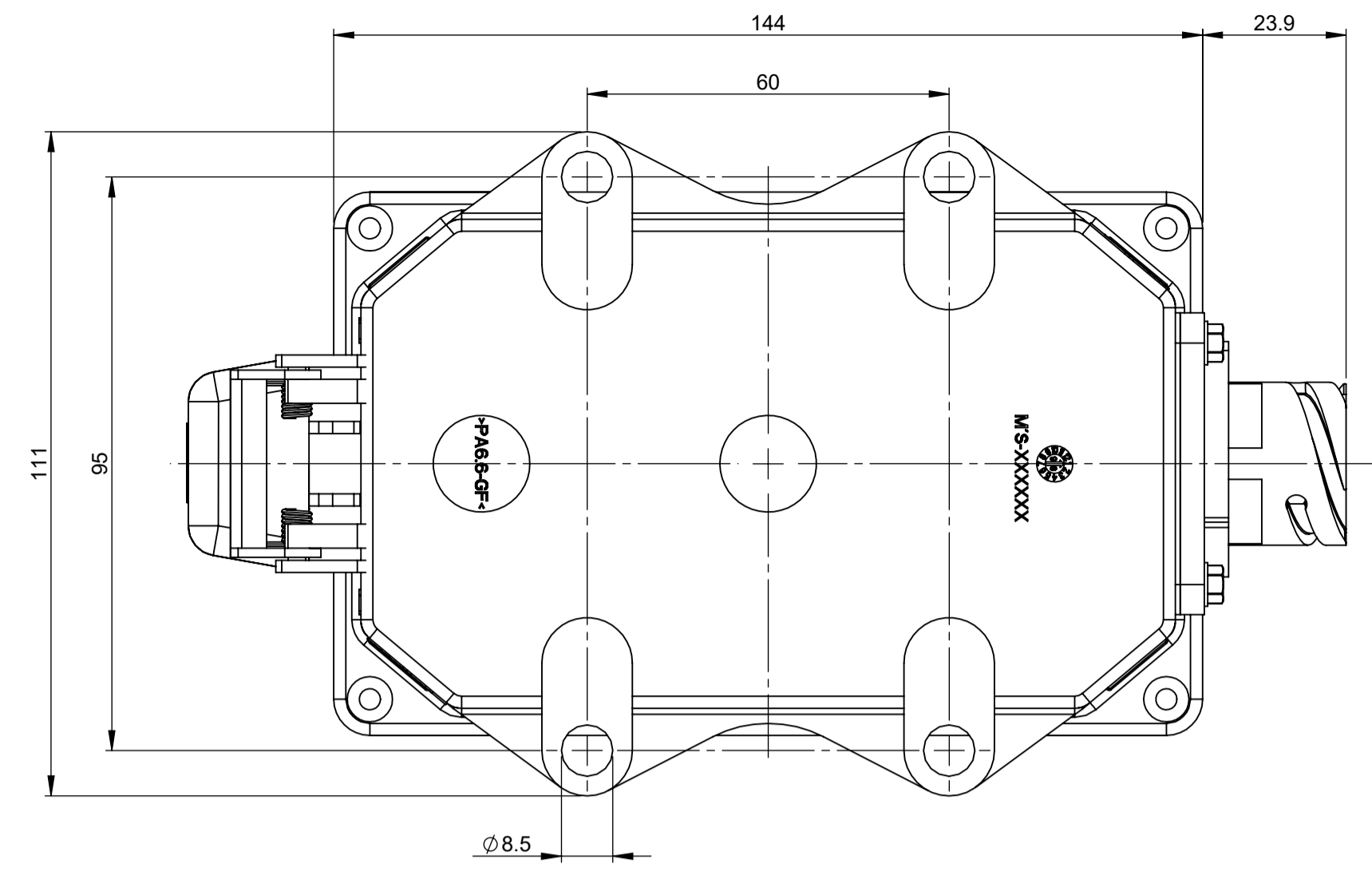
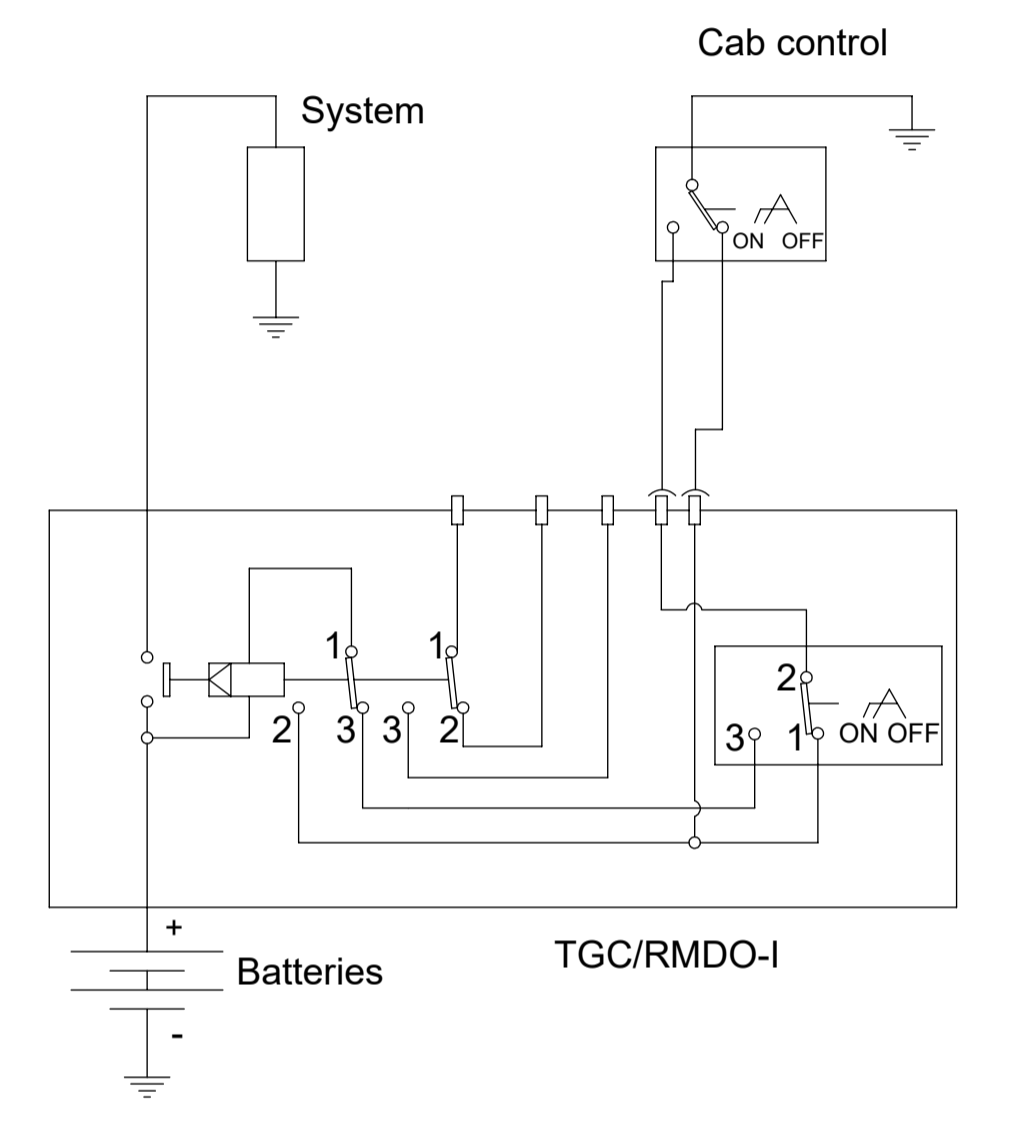

POS.	P/N	DESCRIPTION	MATERIAL	Q.TY	U/M
15		Closing rivets	Steel	4	EA
14		External bridge		1	EA
13	00226360	1 NW22 + 1 NW13 open	PA66//PB	1	EA
13	00226700	1 NW22 + 1 NW13 closed	PA66//PB	1	EA
13	00226660	2 closed protection NW 17	PA66//PB	1	EA
12		Nut M12x1.25x20	Brass	1	EA
11		Plane washer 12.3x20x2.5	Brass	2	EA
10		Spring washer Ø 12	Bronze	2	EA
9		Nut M12x25x6	Brass	1	EA
8		Nut M10	Brass	1	EA
7		Spring washer Ø 10	Bronze	1	EA
6		Plane washer 10.3x18x2	Brass	1	EA
5		Screw M10	Brass	1	EA
4		Screw M12x1.25 long	Brass	1	EA
3		Top cover	Thermosetting	1	EA
2		6-way male connector	PA6	1	EA
1		Box	PA66	1	EA

PRESCRIPTIONS

- The main switch must bear the name or code of the supplier, the code and the nominal voltage of the device, date of manufacture
- Tightening torque nut: 22 ± 1 Nm
- Tightening torque nuts M12x1.25: 22 ± 1 Nm
- Test the device according to IVECO Standard
- It is recommended to fix the device to the structure using M8 screws UNI 5931/1984 and plane washer 5.4x17 UNI 5592/1969 with a tightening torque 10 ± 2 Nm
- The device must bear the marking for the recycling of plastic materials

CHARACTERISTICS

- Nominal tension: 24 V
- Max continuous current main contacts: 250 A at 23°C
- Max short duration current main contacts: 2000 A at 23°C for 30 sec.
- Number of electrical and mechanical operations: 50.000

(*): provided in the kit

SAP drawing number:

Material and treatments:

DIMENSIONS AND TOLERANCES IN MILLIMETERS, DEFINED ACCORDING TO ISO 1101-2017.

linear dimensions						
0,5	>3	>6	>30	>120	>400	>1000
±0,2	±0,3	±0,5	±0,8	±1,2	±2	±3

angle (for range of lengths)

up to	>10	>30	>120	>400
±1°30'	±1°	±0°30'	±0°15'	

(●) FIT FUNCTION CRITICAL CHARACTERISTICS SYMBOL
 <S> SAFETY COMPLIANCE CRITICAL CHARACTERISTICS SYMBOL
 CPK DENOTES CPK DIMENSIONS MINIMUM CPK VALUE
 (ST) DENOTES A CHARACTERISTIC THAT PROVIDES AN INDICATION OF PROCESS PERFORMANCE PROCEDURE FOR MEASUREMENT AND TRACKING TO BE DEFINED IN LITTELFUSE INSPECTION INSTRUCTIONS
 CP DENOTES CP DIMENSIONS - MINIMUM CP VALUE MUST BE WITHIN THE DIMENSIONAL LIMITATIONS SHOWN ON DRAWING AND INITIALLY LOCATED TO ALLOW FOR MAXIMUM TOOL LIFE

NAME	DATE
DRAWN L. Dal Molin	28 May 19
CHECKED	

Littelfuse
 Expertise Applied Answers Delivered

FORM NO. CP-RES-2013 REV. A
 FIRST ANGLE PROJECTION
 TITLE: ELECTRICAL MAIN SWITCH
 TGC/RMDO-I 24V POS. ADR
 SIZE: A1
 SCALE: 1:1
 DO NOT SCALE DRAWING
 SHEET 1 OF 1