

PART NUMBER	"A"	"B"	LEAD "A" COLOR	LEAD "B" COLOR
MAHC0001ZXJ	127.0 ±5.0	127.0 ±5.0	BLACK	BLACK
MAHC0001ZXJA	127.0 ±5.0	127.0 ±5.0	RED	RED
MAHC0001ZXJB	150.0 ±5.0	150.0 ±5.0	BLACK	BLACK

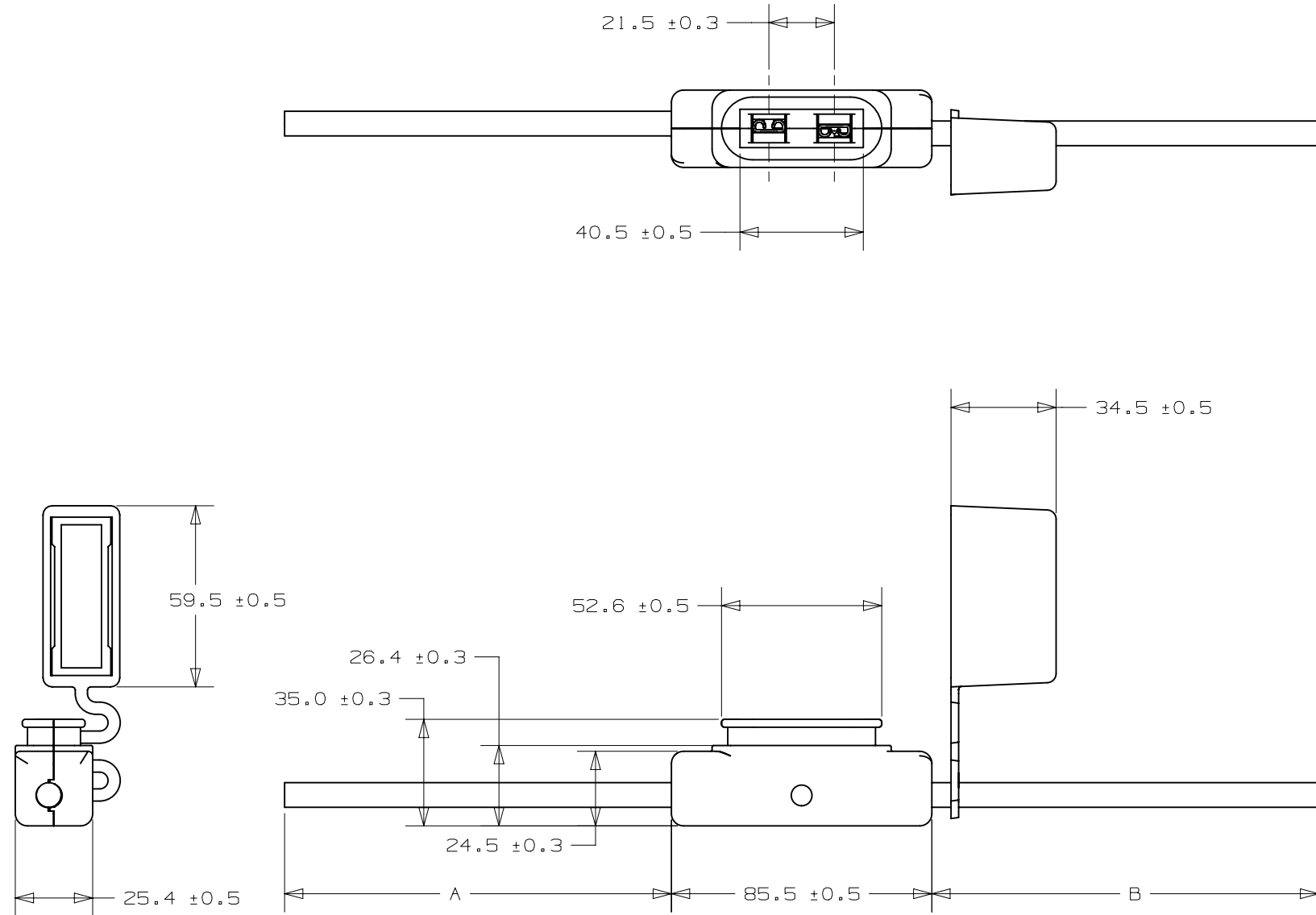

GENERAL NOTES:

- COVER TETHER IS SLID ON EITHER WIRE LEAD, UP TO THE BODY.
- FUSEHOLDER IS SHIPPED WITH COVER SNAPPED ONTO BODY.
- RATING: MAX. 60A, 32 VDC AT A MAX. OPERATING TEMP OF 80°C.
- INSULATING BODY: BLACK/PC
- INSULATING COVER: BLACK/TPV
- WIRE: 6AWG, UL 3288, 150°C RATED

**METRIC**  
ASSEMBLY

UNLESS OTHERWISE SPECIFIED, DIMENSIONS ARE IN MILLIMETERS. DIMENSIONS IN BRACKETS [ ] ARE INCHES

UNLESS OTHERWISE SPECIFIED, DIMENSIONS DO NOT INCLUDE PLATING.

⊙ DENOTES CRITICAL CHARACTERISTICS.

CPK DENOTES CPK DIMENSIONS, -MINIMUM CPK VALUE

ST DENOTES A CHARACTERISTIC THAT PROVIDES AN INDICATION OF PROCESS PERFORMANCE. PROCEDURE FOR MEASUREMENT AND TRACKING TO BE DEFINED IN LITTELFUSE INSPECTION INSTRUCTIONS

CP DENOTES CP DIMENSIONS, -MINIMUM CP VALUE MUST BE WITHIN THE DIMENSIONAL LIMITATIONS SHOWN ON DRAWING AND INITIALLY LOCATED TO ALLOW FOR MAXIMUM TOOL LIFE

NO	COMPONENT NO	DESCRIPTION	QTY/M	U/M
BILL OF MATERIAL				

LTR	DATE	REVISION	CHK	APD
A	09/16/14	511021ERA-NEW RELEASE FYUE		
B	06/12/15	5114396CA-NEW RELEASE MAHC0001ZXJA FYUE		
C	22/Jan/19	520277GCC-NEW RELEASE MAHC0001ZXJB FYUE		

COPIES TO	1	9	18
	2	10	19
	3	12	20
	4	13	21
	5	14	23
	6	15	33
	7	16	43
	8	17	53

MATL SPEC	
FINISH	
DRW DATE	09/16/14
FYUE	
CHK DATE	
APPD DATE	
SCALE	1:2
SUPER DR	
FINISH GOOD WT	
GRAMS/PIECE	

TOLERANCES UNLESS OTHERWISE SPECIFIED (REF. ISO 2768-mk)	UP TO 0.5	UP TO 3	UP TO 6	UP TO 30	UP TO 120	UP TO 400
DIMENSION	±0.1	±0.1	±0.1	±0.2	±0.3	±0.5
TOLERANCE						

3RD ANGLE PROJECTION

TITLE: HOLDER, MAXI INLINE WITH COVER

REVISION: C

DRWG. NO.: MAHC0001ZXJ

OUTLINE

Littelfuse  
DES. PLAINES, ILLINOIS 60016