

COVER "A" OPENING POSITION	COVER "B" OPENING POSITION	PREVAILING NUT LOCATION	TORQUE LOCATION (NOTE 3)	"NO TORQUE" LOCATION (NOTE 5)
C F	B D E	1 2 3	3	1 2

LTR	DATE	REVISION	CHK	APD
A	06/27/05	61752 - RELEASE D.GLAB		
B	07/28/05	844500-RENUMBER AND REVISE NOTES 2-6, ADD NOTE 5, ADD (2) NUTS TO TOP VIEW, REVISE CHART MTS		
C	09/22/05	84539B-REMOVED PREVAILING FEATURE FROM (3) NUTS, REVISE NOTES 2-6 DJG		
D	04/02/07	85414D-REDRAWN IN UG GMB		
E	08/31/07	000170EC/C - REMOVE USA FROM COVER BRK		
F	04/24/08	000463EC/D-CHG, NOTE 3 GMB		

BOLD NUMBER DESIGNATION REFERS TO NUT & TORQUE LOCATION (SEE CHART)

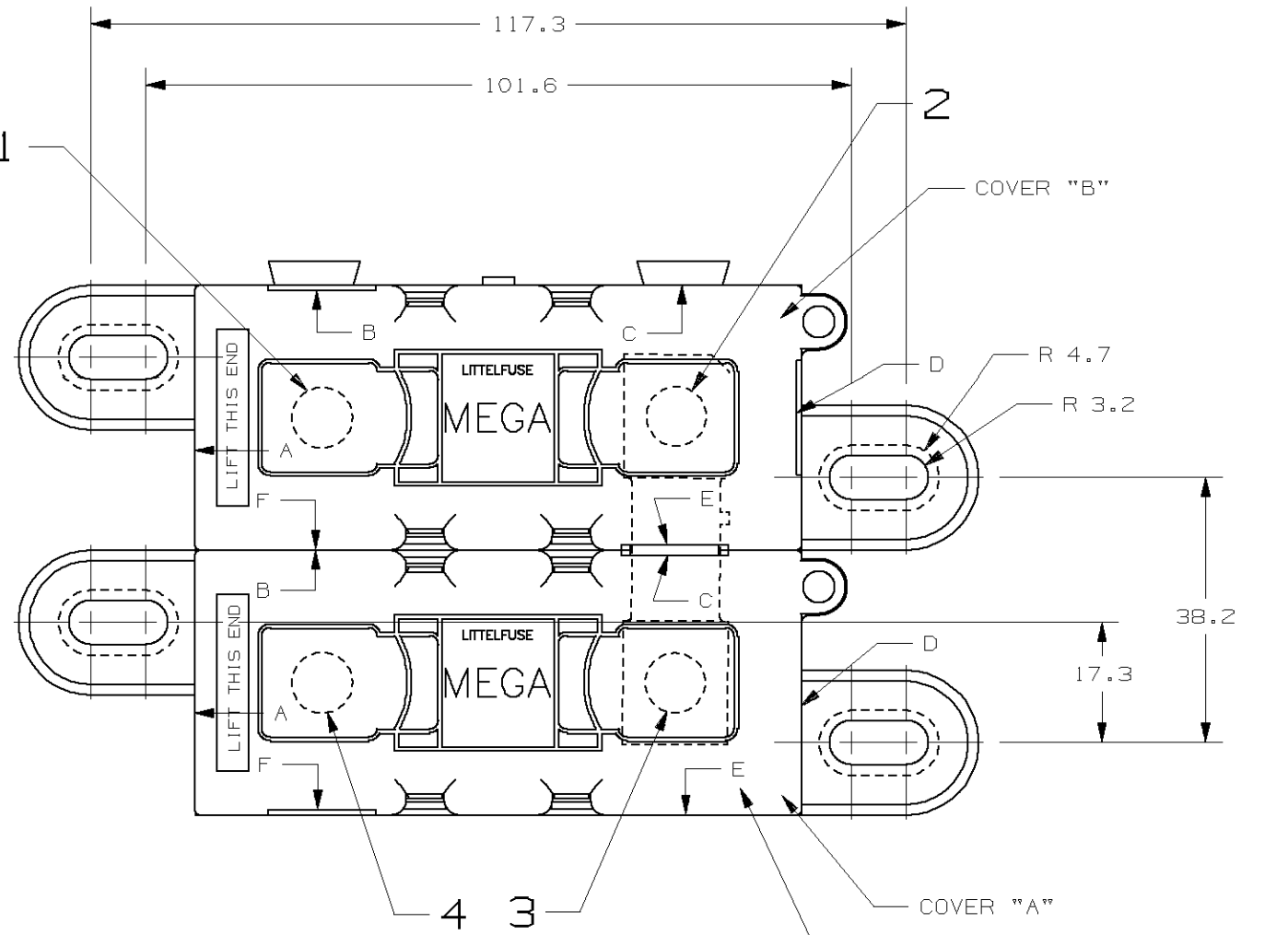

LETTER DESIGNATIONS REFER TO POSITIONS OF AVAILABLE COVER OPENINGS. (SEE CHART)

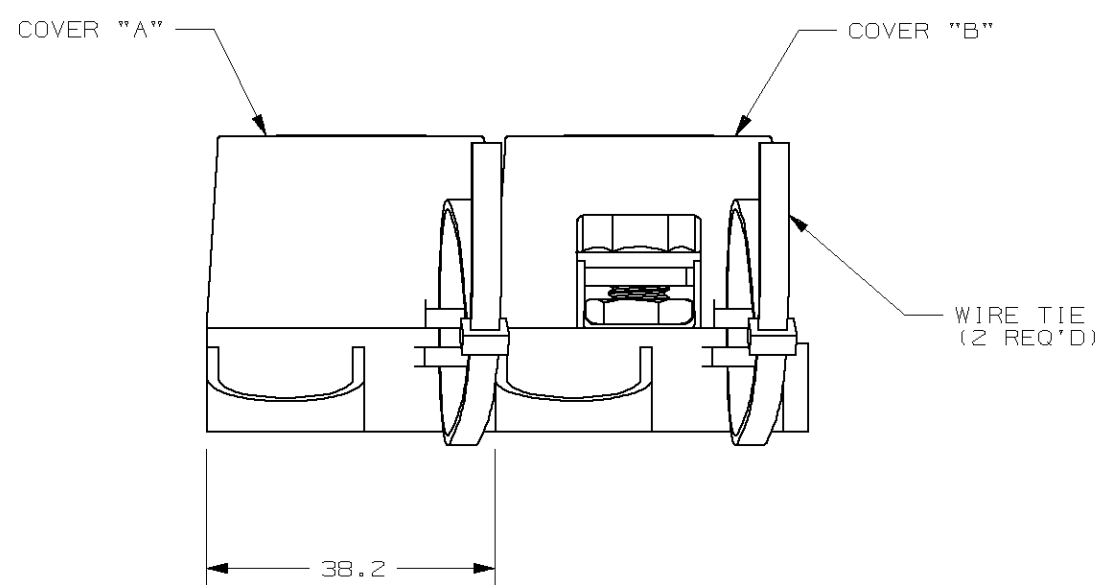
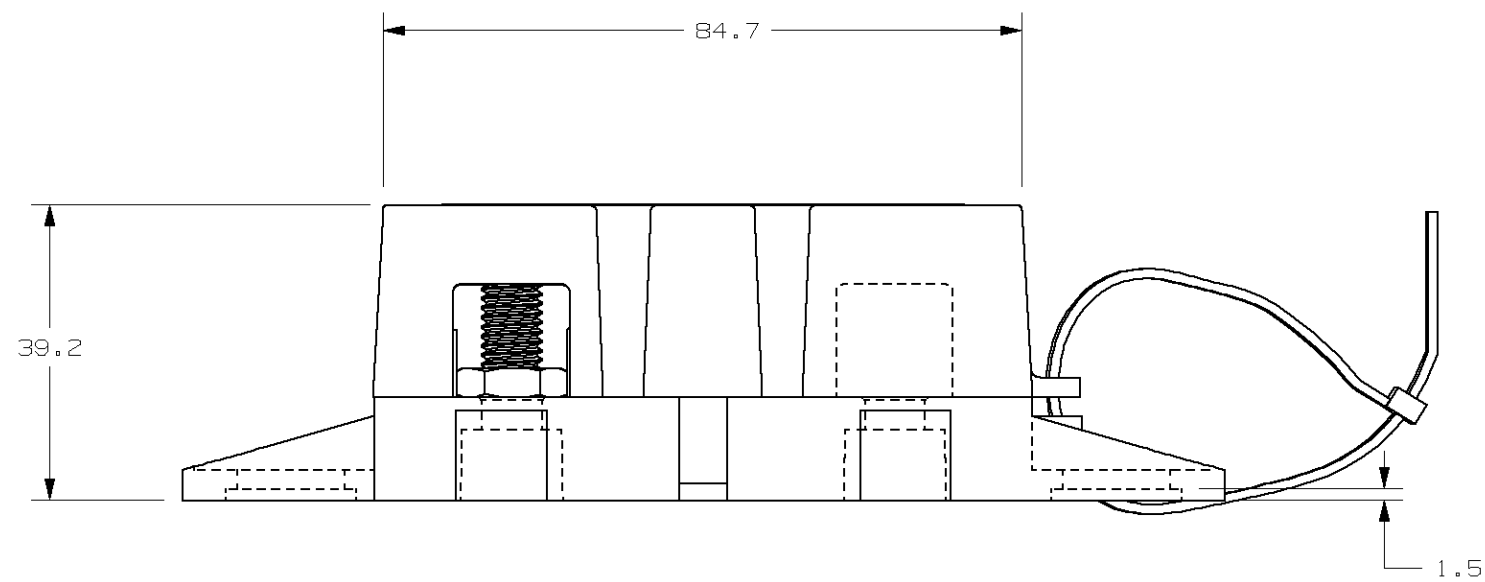
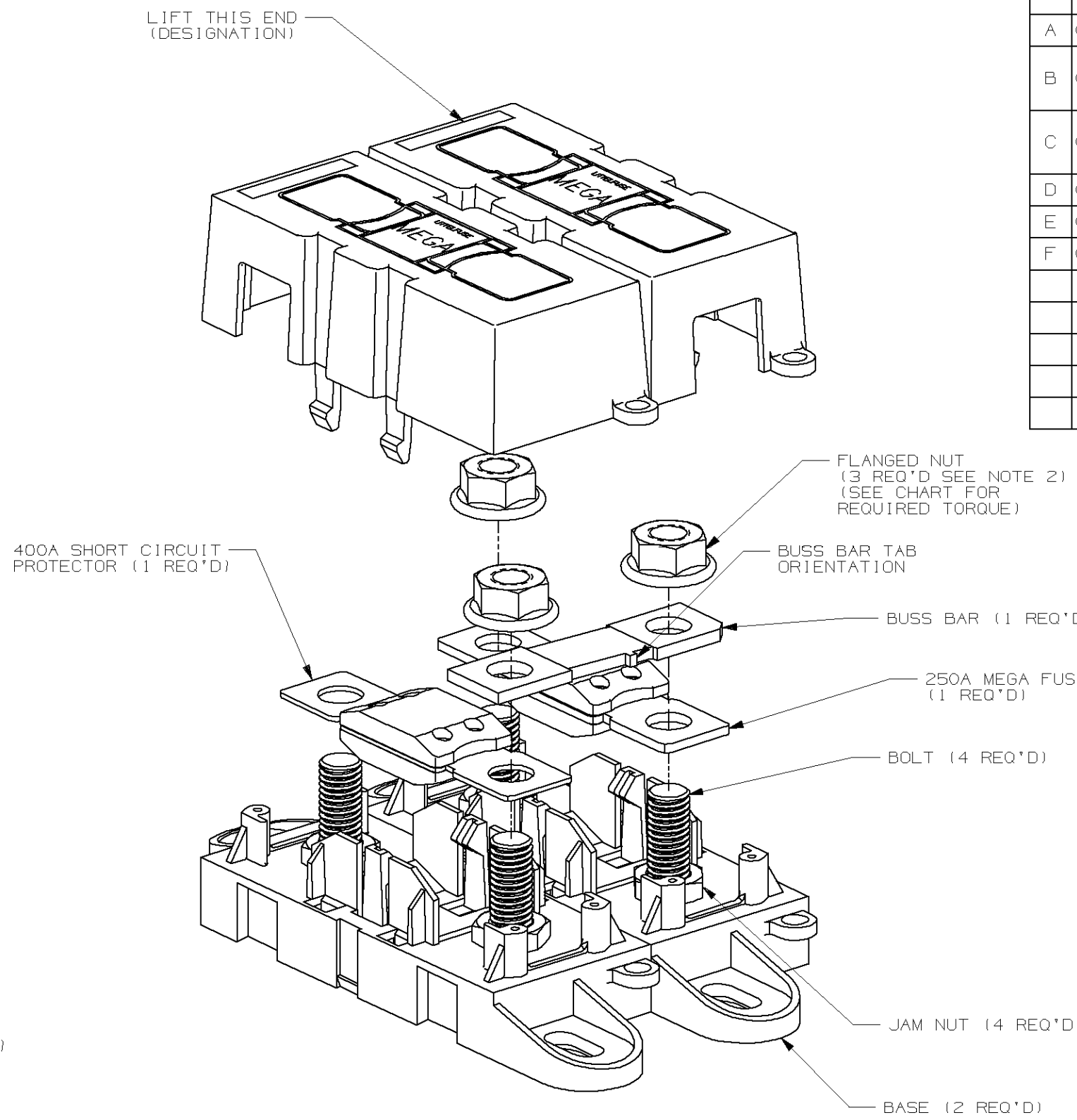

GENERAL NOTES:

- COVER RETENTION TEST: MINIMUM FORCE OF 2 LBS. IS REQUIRED TO REMOVE COVER WHEN IT IS SUSPENDED UPSIDE DOWN. FORCE SHALL BE APPLIED THROUGH THE INNER HOLES (2) IN BASE. USE FIXTURE #T-C403 TO SUPPORT PART.
- FLANGED NUT TO MEET THE FOLLOWING CRITERIA: FORD PART NO. W520413 FINISH: S437.
- TORQUE APPLIED AS INDICATED IN CHART TORQUE REQUIREMENTS FOR THE HEX NUT USED TO SECURE THE BUSSBAR OR THE CUSTOMER RING TERMINAL TO THE MEGA FUSE TO BE:
8mm NUT - 12-18 NEWTON METERS [106-159 IN-LBS]
- L/F VALIDATION TEST SPEC. VS-005005.
- MANUALLY ASSEMBLE FLANGED NUT ONTO STUD AND FINGER TIGHTEN ANYWHERE BELOW TOP OF STUD, FOR ALL "NO TORQUE" LOCATIONS

6. MATERIALS:

- * BODY - GLASS FILLED THERMOPLASTIC
COLOR - BLACK
- * COVER - THERMOPLASTIC
COLOR - BLACK
- * WIRE TIE - THERMOPLASTIC
COLOR - BLACK
- * STUDS & NUTS - M8 X 1.25 STEEL
ZINC PLATE WITH TRIVALENT CHROMATE, LEACHED AND SEALED,
INTEGRAL TORQUE CONTROL LUBRICANT FINISH
(MEETS 96 HR. ASTM STD. B-117 SALT SPRAY REQ.)

NO	COMPONENT NO	DESCRIPTION	QTY/M	U/M
-				
-				
-				

BILL OF MATERIAL

UNLESS OTHERWISE SPECIFIED, DIMENSIONS ARE IN MILLIMETERS. DIMENSIONS IN BRACKETS [] ARE INCHES

UNLESS OTHERWISE SPECIFIED, DIMENSIONS DO NOT INCLUDE PLATING.

⊙	DENOTES CRITICAL CHARACTERISTICS.
CPK	DENOTES CPK DIMENSIONS. -MINIMUM CPK VALUE
ST	DENOTES A CHARACTERISTIC THAT PROVIDES AN INDICATION OF PROCESS PERFORMANCE. PROCEDURE FOR MEASUREMENT AND TRACKING TO BE DEFINED IN LITTELFUSE INSPECTION INSTRUCTIONS
CP	DENOTES CP DIMENSIONS. -MINIMUM CP VALUE MUST BE WITHIN THE DIMENSIONAL LIMITATIONS SHOWN ON DRAWING AND INITIALLY LOCATED TO ALLOW FOR MAXIMUM TOOL LIFE

COPIES TO	MATL SPEC
1 9 18	FINISH
2 10 19	
3 12 20	
4 13 21	DRW GLAB DATE 06/27/05 SCALE 1:1
5 14 23	CHK DATE SUPER DR
6 15 33	APPD DATE FINSH GOOD WT
7 16 43	
8 17 53	

ONE PLACE DEC +/- .3	THREE PLACE DEC +/- .100
TWO PLACE DEC +/- .25	ANGULAR +/- 1°

TITLE	DUAL MEGAFUSE HOLDER FOR 400A & 250A
-------	--------------------------------------

REVISION	DRWG. NO.	OUTLINE
F	02982008ZXT	

METRIC

Littelfuse
DES PLAINES, ILLINOIS 60016

CAD GENERATED DRAWING - NO PENCIL CHANGES ALLOWED