

## Application Hints for Transient Voltage Suppression Diode Circuits

Littelfuse.com

### Introduction

Transient Voltage Suppression (TVS) diodes provide a simple solution to increase the EMI and ESD immunity level of a circuit and only a few guidelines must be followed to provide effective surge protection. This document will analyze several important application features of avalanche TVS and diode arrays. In addition, examples will be provided to demonstrate the advantages and disadvantages of uni and bidirectional TVS devices. The following circuit design considerations will be analyzed:

- Internal IC versus External TVS Protection Circuits
- TVS Diode Turn-on Voltage
- Diode Array Application Hints
- Common Mode Offset Voltages
- Back Drive Protection
- Differential Input and Output Application Guidelines

### Internal IC versus External TVS Protection Circuits

Transient Voltage Suppression (TVS) diodes can be used to supplement the surge immunity level of an IC. Most ICs contain internal protection circuits that function well at preventing ESD failures that occur in assembly; however, they are often inadequate for protecting against surge events that occur in normal product usage. The surge ability of a silicon TVS diode is directly related to its size and external

### APPLICATION NOTE

devices are typically a factor of at least ten times larger than the internal IC TVS devices. External TVS diodes provide a higher level of surge protection because it is typically not practical for an IC to incorporate large protection devices. In addition, the internal protection circuit of most ICs is designed to handle only a few ESD events while an external TVS device provides immunity for an indefinite amount of surges.

Knowledge of the IC's internal surge protection circuit can be helpful in selecting an external TVS device with an appropriate power rating and turn-on voltage. Unfortunately, the data sheets of most ICs provide only an ESD rating and do not disclose the internal protection circuit. Internal IC protection circuits can be created using high voltage transistors, Zener diodes, diode arrays, thyristors and overvoltage detection switches. Figure 1 provides two popular IC circuits used to provide internal surge protection. Guidelines to ensure that a surge event will not exceed the power rating of the internal protection circuit will be shown in the following sections.

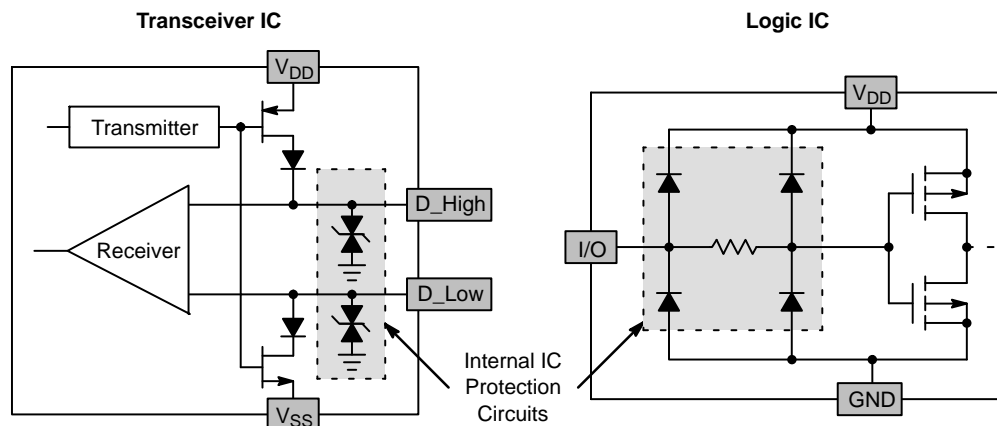

**Figure 1. Zener Diodes are a Popular Choice for the Internal Protection Circuit of a Transceiver IC that Requires Power Surge and ESD Protection. Diode Arrays are a Frequent Choice for the Internal ESD Protection Circuit of a Logic IC**

**TVS Diode Array Turn-On Voltage**

The main function of an external TVS device is to limit the current through an IC by virtue of decreasing the magnitude of the surge voltage. An ideal external TVS device will turn-on before the IC's internal circuit and absorb the entire energy of the surge pulse. In practice both the external and internal protection circuits will usually turn-on during a surge event. The IC's reliability will not be impacted if the internal protection circuit current is limited to a low value. In addition, the location of the TVS devices is a key factor that determines whether the majority of the surge energy is absorbed by the external protection circuit. Reference [4] provides PCB layout guidelines that help to ensure that the surge protection will be provided by the external TVS devices rather than the IC's internal protection circuit.

Many ICs incorporate a diode array for ESD protection; thus, the internal and external protection circuits often have a similar topology, as shown in Figure 2. A value of 0.7 V and 0.3 V can be used to estimate the turn-on voltage of external switching and Schottky diodes, respectively. The turn-on voltage of the internal IC protection circuit is typically equal to 0.7 V for a bipolar process; however, the value for a CMOS device is a function of several process variables, as shown below by the voltage equation of a MOSFET diode.

$$V_{\text{MOSFET\_Diode}} = V_T + \sqrt{\frac{I_{DS}}{\frac{1}{2}\mu_o C_{ox} \left(\frac{W}{L}\right)}} \quad (\text{eq. 1})$$

Where:

- $V_T$  = Threshold Voltage
- $I_{DS}$  = Drain-to-Source Current
- $\mu_o$  = Electron Mobility
- $C_{ox}$  = Gate Oxide Capacitance Per Unit Area
- $W/L$  = Width and Length Dimensions

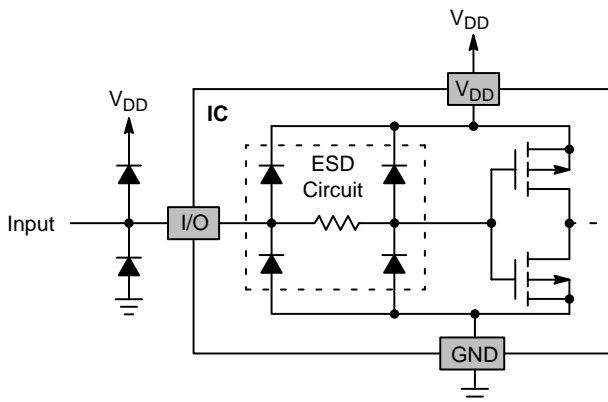

**Figure 2. An External Diode Array often has a Similar Topology to the IC's Internal ESD Protection Circuit; however, the Turn-on Voltages of the Two Arrays can be Different**

Often CMOS ICs are designed with MOSFET diodes that have a  $V_T$  greater than 0.7 V to increase their immunity against ground noise; thus, the external array will usually have a lower turn-on voltage. The  $V_T$  of a low voltage IC may be low enough that the turn-on of the MOSFETs can be lower than the 0.7 value of a standard diode. One solution to this problem is to use a Schottky diode array, as shown in Figure 3. Schottky diodes typically have a turn-on voltage of approximately 0.3 V.

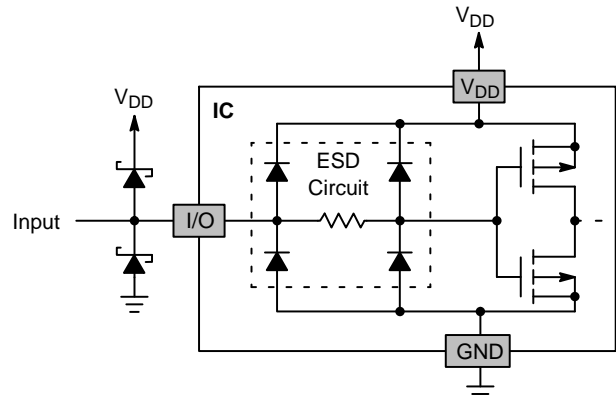

**Figure 3. The Low Turn-on Voltage of a Schottky Diode can be Used to Provide Surge Protection for Low Voltage ICs**

The circuit shown in Figure 4 is another alternative to solve the potential problem that can occur if the internal and external arrays have a similar turn-on voltage. The resistor that is located between the two arrays ensures that the majority of the surge energy will be dissipated by the external circuit. The IC's internal diodes also turn-on, but the current through these devices will be relatively low compared to the external diode current.

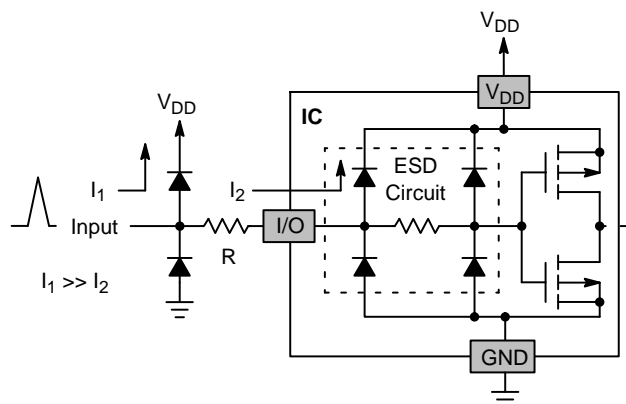

**Figure 4. R Forces  $I_1 \gg I_2$ , which Ensures that the Majority of the Surge Energy is Diverted by the External Diode Array rather than by the IC's Internal ESD Circuit**

**Diode Array Application Hints**

**Decoupling the Power Supply**

Diodes arrays steer the surge current into the power supply rails where the energy of the transient voltage pulse is dissipated, as shown in Figure 5. A positive surge pulse will

be clamped to a voltage that is equal to a forward diode voltage drop above the supply voltage ( $V_{DD}$ ). Typically the  $V_{SS}$  pin is grounded; thus, a negative pulse will be clamped to a voltage of one diode drop below ground.

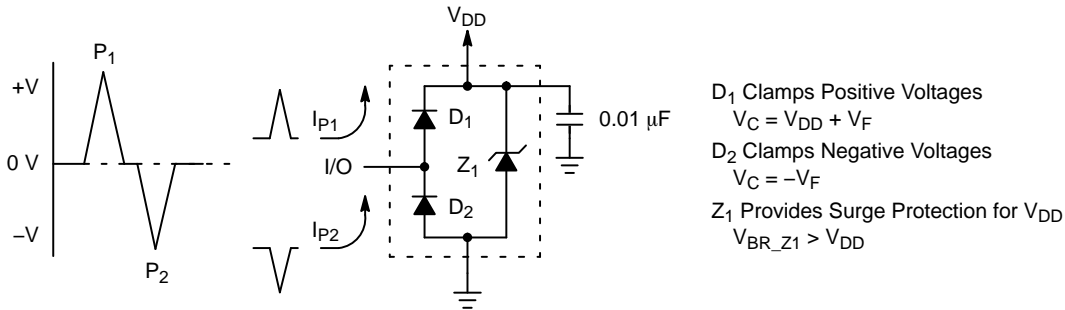

**Figure 5. Adding a Decoupling Capacitor and Avalanche TVS to a Diode Array Enhances the Ability to Clamp the Surge Voltage to a Diode Drop above or below the Power Rails**

Decoupling capacitors and avalanche diodes are two simple solutions to improve the load regulation of a power supply during a surge effect. Placing an RF ceramic capacitor of approximately 0.01 to 0.1  $\mu\text{F}$  across the power pins reduces the magnitude of the surge pulse. Additional surge protection can be provided by using a diode array with a built-in avalanche diode that has a breakdown voltage slightly higher than  $V_{DD}$ . Integrating the avalanche diode in the TVS IC minimizes the inductances associated with the device connections, which reduces the magnitude of the surge pulse due to the  $V = L (\Delta I/\Delta t)$  equation.

The diode array clamping equations assume that the power supply rails  $V_{DD}$  and  $V_{SS}$  are a constant voltage source. This is a good assumption for low frequency load changes, but may not be valid during the high frequency load demand of a surge pulse. For example, the IEC 61000-4-2 ESD pulse has a rise time of less than 1.0 ns and a peak current of 30 A. The high peak energy of the ESD pulse can

increase the power supply’s output impedance. The change in impedance produces a peak clamping voltage significantly larger in magnitude than what Figure 5’s equations predict. Reference [4] provides additional recommendations that can be used to maximize the clamping performance of the diode array.

**Diode Array Surge Ratings**

Careful interpretation of a diode array’s data sheet specifications is required because the surge rating is a function of the test configuration. Some diode arrays have a power rating that is measured with power applied to the  $V_{DD}$  pin, while others float the power pin during the surge test. This issue is especially important with Schottky diodes because the rating of an unpowered array is much lower than a powered array. The lower surge capability of an unpowered Schottky array is due to their relatively poor reverse bias rating compared to a standard diode.

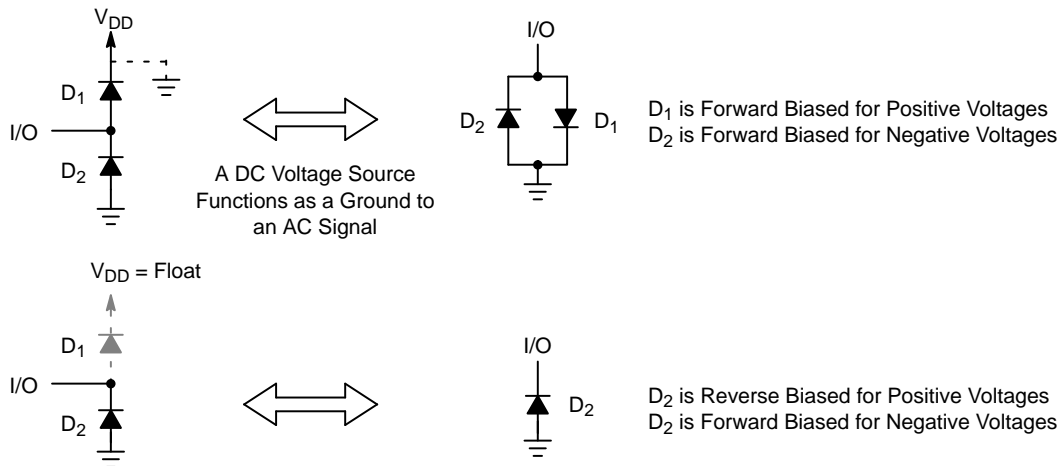
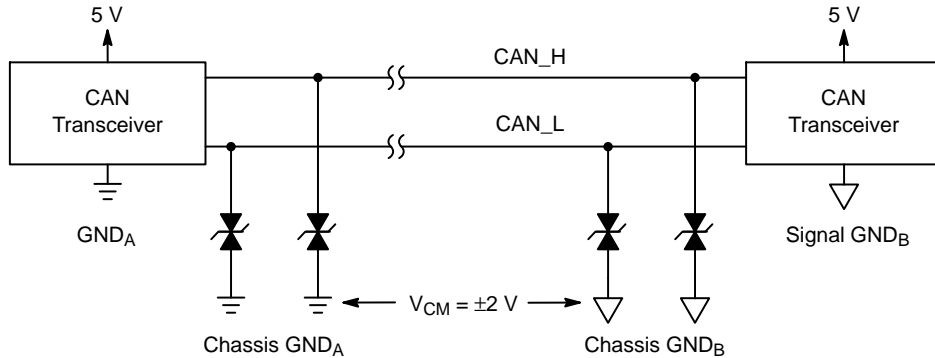

**Figure 6. The Power Pin ( $V_{DD}$ ) Functions as a Ground for High Frequency AC Signals. The Diodes will be Exposed to a Reverse Biased Voltage only if  $V_{DD}$  is Floating**

The reverse bias surge rating of a diode is typically not an issue if power is applied to the array. The reverse bias condition of diode  $D_2$  can only occur if the negative surge pulse is applied to the I/O pin while  $V_{DD}$  is in a high impedance or floating state. If the array is powered, the DC voltage source functions as a ground to the high frequency AC signal and the surge pulse will be effectively applied to two diodes that are in an anti-parallel configuration, as shown Figure 6. One of the diodes will be forward biased and this diode will have a turn-on voltage that is well below the maximum reverse biased voltage of the other diode.

**Common Mode Offset Problems**

The potential for a common mode offset problem exists in any system that uses a common ground system and has any remote modules that are connected through long cables. A common mode voltage is created when there is a significant difference in the voltage potential between the ground reference of the transmitting and receiving nodes. The common mode offset means that the voltage of the data lines can be offset by several volts above or below their nominal voltage levels.



**Figure 7. Bidirectional TVS Devices Solve the  $\pm 2.0$  V Common Mode Offset Voltage ( $V_{CM}$ ) Requirement of CAN Transceivers**

The Controller Area Network (CAN), shown in Figure 7, is an example of a system that has a common mode voltage specification. CAN is a popular serial communication network for automotive and industrial control applications. The CAN common mode voltage specification does not change the differential voltage between the data lines; however, the absolute value of the CAN\_H and CAN\_L

signals can vary by up to two volts, as shown in Figure 8. Bidirectional TVS devices should be used to ensure that the protection devices do not clamp if the data lines are offset within the specified common mode range. Unidirectional avalanche and diode arrays should only be used in systems where the difference in the voltage potential of the ground references is small.

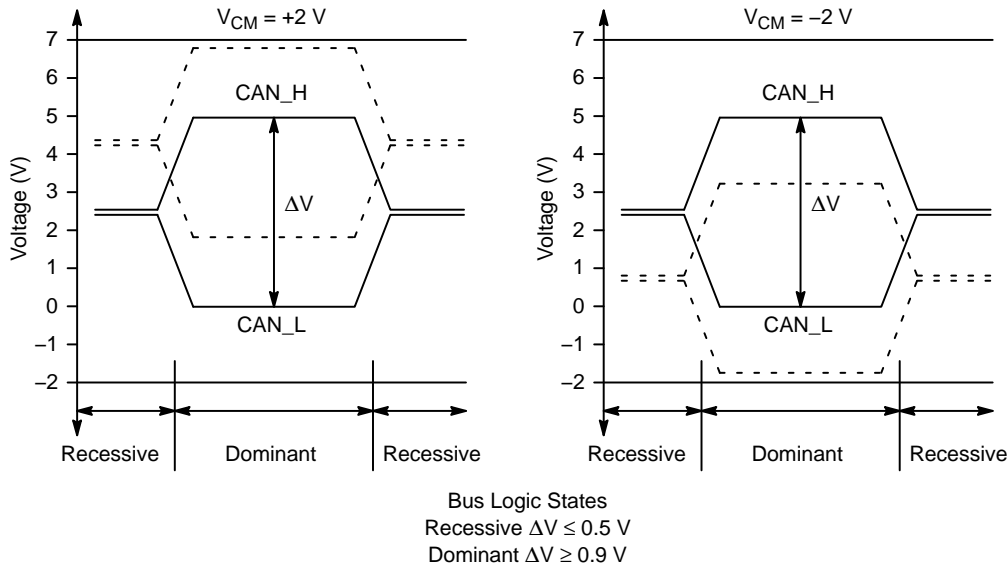

**Figure 8. CAN Data Lines have a Normal Voltage Range of 0 to +5.0 V; However, the Common Mode ( $V_{CM}$ ) Requirement can Shift the Level of the Signals by  $\pm 2.0$  V**

**Back Drive Protection**

Figure 9 illustrates the potential back drive problem that can exist with a diode array. Back drive occurs when a path exists for current to flow through the diode array via the data line. The data line connecting the two modules can unintentionally provide power to module 1 if  $V_{DD2}$  is greater than  $V_{DD1}$ . This condition can cause powerup problems with logic ICs and anomalies such as the illumination of indicator lights in module 1 when the unit is unpowered.

The back drive problem can be solved with the two protection circuits shown in Figures 10 and 11. Figure 10's circuit uses an avalanche TVS diode to eliminate the current

path between the two modules; however, the path will still exist if the module 1's IC contains an internal diode array. A second option to solve back drive, shown in Figure 11, can be implemented by adding an avalanche and blocking diode to the diode array. The avalanche diode is used to absorb the surge event, while the blocking diode serves to break the current path to  $V_{DD1}$ . Locating the external diode array close to the I/O connector helps to ensure that  $I_{PU2} < I_{PU1}$ . The lower impedance current path of  $I_{PU1}$  ensures that the majority of the energy of a surge event will be dissipated by the external diode array.

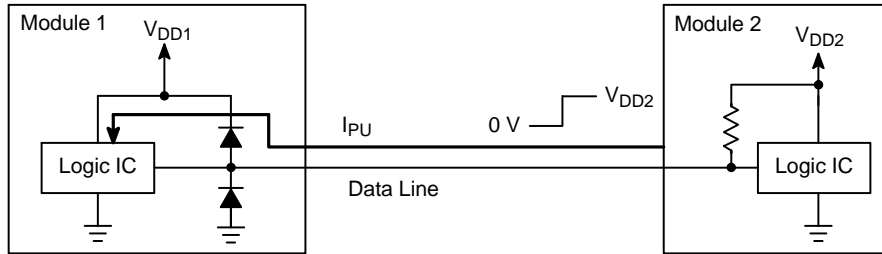

**Figure 9. A Diode Array Creates a Back Drive Current Path ( $I_{PU}$ ) to Provide Power through a Data Line when  $V_{DD2} > V_{DD1}$**

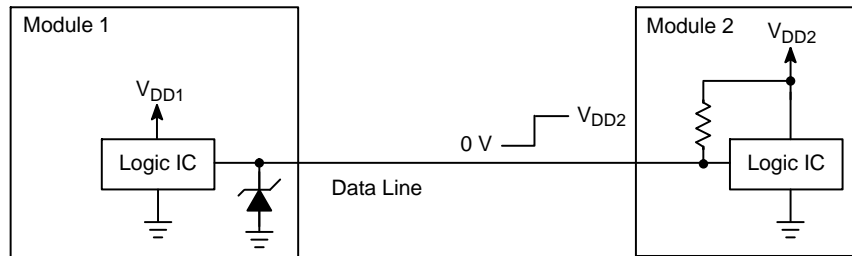

**Figure 10. A TVS Avalanche Diode Eliminates the Current Path ( $I_{PU}$ ) for Back Drive; However, the Problem will Still Exist if Module 1's Logic IC Uses a Diode Array for ESD Protection**

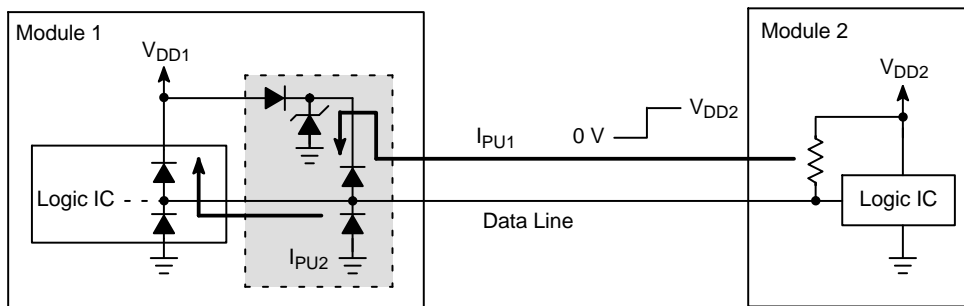
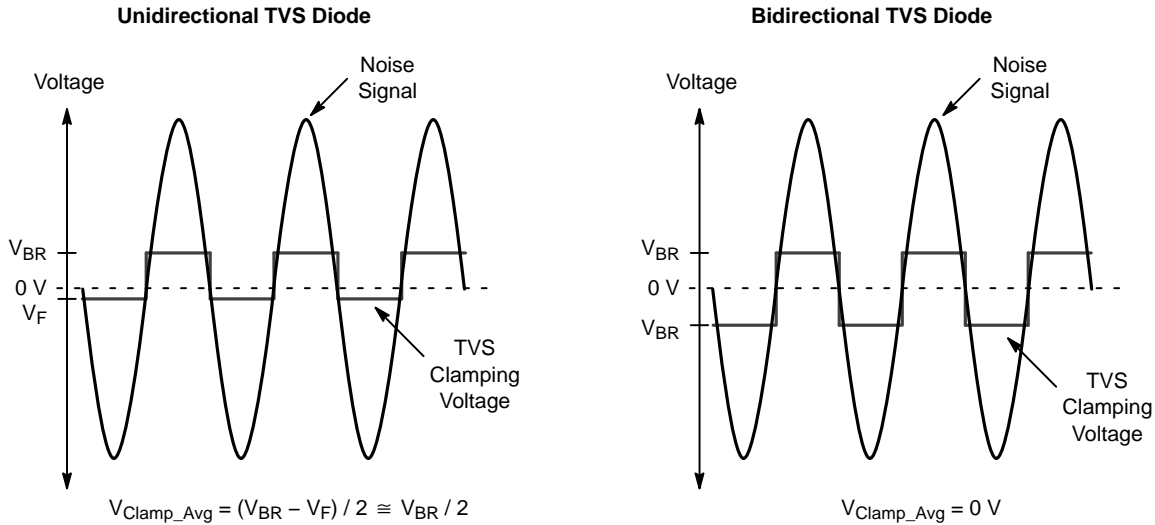

**Figure 11. Back Drive Protection can be Implemented by Adding an Avalanche and Blocking Diode to the Diode Array. The Blocking Diode Eliminates the  $I_{PU1}$  Current Path; However, Current Path  $I_{PU2}$  will Exist if the IC has a Diode Connected between the Output and Power Supply Pins**

**Differential Amplifier Circuits**

The different clamping voltages of uni and bidirectional TVS devices sometimes can make a difference in the noise performance of a differential input or output circuit. The differences between the two TVS devices can be shown by reviewing the clamping characteristics of a large sine wave that is representative of a noise signal, as shown in Figure 12. The uni and bidirectional TVS devices convert

a sine wave into a square wave with a DC average of approximately  $V_{BR}/2$  and 0 V, respectively. Amplifiers typically have better noise rejection specifications if the average of the input signal is equal to zero volts. Also, biasing the average of the noise signal to 0 V can reduce the hum in an audio amplifier that is associated with a DC bias voltage.



**Figure 12. The Average Clamping Voltage of a Unidirectional TVS Diode for a Sine Wave Input is  $V_{BR}/2$ . The Symmetrical Breakdown Voltages of a Bidirectional Device has an Average Clamping Voltage that is Biased at 0 V**

The remote sensor amplifier circuit shown in Figure 13 illustrates the advantages of symmetrical clamping. A remote sensor is connected to the amplifier via long wires, which often introduces noise into the electronics. The shielded twisted-pair cable minimizes radiated interference

from inducing a voltage on the signal lines and the feed-through capacitors in the connector reduce the noise before the input lines enter the PCB. Next, an amplifier provides the differential amplification to magnify the sensor signal and attenuate the noise signal.

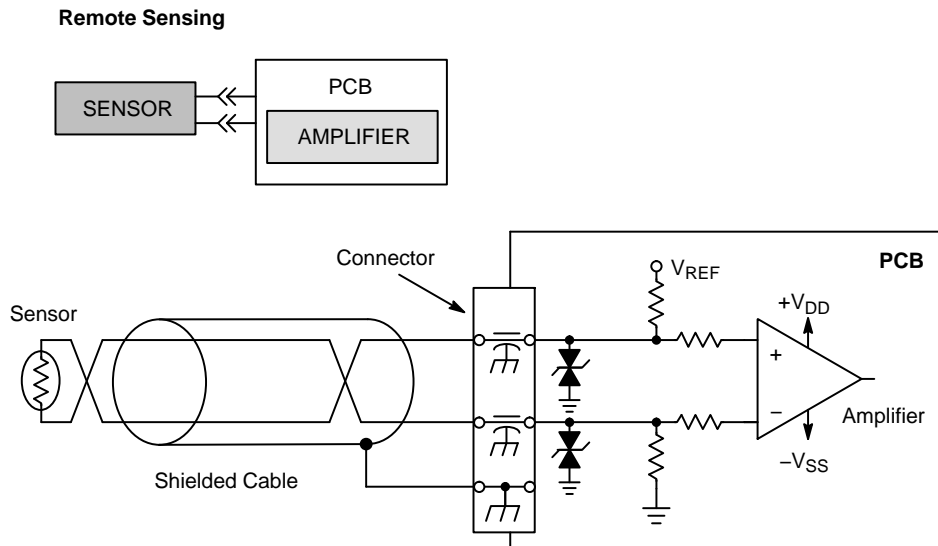

**Figure 13. Remote Sensor Circuits are an Example of an Application that Can Benefit from the Symmetrical Clamping Feature of a Bidirectional TVS Diode**

An ideal amplifier has an infinite Common Mode Rejection Ratio (CMRR) and will only amplify the voltage difference between the two input pins. In contrast, a practical amplifier has a high CMRR at low frequencies, but the CMRR decreases as the frequency increases. The error that occurs from the deviation from the ideal amplifier characteristics can be minimized by preventing as much noise as possible from entering the circuit board and by using a bidirectional TVS device. The ideal amplifier will reject all signals that are common to the two signal lines; however, a practical amplifier typically has better amplification and CMRR characteristics if the signal is based at the mid-point of the supply voltage, which is ground for a dual power supply (+V<sub>DD</sub>, -V<sub>SS</sub>) device. In contrast, the optimal bias point of the noise signal is usually equal to V<sub>DD</sub>/2 for single power supply (+V<sub>DD</sub>, V<sub>SS</sub> = 0 V) amplifiers.

The remote sensor circuit also demonstrates a common solution for solving the non-ideal frequency response of a TVS device. Placing an RF capacitor such as a feed-through capacitor in parallel with the TVS device can cancel the parasitic inductance term produced by the diode's package. The frequency response of a TVS diode can be modeled by connecting a resistor, inductor and capacitor in series, as shown in Figure 14. At low frequencies below 500 to 800 MHz for an SMT package, the inductance term is relatively small and the capacitive impedance is large; thus, the device functions as a near-ideal capacitor. At high frequencies, the inductance term becomes large, while the capacitive term becomes small and the device functions as an inductor. The change in impedance has the consequences that the input signal can be rectified and amplified, instead of attenuated.

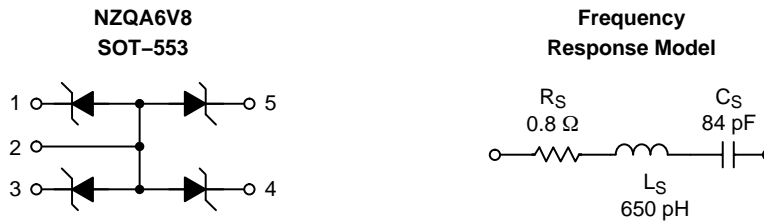

**Figure 14. The Frequency Response of an Avalanche TVS Diode can be Modeled by a Resistor, Inductor and Capacitance that are Connected in Series. This Model is Valid for Signals that are Smaller in Magnitude than the Clamping Voltage**

**Bibliography**

- [1] -, “AP-209 – Design Considerations for ESD Protection Using ESD Protection Diode Arrays”, California Micro Devices, 1998.
- [2] -, “App. Note 0007 – TVS Device Selection, Location and Connection for EMC Design”, Protek, 1997.
- [3] Lepkowski, J., “AND8031 – Circuit Configuration Options for Transient Voltage Suppression Diodes”, 2005.
- [4] Lepkowski, J., “AND8032 – PCB Design Guidelines that Maximize the Performance of TVS Diodes”, 2005.

Littelfuse products are not designed for, and shall not be used for, any purpose (including, without limitation, automotive, military, aerospace, medical, life-saving, life-sustaining or nuclear facility applications, devices intended for surgical implant into the body, or any other application in which the failure or lack of desired operation of the product may result in personal injury, death, or property damage) other than those expressly set forth in applicable Littelfuse product documentation. Warranties granted by Littelfuse shall be deemed void for products used for any purpose not expressly set forth in applicable Littelfuse documentation. Littelfuse shall not be liable for any claims or damages arising out of products used in applications not expressly intended by Littelfuse as set forth in applicable Littelfuse documentation. The sale and use of Littelfuse products is subject to Littelfuse Terms and Conditions of Sale, unless otherwise agreed by Littelfuse.