

Date: - 1<sup>st</sup> June, 2017

Data Sheet Issue: - 2

# Water Cooled Heatsink Type XW180GA34#

## Characteristics – Double side cooling, 2 coolers + 1 Semiconductor

|                       | PARAMETER                             | TYP. | TEST CONDITIONS                | UNITS |
|-----------------------|---------------------------------------|------|--------------------------------|-------|
| R <sub>th (C/W)</sub> | Cooler-input water thermal resistance | 3    | 6l/m flow rate, Power – 2.5kW  | K/kW  |
| R <sub>th (C/W)</sub> | Cooler-input water thermal resistance | 2.3  | 10l/m flow rate, Power – 2.5kW | K/kW  |

## Characteristics – Double side cooling, 3 coolers + 2 Semiconductors

|                       | PARAMETER                             | TYP. | TEST CONDITIONS                | UNITS |
|-----------------------|---------------------------------------|------|--------------------------------|-------|
| R <sub>th (C/W)</sub> | Cooler-input water thermal resistance | 3.8  | 6l/m flow rate, Power – 2.5kW  | K/kW  |
| R <sub>th (C/W)</sub> | Cooler-input water thermal resistance | 2.7  | 10l/m flow rate, Power – 2.5kW | K/kW  |

## Physical/Electrical properties

|    | PARAMETER   | MIN.                | TYP. | MAX. | TEST CONDITIONS | UNITS |
|----|---|---------------------|------|------|-----------------|-------|
| ΔP | Pressure difference between input and output water per cooler | -                   | 63   | -    | 6l/m            | kPa   |
| ΔP | Pressure difference between input and output water per cooler | -                   | 140  | -    | 10l/m           | kPa   |
| M  | Mass without busbar (XW180GC34A)                              | -                   | 1.49 | -    |                 | kg    |
| M  | Mass with busbar (XW180GC34B)                                 | -                   | 1.79 | -    |                 | kg    |
|    | Dimensions  | See outline drawing |      |      |                 |       |

## Mechanical properties

|   | PARAMETER                 | MIN.                       | TYP. | MAX. | UNITS             |
|---|---------------------------|----------------------------|------|------|-------------------|
|  | Flatness of contact area  | -                          | 20   | -    | μm                |
| Ra  | Roughness of contact area | -                          | 0.8  | -    | μm                |
|   | Clamping force            | -                          | -    | 13   | N/mm <sup>2</sup> |
|   | Finish of contact area    | Nickel-plating 10μm bright |      |      |                   |
|   | Hydraulic fitting         | 3/8" BSPP                  |      |      |                   |

\* For other busbar/mechanical configurations please consult the factory.

## Notes

The graphs on the following pages are typical values at 2500W.

### 1.0 - Temperature reference points

Heatsink – in the cooler within 2mm of device centre  
 Ambient – water temperature at the assembly input.

### 2.0 - Multiple cooler stacks

#### 2.1 - 2 coolers/1 semiconductor

The temperature of the water entering the last cooler pair should be taken into account. The temperature rise of cooling water along the stack with respect to the ambient input water is  $(\Delta T)W$  according to the formula shown below: -

$$(\Delta T)W = \frac{14.4 * P(n - 1)}{F}$$

Where P is the power (in kW) dissipated in the semiconductor  
 n is the number of semiconductors  
 F is the water flow in Litres/min.

The rise in temperature of the last cooler pair with respect to the ambient input water is then: -

$$(\Delta T)C = (\Delta T)W + P * R_{thCW}$$

Where  $R_{thCW}$  is obtained from the curve for double side cooling on page 3

#### 2.2 - (n + 1) coolers/n semiconductors (n greater than 2)

In any series stack of coolers with n greater than two, the hottest cooler will usually be the penultimate one in the down stream direction.

The inlet water temperature rise to the last but one cooler (relative to stack inlet) may be calculated according to:

$$(\Delta T)W = \frac{14.4 * P(2n - 3)}{2F}$$

The effective temperature rise of the penultimate cooler with respect to the stack input water is given by:

$$(\Delta T)C = (\Delta T)W + P * R_{thCW}$$

Where  $R_{thCW}$  is obtained from the curve for 3 coolers on page 3

**Curves**

Figure 1 – Steady state thermal resistance vs Water flow

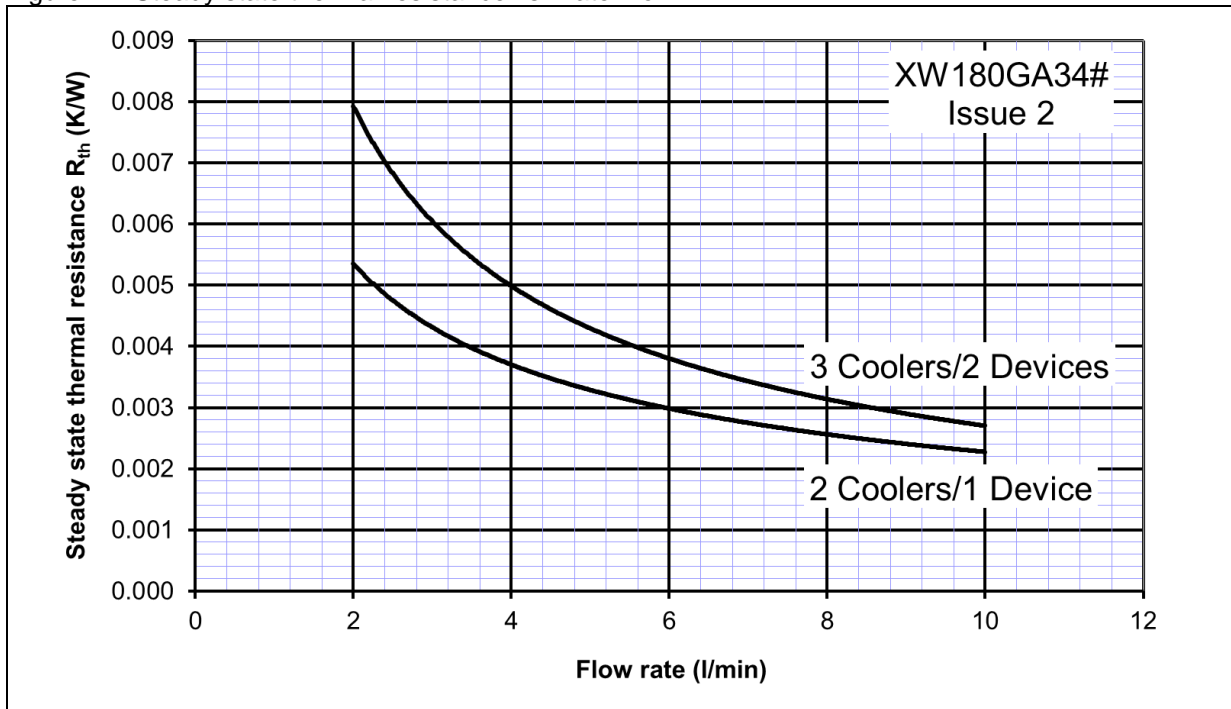

Figure 2 – Transient thermal impedance vs Time

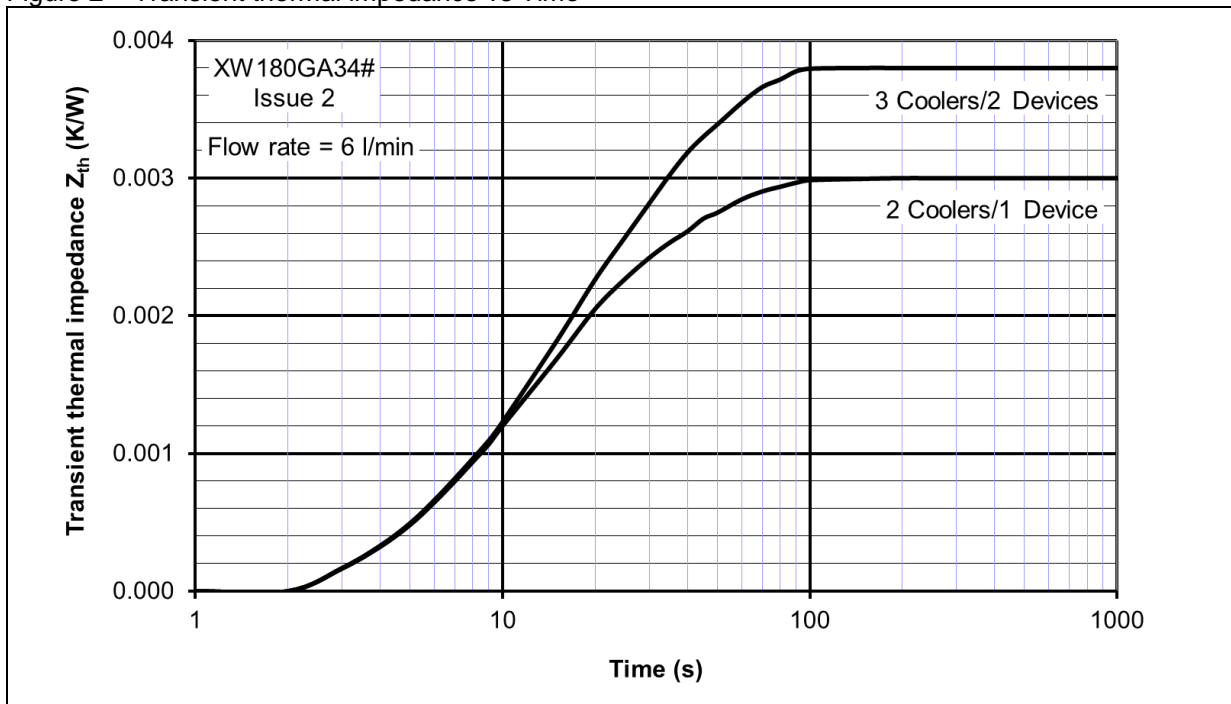
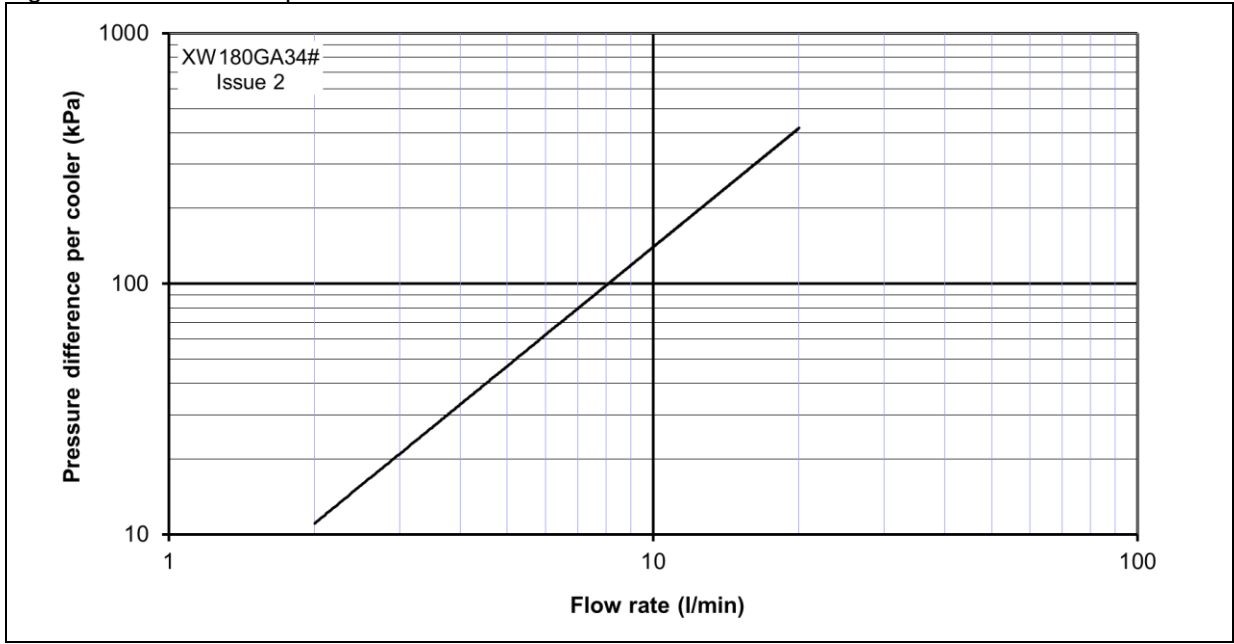
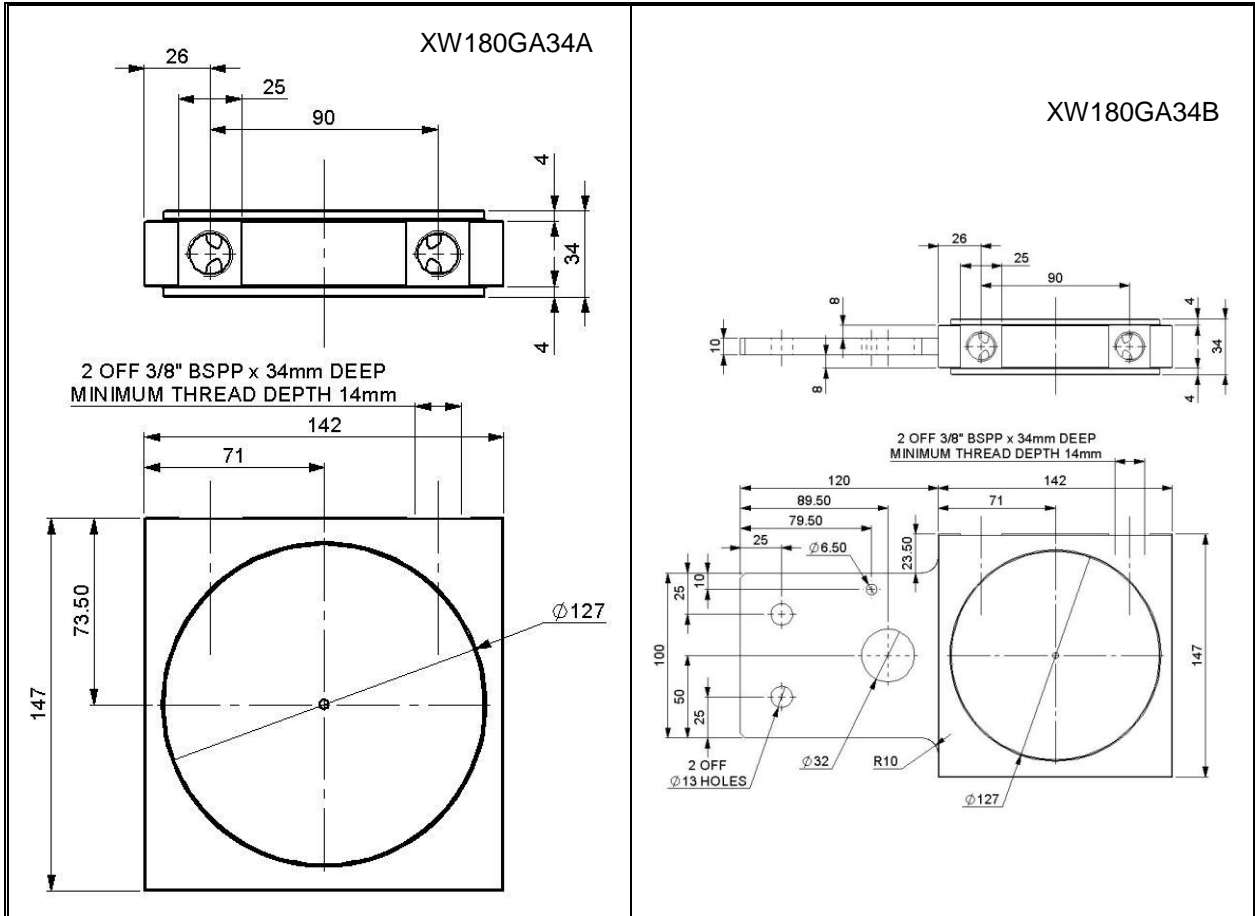

Figure 3 – Pressure drop vs Water flow



**Outline Drawing & Ordering Information**



**ORDERING INFORMATION**

(Please quote order code as below)

| <b>XW</b>    | <b>180</b>                   | <b>G</b>                  | <b>A</b>                  | <b>34</b>             | <b>#</b>                    |
|--------------|------------------------------|---------------------------|---------------------------|-----------------------|-----------------------------|
| Water cooler | Maximum flange diameter (mm) | Nominal poleface diameter | Material<br>A = Aluminium | Cooler thickness (mm) | A = No busbar<br>B = Busbar |

Typical order code: XW180GA34A – Assemblies water cooler, 180mm maximum flange diameter, made from aluminium, 34mm thick with no busbar.

**IXYS Semiconductor GmbH**  
Edisonstraße 15  
D-68623 Lampertheim  
Tel: +49 (62 06) 503-0  
Fax: +49 (62 06) 503-627  
E-mail: [marcom@ixys.de](mailto:marcom@ixys.de)



**IXYS UK Westcode Ltd**  
Langley Park Way, Langley Park,  
Chippenham, Wiltshire, SN15 1GE.  
Tel: +44 (0)1249 444524  
Fax: +44 (0)1249 659448  
E-mail: [sales@ixysuk.com](mailto:sales@ixysuk.com)

**IXYS Corporation**  
1590 Buckeye Dr.  
Milpitas CA 95035-7418  
Tel: +1 (408) 457-9000  
Fax: +1 (408) 496-06 70  
E-mail: [sales@ixys.net](mailto:sales@ixys.net)

[www.ixysuk.com](http://www.ixysuk.com)

[www.ixys.net](http://www.ixys.net)

**IXYS Long Beach**  
IXYS Long Beach, Inc  
2500 Mira Mar Ave, Long Beach  
CA 90815  
Tel: +1 (562) 296 6584  
Fax: +1 (562) 296 6585  
E-mail: [service@ixyslongbeach.com](mailto:service@ixyslongbeach.com)

The information contained herein is confidential and is protected by Copyright. The information may not be used or disclosed except with the written permission of and in the manner permitted by the proprietors IXYS UK Westcode Ltd.

© IXYS UK Westcode Ltd.

In the interest of product improvement, IXYS UK Westcode Ltd reserves the right to change specifications at any time without prior notice.



---

Disclaimer Notice - Information furnished is believed to be accurate and reliable. However, users should independently evaluate the suitability of and test each product selected for their own applications. Littelfuse products are not designed for, and may not be used in, all applications. Read complete Disclaimer Notice at [www.littelfuse.com/disclaimer-electronics](http://www.littelfuse.com/disclaimer-electronics).