

# SP00R6

## 0.2pF, 12KV Diode, Low Voltage Low Capacitance ESD Protection

HF **RoHS** **Pb**

Note: This package image is for example and reference only. For detail package drawing, please refer to the package section in this datasheet.

### Pinout

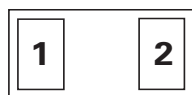

### Functional Block Diagram



### Description

The SP00R6 features extremely low breakdown/turn on voltages, making them more ideal protectors of low voltage -0.3 to +0.3V data lines. These robust diodes can safely absorb repetitive ESD strikes above the maximum level specified in IEC 61000-4-2 international standard (Level 4, ±8kV contact discharge) without performance degradation.

### Features

- ESD, IEC 61000-4-2, ±12 contact, ±15kV air
- EFT, IEC 61000-4-4, 30A (5/50ns)
- Surge Tolerance, IEC 61000-4-5 2nd Edition, 3A (8/20us)
- Low capacitance of 0.2pF (TYP)
- Space efficient 0201 package
- Halogen-free, lead-free and RoHS-compliant

### Applications

- USB 3.x
- Thunderbolt 4 or 3
- USB4(TM)
- USB 3.2 Gen 2x2
- USB 3.2 Gen 2
- PCI Express 6.0

#### Life Support Note:

Not Intended for Use in Life Support or Life Saving Applications

The products shown herein are not designed for use in life sustaining or life saving applications unless otherwise expressly indicated.

# SP00R6

## 0.2pF, 12KV Diode, Low Voltage Low Capacitance ESD Protection

### Absolute Maximum Ratings

Symbol	Parameter	Value	Units
$I_{PP}$	Peak Current ( $t_p=8/20\mu s$ )	3	A
$T_{OP}$	Operating Temperature	-40 to 125	°C
$T_{STOR}$	Storage Temperature	-55 to 150	°C

**CAUTION:** Stresses above those listed in "Absolute Maximum Ratings" may cause permanent damage to the component. This is a stress only rating and operation of the component at these or any other conditions above those indicated in the operational sections of this specification is not implied.

### Electrical Characteristics ( $T_{OP}=25^\circ C$ )

Parameter	Symbol	Test Conditions	Min	Typ	Max	Units
Reverse Standoff Voltage	$V_{RWM}$				0.3	V
Breakdown Voltage	$V_{BR}$	$I_R=1mA$	0.7		0.9	V
Reverse Leakage Current	$I_{LEAK}$	$V_R=0.3V$ , Any I/O to GND			100	nA
Clamp Voltage <sup>1</sup>	$V_C$	$I_{PP}=1A$ , $t_p=8/20\mu s$		2.0		V
		$I_{PP}=2A$ , $t_p=8/20\mu s$		2.5		
Dynamic Resistance <sup>3</sup>	$R_{DYN}$	TLP, $t_p=100ns$		0.3		$\Omega$
ESD Withstand Voltage <sup>1</sup>	$V_{ESD}$	IEC 61000-4-2 (Contact Discharge)	$\pm 12$			kV
		IEC 61000-4-2 (Air Discharge)	$\pm 15$			kV
Line Capacitance <sup>1,2</sup>	$C_L$	Reverse Bias=0V, $f=3GHz$		0.2		pF

Note 1: Parameter is guaranteed by design and/or component characterization.

Note 2: Test equipment accuracy  $\pm 50fF$ .

Note 3: Transmission Line Pulse (TLP) with 100ns width, 2ns rise time, and average window  $t1=70ns$  to  $t2=90ns$

#### 8/20 $\mu s$ Pulse Waveform

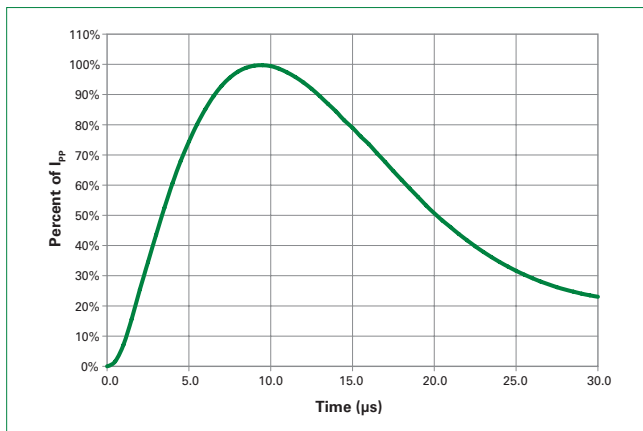

#### Clamping Voltage vs $I_{PP}$

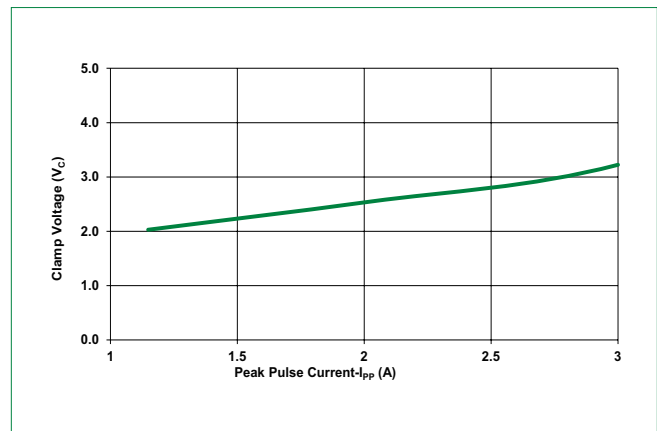

# SP00R6

## 0.2pF, 12KV Diode, Low Voltage Low Capacitance ESD Protection

IEC 61000-4-2 +8 kV Contact ESD Clamping Voltage

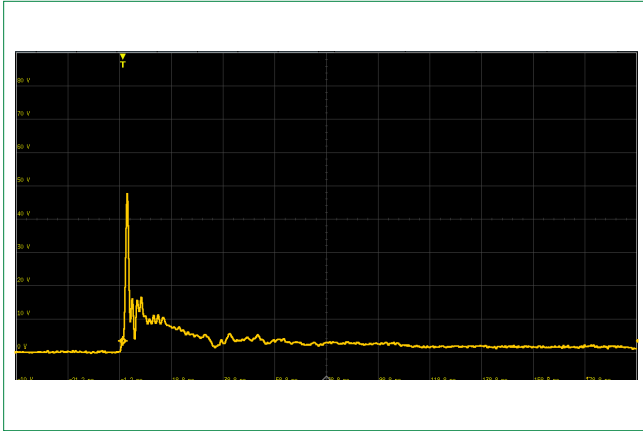

IEC 61000-4-2 -8 kV Contact ESD Clamping Voltage

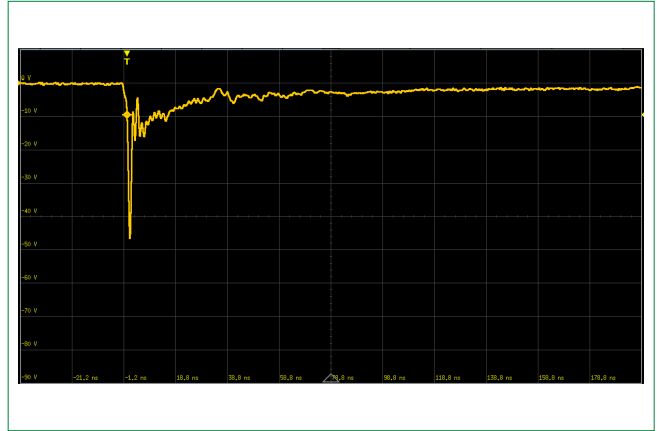

Positive Transmission Line Pulsing (TLP) Plot

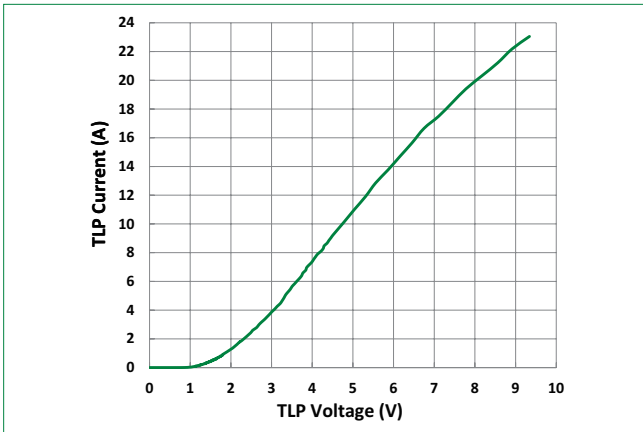

Negative Transmission Line Pulsing (TLP) Plot

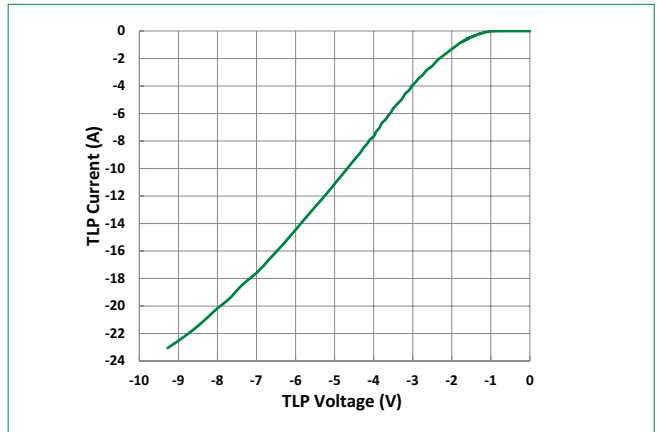

IV curve

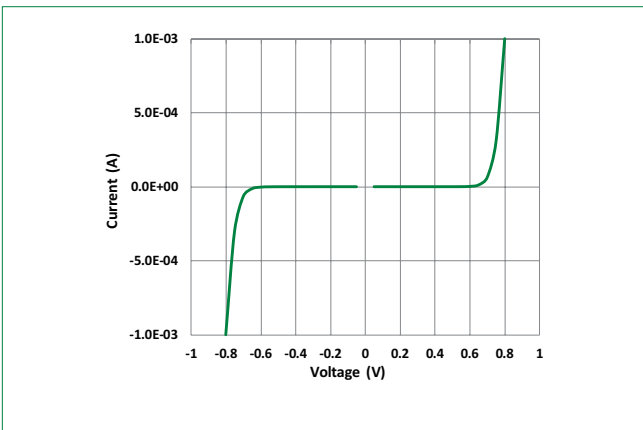

# SP00R6

## 0.2pF, 12KV Diode, Low Voltage Low Capacitance ESD Protection

### Soldering Parameters

<b>Reflow Condition</b>		Pb – Free assembly
<b>Pre Heat</b>	- Temperature Min ( $T_{s(min)}$ )	150°C
	- Temperature Max ( $T_{s(max)}$ )	200°C
	- Time (min to max) ( $t_s$ )	60 – 120 secs
<b>Average ramp up rate (Liquidus) Temp (<math>T_L</math>) to peak</b>		3°C/second max
<b><math>T_{s(max)}</math> to <math>T_L</math> - Ramp-up Rate</b>		3°C/second max
<b>Reflow</b>	- Temperature ( $T_L$ ) (Liquidus)	217°C
	- Temperature ( $t_L$ )	60 – 150 seconds
<b>Peak Temperature (<math>T_p</math>)</b>		260 <sup>+0/-5</sup> °C
<b>Time within 5°C of actual peak Temperature (<math>t_p</math>)</b>		30 seconds
<b>Ramp-down Rate</b>		6°C/second max
<b>Time 25°C to peak Temperature (<math>T_p</math>)</b>		8 minutes Max.
<b>Do not exceed</b>		260°C

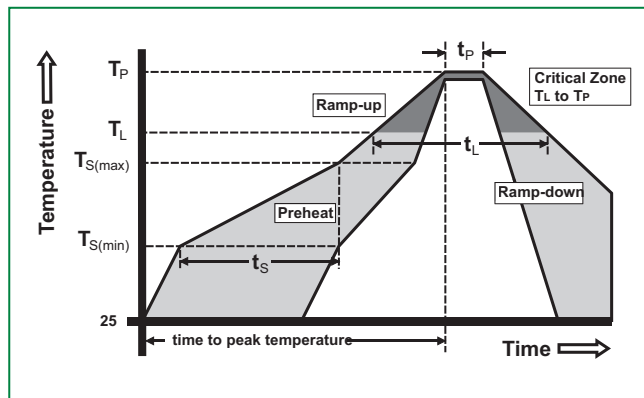

### Ordering Information

Part Number	Package	Min. Order Qty.
SP00R6-01WTG	Flipchip	10000

### Part Marking System



### Product Characteristics

<b>Lead Plating</b>	Tin plating
<b>Lead material</b>	Copper bump
<b>Substrate Material</b>	Silicon
<b>Flammability</b>	UL Recognized compound meeting flammability rating V-0

### Part Numbering System

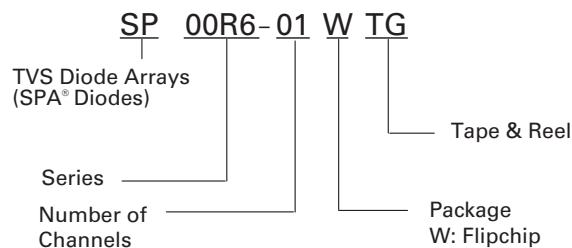

**SP00R6**

0.2pF, 12KV Diode, Low Voltage Low Capacitance ESD Protection

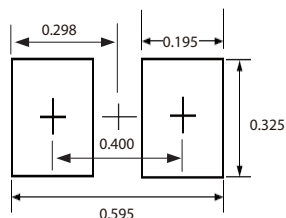
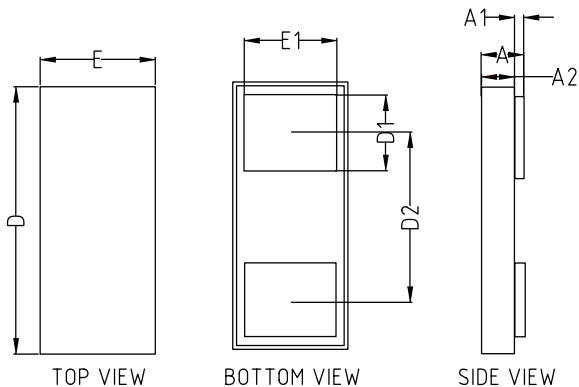
**Package Dimensions — FLIPCHIP**

Recommended Soldering Pad Layout (mm)

Symbol	0201 Flipchip			
	Millimeters		Inches	
	Min	Max	Min	Max
D	0.605	0.655	0.0238	0.0258
E	0.305	0.355	0.0120	0.0140
D1	0.145	0.155	0.0057	0.0061
E1	0.245	0.255	0.0096	0.0100
D2	0.400 BSC		0.0157 BSC	
A	0.273	0.329	0.0107	0.0130
A2	0.265	0.315	0.0104	0.0124
A1	0.008	0.014	0.0003	0.0006

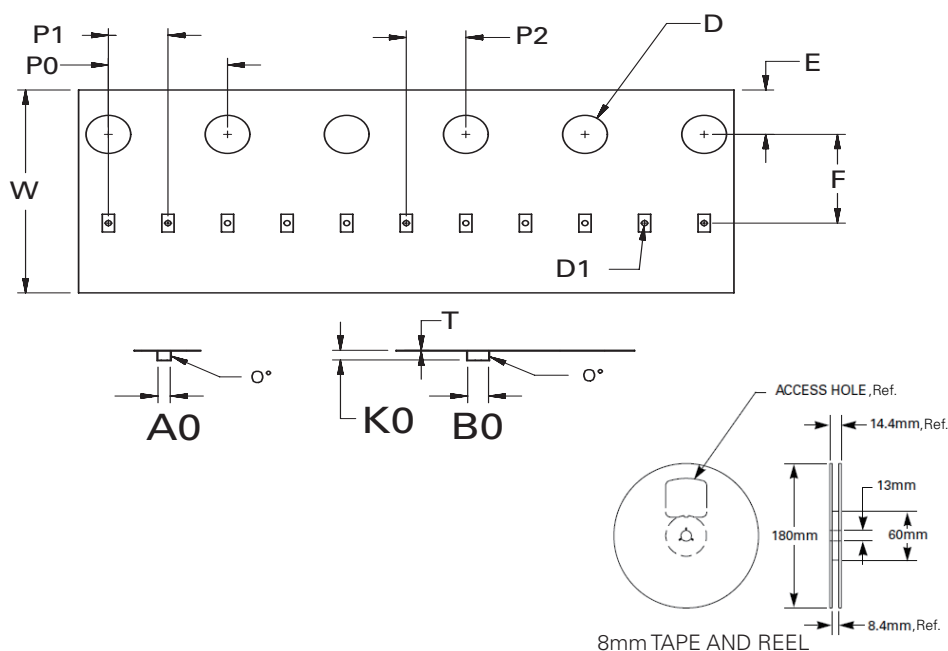
**Embossed Carrier Tape & Reel Specification — FLIPCHIP**

Symbol	Millimeters
A0	0.41+/-0.03
B0	0.70+/-0.03
D	ø 1.50 + 0.10
D1	ø 0.20 +/- 0.05
E	1.75+/-0.10
F	3.50+/-0.05
K0	0.38+/-0.03
P0	4.00+/-0.10
P1	2.00+/-0.05
P2	2.00+/-0.05
W	8.00+0.30/-0.10
T	0.23+/-0.02

**Product Disclaimer:** Littelfuse products are not designed for, and shall not be used for, any purpose (including, without limitation, automotive, military, aerospace, medical, life-saving, life-sustaining or nuclear facility applications, devices intended for surgical implant into the body, or any other application in which the failure or lack of desired operation of the product may result in personal injury, death, or property damage) other than those expressly set forth in applicable Littelfuse product documentation. Warranties granted by Littelfuse shall be deemed void for products used for any purpose not expressly set forth in applicable Littelfuse documentation. Littelfuse shall not be liable for any claims or damages arising out of products used in applications not expressly intended by Littelfuse as set forth in applicable Littelfuse documentation. The sale and use of Littelfuse products is subject to Littelfuse Terms and Conditions of Sale, unless otherwise agreed by Littelfuse. "Littelfuse" includes Littelfuse, Inc., and all of its affiliate entities. <http://www.littelfuse.com/disclaimer-electronics>.