

# Motor and Pump Protection Relays

## 111p Series

### Single-Phase Pump Monitor



### Description

The Littelfuse models 111P (115 volt, 1/3 to 1hp); 233P-1.5 (230 volt, 1/3 to 1.5hp); and 233P (230 volt, 1/3 to 3hp) are single-phase pump monitors used in a variety of applications to protect from dry-well, dead-head, jammed impeller, rapid-cycling, overvoltage, and undervoltage conditions.

### Operation

A calibration adjustment allows the unit to be calibrated to your specific pumping applications, which reduces the possibility of false or nuisance tripping. A unique microcontroller-based voltage and current-sensing circuit constantly monitor the incoming power for fluctuations, overcurrent, and undercurrent conditions. When an abnormality, such as loss of suction, is detected, the product deactivates its output relay and directly disconnects the pump motor. The relay then begins its user-selectable restart delay (dry-well recovery) timer. When the timer counts to zero or power is removed and reapplied, the relay reactivates its output relay and turns the pump back on. The infrared LED communicates with a hand-held diagnostics tool called the Informer\* (sold separately). The Informer displays parameters including calibration points, trip points, run time and last faults.

There are special considerations for pump cables larger than #10 AWG: In some cases where larger motors are installed with deep-set pumps, pump cables are used that exceed the relay's terminal size. In these conditions, a short splice of #10 AWG or #12 AWG may be a solution at the control box. Note: All local, state, and national electric codes should be followed when applying this solution.

Note: The description and operations apply to Littelfuse models 111P (115 V, 1/3 to 1 hp); 233P-1.5 (230 V, 1/3 to 1.5 hp); and 233P (230 V, 1/3 to 3 hp). These models have a sensitivity adjustment for the dry-well trip point. After calibration is complete, you can adjust the sensitivity for the dry-well/dead-head trip point from 70-90 % of the full load. This makes the unit even more adaptable to varying pumping applications. If you have a very low producing well, you increase the sensitivity closer to the 90 % mark, or if you have a very heavy producing well, you should decrease the sensitivity around the 70 % mark.

\*Informer: A hand-held diagnostic tool that uses an infrared receiver to access information that can be helpful for troubleshooting the system.

### Features & Benefits

FEATURES	BENEFITS
<b>Proprietary microcontroller-based circuitry</b>	Constant monitoring of voltage, power factor, and current for reliable pump protection
<b>Onboard calibration process</b>	Calibrates unit to your specific individual pumping application and reduces nuisance tripping
<b>Onboard sensitivity adjustment</b>	User-adjustable sensitivity knob makes the unit more adaptable to varying pumping applications

# Motor and Pump Protection Relays

## 111p Series

### Applications

- Pumps: submersible, centrifugal, circulating, cooling, environmental
- Waterwells: residential, commercial, irrigation
- Golf course systems
- Sprinkler systems

### Specifications

#### Functional Characteristics

##### Adjustments/Settings:

<b>Overcurrent</b>	125% of calibration point
<b>Underload (dry-well)</b>	Adjustable (70 to 90% of calibrated run power)
<b>Overvoltage</b>	132.5VAC
<b>Undervoltage</b>	95VAC
<b>Number of restarts allowed in a 60-sec. period (rapid-cycling)</b>	4

##### Trip Delay Times

<b>Overcurrent</b>	5 seconds
<b>Dry-well</b>	4 seconds

##### Restart Delay Times

<b>Over/Undervoltage</b>	2 seconds
<b>All other faults</b>	Manual, 2-225 Minutes

##### Input Characteristics

<b>Supply Voltage</b>	115VAC
<b>Load Range</b>	1/3 – 1 hp
<b>Frequency</b>	50/60Hz (Note: 50Hz will increase all delay timers by 20%)

##### Output Characteristics

<b>Output Contact Rating-SPST</b>	1hp@120VAC (16 amps max.)
-----------------------------------	---------------------------

##### General Characteristics

<b>Operating Temperature</b>	-40° to 55° C (-40° to 131° F)
<b>Maximum Input Power</b>	5 W
<b>Wire Gauge</b>	Solid or Stranded 10 - 22AWG
<b>Terminal Torque</b>	13 in.-lbs.
<b>Dimensions</b>	<b>H</b> 73.66 mm (2.9"); <b>W</b> 133.35 mm (5.25"); <b>D</b> 73.99 mm (2.913")
<b>Weight</b>	14 oz.
<b>Mounting Methods</b>	#8 screws

### Certification & Compliance

cULus

Listed UL508, C22.2 No. 14

### Accessories

#### Informer

A hand-held diagnostic tool that uses an infrared receiver to access information which can be helpful for troubleshooting the system.

### Ordering Information

MODEL	LINE VOLTAGE	DESCRIPTION
111P	115VAC	Load Range: 1/3 - 1hp
111P-ENCL	115VAC	111P with NEMA3R enclosure

# Motor and Pump Protection Relays

111p Series

## Dimensions Inches (mm)

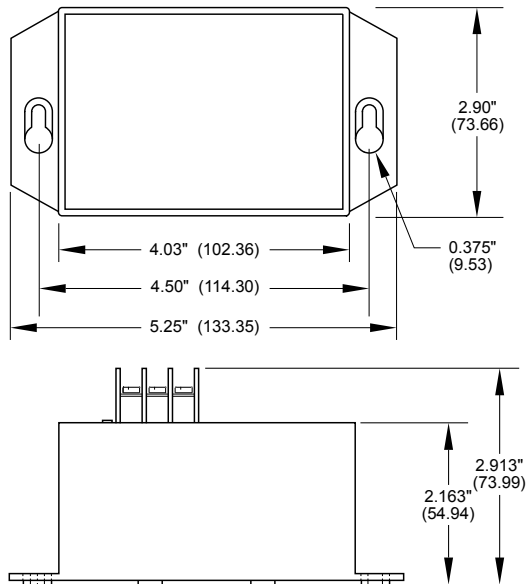

## Simplified Wiring Diagram

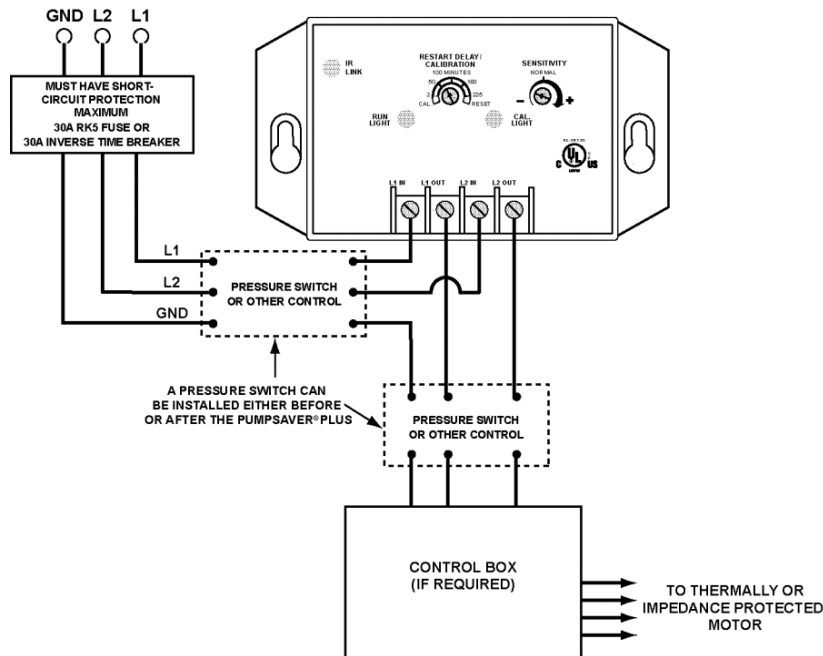

**Disclaimer Notice** – Information furnished is believed to be accurate and reliable. However, users should independently evaluate the suitability of and test each product selected for their own applications. Littelfuse products are not designed for, and may not be used in, all applications. Read complete Disclaimer Notice at [www.littelfuse.com/product-disclaimer](http://www.littelfuse.com/product-disclaimer).