

# SZ5KASMC Series

## Automotive, Surface Mount 5000 W In DO-214AB



### Additional Information



Resources



Accessories



Samples

### Agency Approvals

Agency	Agency File Number
	E128662

### Maximum Ratings & Thermal Characteristics

Parameter	Symbol	Value	Unit
Peak Power Dissipation (Note 1) @ $T_L = 25^\circ\text{C}$ , Pulse Width = 1 ms	$P_{PPM}$	5000	W
DC Power Dissipation @ $T_L = 75^\circ\text{C}$ Measured Zero Lead Length (Note 2) Derate Above $75^\circ\text{C}$	$P_D$	5.4 54.6	W $\text{mW}/^\circ\text{C}$
DC Power Dissipation (Note 3) @ $T_A = 25^\circ\text{C}$ Derate Above $25^\circ\text{C}$	$P_D$	2.0 13.3	W $\text{mW}/^\circ\text{C}$
Operating and Storage Temperature Range	$T_J$ $T_{stg}$	-65 to +175	$^\circ\text{C}$
Thermal Resistance from Junction-to-Ambient	$R_{\theta JA}$	75	$^\circ\text{C}/\text{W}$
Thermal Resistance from Junction-to-Lead	$R_{\theta JL}$	18.3	$^\circ\text{C}/\text{W}$

Stresses exceeding maximum ratings may damage the device. Maximum ratings are stress ratings only. Functional operation above the recommended operating conditions is not implied. Extended exposure to stresses above the recommended operating conditions may affect device reliability.

1.  $10 \times 1000 \mu\text{s}$ , non-repetitive.
2. 1 inch square copper pad, FR-4 board.
3. FR-4 board, using Littelfuse minimum recommended footprint

### Description

The SZ5KASMC series is designed to protect voltage sensitive components from high voltage, high energy transients. They have excellent clamping capability, high surge capability, low zener impedance and fast response time. The SZ5KASMC series is supplied in cost-effective, highly reliable DO-214AB package and it is ideal for use in automotive electronic applications.

### Features and Benefits

- Automotive grade, AEC-Q101 qualified and PPAP capable
- Peak power – 5000 W@1 ms
- Working peak reverse voltage range - 10 V to 36 V for Bi-directional
- Standard zener breakdown voltage range - 11.1 V to 44.2 V
- Compact design in DO-214AB package
- ESD protection of data lines in accordance with IEC 61000-4-2 30 kV (Air), 30 kV (Contact)
- ESD rating of class 3 (>16 kV) per human body model
- Zener transient overvoltage suppressors
- Excellent clamping capability
- UL recognized compound meeting flammability rating V-0
- $V_{BR} @ T_J = V_{BR} @ 25^\circ\text{C} \times (1 + \alpha T \times (T_J - 25))$  ( $\alpha T$ : Temperature coefficient, typical value is 0.1%)
- Maximum temperature coefficient specified
- Response time is typically < 1 ns
- These components are Pb-free and are ROHS compliant
- UL recognized as an isolated loop circuit protector to UL 497B

### Applications

TVS devices are ideal for the protection of I/O Interfaces,  $V_{CC}$  bus and other vulnerable circuits used in automotive application.

### Functional Diagram

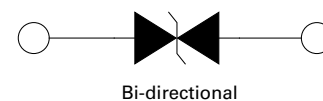

Bi-directional

**SZ5KASMC Series**

Automotive, Surface Mount 5000 W In DO-214AB

**Electrical Characteristics**

Part Number	Marking	Working Peak Reverse Voltage $V_{RWM}$ (V) (Note 5)	Breakdown Voltage $V_{BR}$ (V) @ $I_T$ (Note 6)		Test Current $I_T$ (mA)	Maximum Clamping Voltage $V_C$ @ $I_{PP}$ (Note 7) (V)	Maximum Peak Pulse Current $I_{PP}$ (A)	Maximum Reverse Leakage $I_R$ @ $V_R$ ( $\mu$ A)	Agency Approval 
			Min	Max					
SZ5KASMC10CAT3G	5BAR	10.0	11.1	12.3	1	17.0	294.1	20	X
SZ5KASMC11CAT3G	5BAT	11.0	12.2	13.5	1	18.2	274.7	20	X
SZ5KASMC12CAT3G	5BEP	12.0	13.3	14.7	1	19.9	251.3	10	X
SZ5KASMC13CAT3G	5BEQ	13.0	14.4	15.9	1	21.5	232.6	10	X
SZ5KASMC14CAT3G	5BER	14.0	15.6	17.2	1	23.2	215.5	5	X
SZ5KASMC15CAT3G	5BES	15.0	16.7	18.5	1	24.4	204.9	5	X
SZ5KASMC16CAT3G	5BET	16.0	17.8	19.7	1	26.0	192.3	5	X
SZ5KASMC17CAT3G	5BEU	17.0	18.9	20.9	1	27.6	181.2	5	X
SZ5KASMC18CAT3G	5BEV	18.0	20.0	22.1	1	29.2	171.2	5	X
SZ5KASMC20CAT3G	5BEW	20.0	22.2	24.5	1	32.4	154.3	5	X
SZ5KASMC22CAT3G	5BEX	22.0	24.4	26.9	1	35.5	140.8	5	X
SZ5KASMC24CAT3G	5BEZ	24.0	26.7	29.5	1	38.9	128.5	5	X
SZ5KASMC26CAT3G	5BFE	26.0	28.9	31.9	1	42.1	118.2	5	X
SZ5KASMC28CAT3G	5BFG	28.0	31.1	34.4	1	45.4	110.1	5	X
SZ5KASMC30CAT3G	5BFK	30.0	33.3	36.8	1	48.4	103.3	5	X
SZ5KASMC33CAT3G	5BFM	33.0	36.7	40.6	1	53.3	93.8	5	X
SZ5KASMC36CAT3G	5BFP	36.0	40.0	44.2	1	58.1	86.1	5	X

5. A transient suppressor is normally selected according to the maximum working peak reverse voltage ( $V_{RWM}$ ), which should be equal to or greater than the DC or continuous peak operating voltage level.

6.  $V_{BR}$  measured at pulse test current  $I_T$  at an ambient temperature of 25 °C.

7. Surge current waveform per figure 2 and decay rate per figure 4 of the general data – 5000 watt at the beginning of this group.

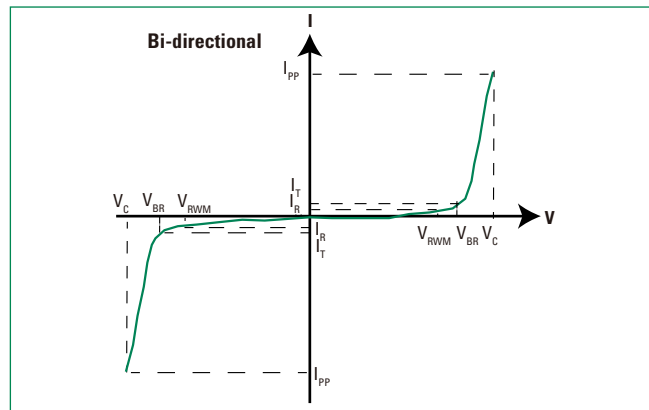
**I-V Curve Characteristics (TA = 25 °C unless otherwise noted) For Bi-directional**

Symbol	Parameter
$I_{PP}$	Maximum Reverse Peak Pulse Current
$V_C$	Clamping Voltage @ $I_{PP}$
$V_{RWM}$	Working Peak Reverse Voltage
$I_R$	Maximum Reverse Leakage Current @ $V_{RWM}$
$V_{BR}$	Breakdown Voltage @ $I_T$
$I_T$	Breakdown Current Current

# SZ5KASMC Series

Automotive, Surface Mount 5000 W In DO-214AB

**Figure 1. Pulse Rating Curve**

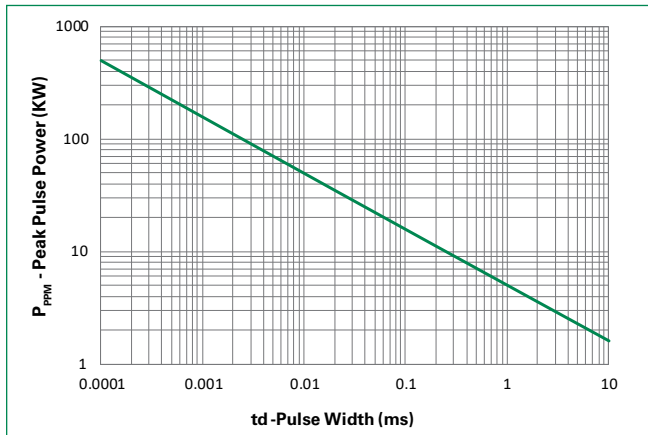

**Figure 2. 10/1000  $\mu$ s Pulse Waveform**

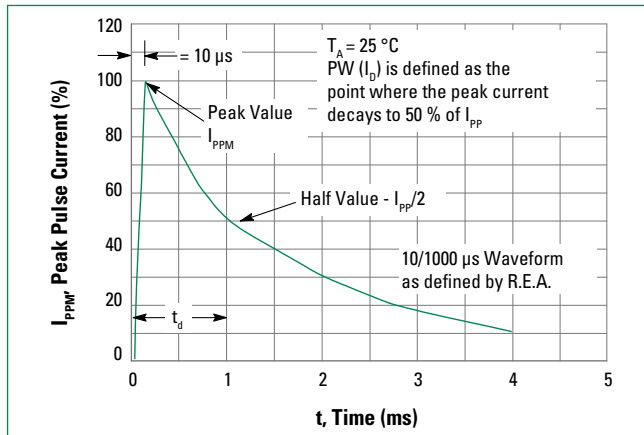

**Figure 3. Typical Junction Capacitance vs. Bias Voltage**

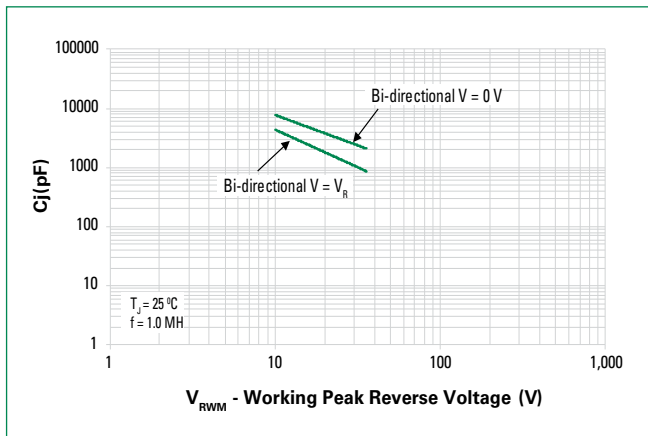

**Figure 4. Surge Derating Curve**

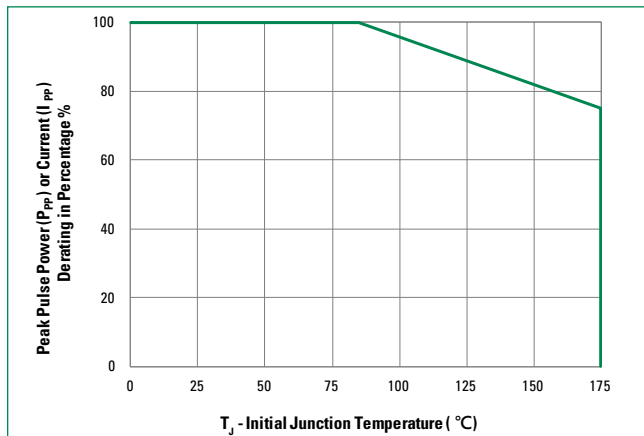

# SZ5KASMC Series

## Automotive, Surface Mount 5000 W In DO-214AB

### Soldering Parameters

<b>Reflow Condition</b>		Lead-free assembly
<b>Pre Heat</b>	- Temperature Min ( $T_{s(min)}$ )	150 °C
	- Temperature Max ( $T_{s(max)}$ )	200 °C
	- Time (min to max) ( $t_s$ )	60 – 120 seconds
<b>Average Ramp Up Rate (Liquidus Temp (<math>T_L</math>) to Peak</b>		3 °C/second max
<b><math>T_{s(max)}</math> to <math>T_L</math> - Ramp-up Rate</b>		3 °C/second max
<b>Reflow</b>	- Temperature ( $T_L$ ) (Liquidus)	217 °C
	- Time (min to max) ( $t_s$ )	60 – 150 seconds
<b>Peak Temperature (<math>T_p</math>)</b>		260 <sup>+0/-5</sup> °C
<b>Time within 5 °C of Actual Peak Temperature (<math>t_p</math>)</b>		30 seconds max
<b>Ramp-down Rate</b>		6 °C/second max
<b>Time 25 °C to Peak Temperature (<math>T_p</math>)</b>		8 minutes max.
<b>Do Not Exceed</b>		260 °C

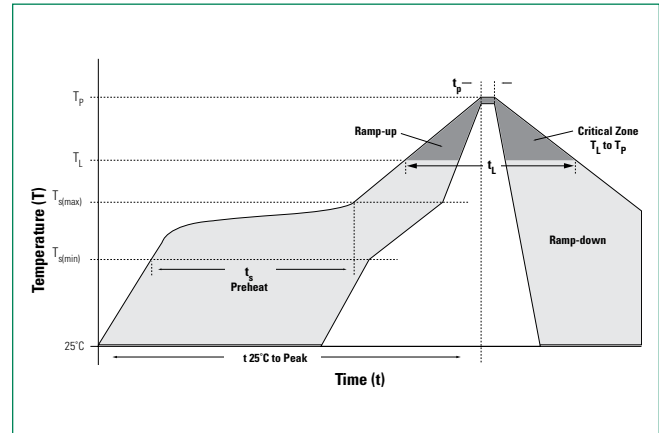

### Physical Specifications

<b>Weight</b>	0.00733 ounce, 0.228 grams
<b>Case</b>	JEDEC DO-214AB. Void-free, transfer-molded, thermosetting plastic epoxy meets UL 94V-0
<b>Polarity</b>	Color band denotes cathode except bidirectional
<b>Terminal</b>	Matte Tin-plated leads, solderable per JESD22-B102

### Environmental Specifications

<b>High Temperature Storage</b>	JESD22-A103
<b>HTRB</b>	JESD22-A108
<b>Temperature Cycling</b>	JESD22-A104
<b>MSL</b>	JEDEC J-STD-020, Level 1
<b>H3TRB</b>	JESD22-A101
<b>RSH</b>	JESD22-A111

### Dimensions

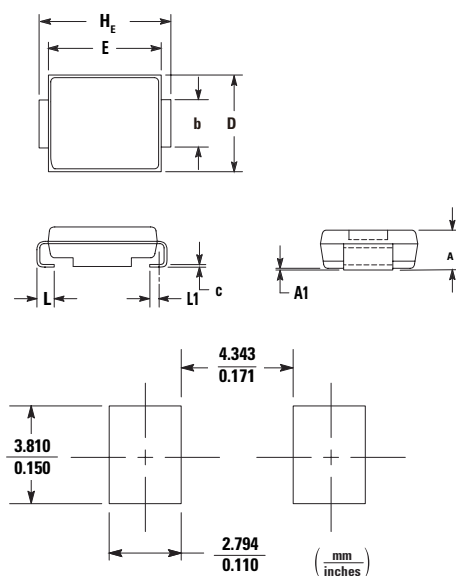

Soldering Footprint

Dim	Inches			Millimeters		
	Min	Nom	Max	Min	Nom	Max
A	0.079	0.087	0.095	2.00	2.22	2.41
A1	0.002	0.004	0.008	0.05	0.10	0.20
b	0.115	0.118	0.125	2.92	3.00	3.18
c	0.006	0.009	0.012	0.15	0.23	0.30
D	0.220	0.230	0.240	5.59	5.84	6.10
E	0.260	0.270	0.280	6.60	6.86	7.11
H <sub>E</sub>	0.305	0.313	0.320	7.75	7.94	8.13
L	0.030	0.040	0.050	0.76	1.02	1.27
L1	0.020 REF			0.51 REF		

### Ordering Information

Device	Package	Shipping
SZ5KASMCxxCAT3G	SMC (Pb-Free)	2,500 / Tape & Reel

# SZ5KASMC Series

## Automotive, Surface Mount 5000 W In DO-214AB

### Part Numbering System

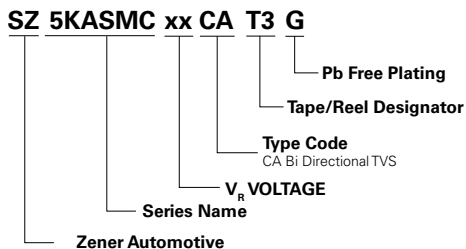

### Part Marking System

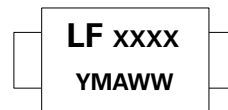

**XXXX** = Marking Code  
**Y** = Year  
**M** = Month  
**A** = Assembly Location  
**WW** = Lot Code

### Tape and Reel Specification

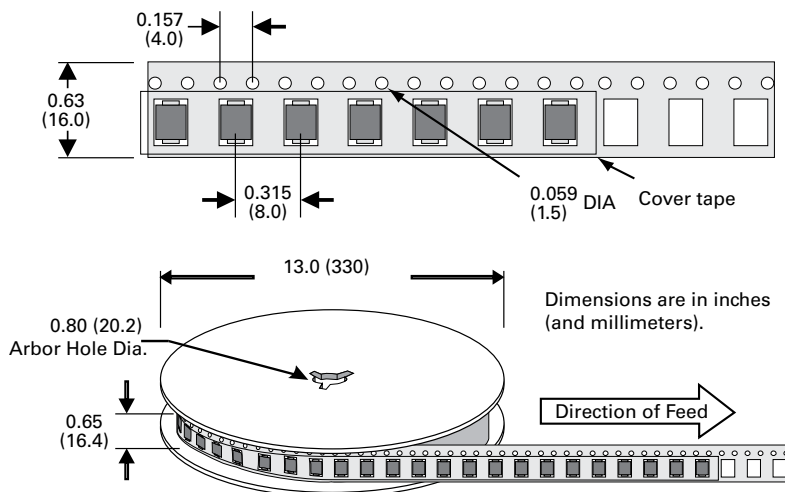

**Disclaimer Notice** - Information furnished is believed to be accurate and reliable. However, users should independently evaluate the suitability of and test each product selected for their own applications. Littelfuse products are not designed for, and may not be used in, all applications. Read complete Disclaimer Notice at <http://www.littelfuse.com/disclaimer-electronics>.