

FC09B1606NL

Flip Chip N/P/N Zener Die, 9V Bi-directional for ESD Protection

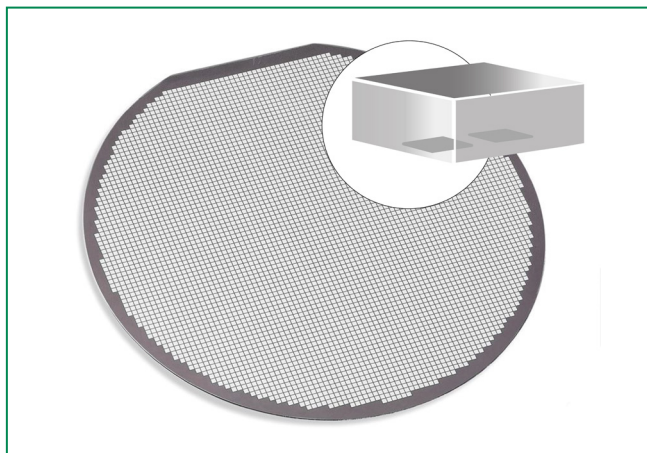

Absolute Maximum Ratings

Symbol	Parameter	Value	Units
T_j	Operating Temperature	150	°C

Part Numbering

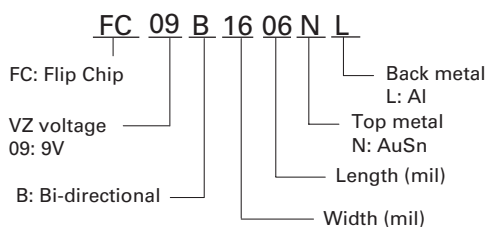

Description

The new FC09B1606NL is for use in LED designs and sensitive elements that require bi-directional ESD protection. The FC09B1606NL meets IEC 61000-4-2, Contact 8 kV.

Features

- Bi-directional
- Paralleled to the LED
- Two way Zener diode protection
- Dual pad metal
- ESD, ± 8 kV contact discharge per IEC 61000-4-2

Applications

- Handset Flash LED ESD protection
- Auto LED headlight ESD
- Backlight LED in Display TV and Monitor
- Outdoor LED
- Ultraviolet UV light / Sterilamp
- Module embedded ESD die for I/Os

Functional Diagram

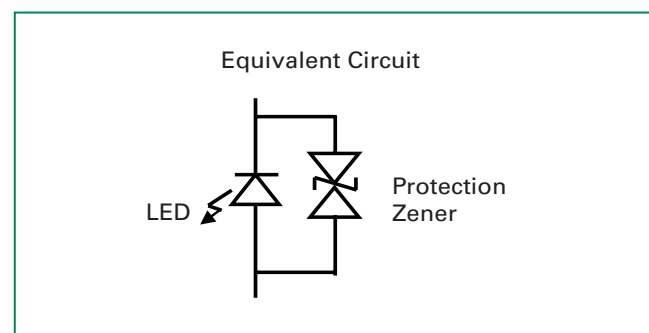

Electrical Characteristics ($T_{OP}=25\text{ }^{\circ}\text{C}$)

Parameter	Symbol	Test Conditions	Min	Typ	Max	Units
Zener Voltage	V_z 1 (Forward)	$I_{zf1}=5\text{ mA}$	7.0		10.5	V
	V_z 2 (Forward)	$I_{zf2}=10\text{ }\mu\text{A}$	7.0		10.5	
		V_z 1 (Forward)	$I_{zf1}=5\text{ mA}$	7.0		10.5
Leakage Current	I_{df}	$V=5\text{ V}$		10	500	nA
	I_{dr}			10	500	nA

Note1: Parameter is guaranteed by package characterization

FC09B1606NL

Flip Chip N/P/N Zener Die, 9V Bi-directional for ESD Protection

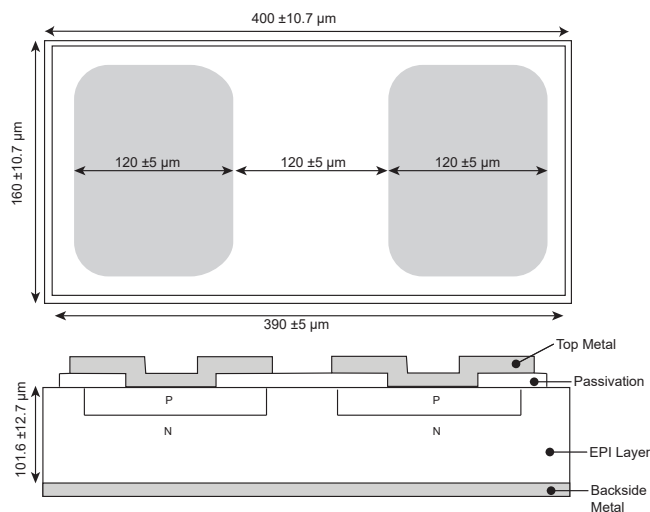
Physical Dimensions

Item	Characteristics	
Die size	400*160 ± 10.7 μm	15.75*6.3 ± 0.42 mil
Pad size	120 ± 5.0 μm	4.72 ± 0.20 mil
Die thickness	101.6 ± 12.7 μm	4.00 ± 0.50 mil
Passivation	390*150 ± 5.0 μm	15.35*5.91 ± 0.20 mil
Top metalization	SnAu 20 / 80 3 μm	SnAu 20 / 80 0.12 mil
Back metallization	Al	

Note:

1. For detail packing specification, please contact with Littelfuse

Disclaimer Notice - Information furnished is believed to be accurate and reliable. However, users should independently evaluate the suitability of and test each product selected for their own applications. Littelfuse products are not designed for, and may not be used in, all applications.

Read complete Disclaimer Notice at <http://www.littelfuse.com/disclaimer-electronics>.