



Expertise Applied | Answers Delivered



# SURGE PROTECTIVE DEVICES CATALOG

**SPD2 SERIES**

**SPDN SERIES**



**SPD2 Series**



**SPDN Series**



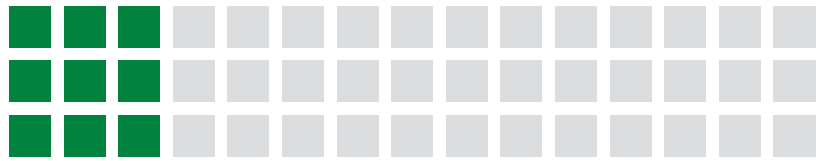

**SPD2 SERIES**

Overview ..... 2

*SPD2 XP+0 SERIES*

SPD2 1P+0 ..... 3  
SPD2 2P+0 ..... 5  
SPD2 3P+0 ..... 7  
SPD2 4P+0 ..... 9

*SPD2 XP+1 SERIES*

SPD2 1P+1 ..... 11  
SPD2 3P+1 ..... 13

*SPD2 PV SERIES*

SPD2 PV ..... 15

SPD2 Series Cross Reference Guide..... 17

**SPDN SERIES**





Overview ..... 18  
SPDN-A..... 19  
SPDN-B..... 21  
SPDN-C..... 23  
SPDN-D ..... 25  
SPDN Series Dimensional Diagrams ..... 27  
SPDN Series Cross Reference Guide ..... 28

# Surge Protective Devices

## SPD2 SERIES OVERVIEW

Littelfuse Type 2 Surge Protection Devices (SPDs) for branch circuits safeguard components from transient overvoltage or surges by limiting the fault current to a load or the unit being protected. Surges may be caused by an indirect lightning strike but, the majority—sixty to eighty percent\*—are caused by equipment being turned on or off within a facility. These surges damage components costing money to repair or replace as well as create unplanned downtime resulting in unfulfilled orders, missed deadlines, unreliable systems and/or dangerous situations.

The DIN-rail mounted SPDs are available in a wide range of operating voltages and include solar applications. They are ideal for:

- |   |   |   |  |
|---|---|---|--|
|  <p><b>Power Distribution</b></p> <ul style="list-style-type: none"> <li>▪ Load Centers</li> <li>▪ Transformers</li> <li>▪ Generators</li> </ul> |  <p><b>Industrial Controls</b></p> <ul style="list-style-type: none"> <li>▪ Programmable Logic Controllers</li> <li>▪ Motor Controls</li> <li>▪ Variable-Frequency Drives</li> <li>▪ Proximity Sensors</li> <li>▪ Barcoding Equipment</li> <li>▪ Machine Vision Systems</li> </ul> |  <p><b>Electrical Loads</b></p> <ul style="list-style-type: none"> <li>▪ Motors</li> <li>▪ Fans</li> <li>▪ Heaters</li> <li>▪ Blowers</li> <li>▪ Ballasts</li> </ul> |  <p><b>Computers and Communications</b></p> <ul style="list-style-type: none"> <li>▪ LANs</li> <li>▪ WANs</li> <li>▪ Intercoms</li> <li>▪ Fire, Security, UPS or Building Management Systems</li> </ul> |
|  <p><b>HVAC or Medical Equipment</b></p>   |   |   |  |

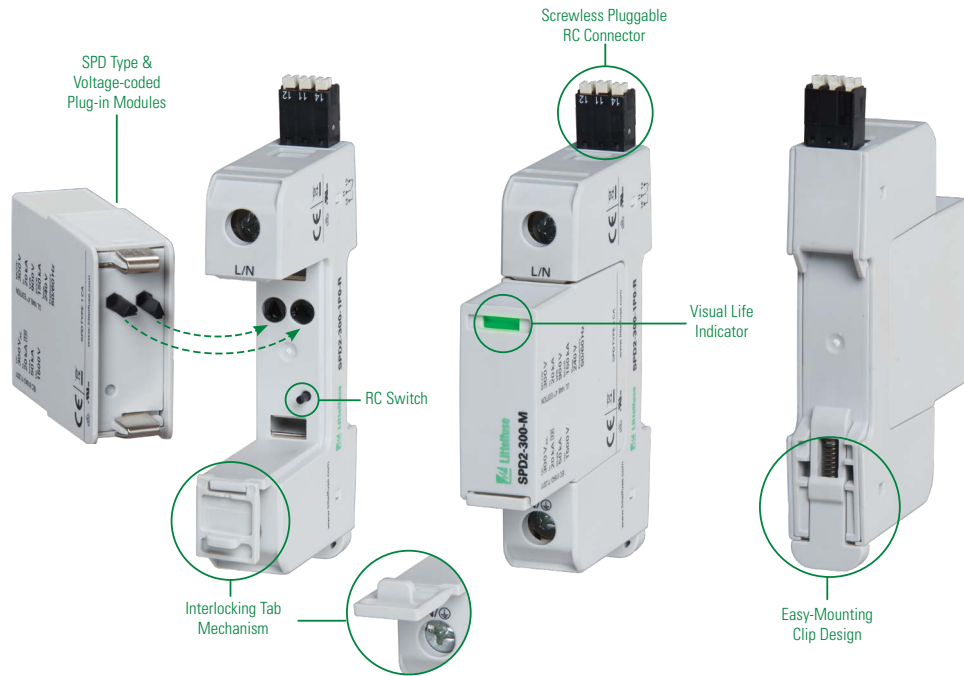

FEATURES	BENEFITS
Capability to clamp and withstand high-energy transients	Ensures low-residual voltage during high-energy surge events and higher nominal discharge current to prevent disruption, downtime, and degradation or damage to equipment
UL and VDE-IEC compliant in single part number	One component can be utilized globally, reducing inventory needs and simplifying allocation of parts
Interlocking tab mechanism	Secures module to withstand vibration
SPD type and voltage-coded plug-in module	Prevents specific SPD/voltage module from being plugged into wrong base. Eliminates risk of improper protection
No additional overcurrent protection devices required in UL applications	Reduces the number of components and costs required for protection
Compact footprint	Increases panel design flexibility
Visual life indicator	Quick visual determines module replacement status to avoid loss of protection
Pluggable modules	Fast and simple to replace, minimizing maintenance and downtime. No tools required
Thermal protection	Eliminates catastrophic failure
IP20 protection rating	Finger-safe design increases worker protection

\*National Electrical Safety Month 2015, Electrical Safety Foundation International [website] Surge and Protect. Available: <https://www.esfi.org/resource/surge-and-protect-413>

# Surge Protective Devices

## SPD2 1P+0 SERIES

### Class II/Type 2/Type 1 CA Pluggable Single-Pole



### Internal Configuration

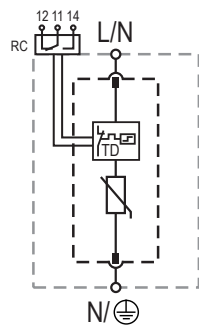

#### Legend

- L Line
- N Neutral
- ⊕ Protective Earth
- RC Remote Contacts
- TD Thermal Disconnection

### Description

Surge protection devices (SPDs) provide equipment protection from transient overvoltage events lasting micro-seconds. By limiting the overvoltage to the equipment during these events, costly damage and downtime can be mitigated.

The surge protection devices for the 1+0 configuration are available for 60 V to 600 V nominal voltage sub-distribution board applications.

### Features & Benefits

FEATURES	BENEFITS
<b>Capability to clamp and withstand high-energy transients</b>	Ensures low-residual voltage during high-energy surge events and higher nominal discharge current to prevent disruption, downtime, and degradation or damage to equipment
<b>UL and VDE-IEC compliant in single part number</b>	One component can be utilized globally, reducing inventory needs and simplifying allocation of parts
<b>Interlocking tab mechanism</b>	Secures module to withstand vibration
<b>No additional overcurrent protection devices required in UL applications</b>	Reduces the number of components and costs required for protection
<b>Compact footprint</b>	Increases panel design flexibility
<b>Visual life indicator</b>	Quick visual determines module replacement status to avoid loss of protection
<b>Pluggable modules</b>	Fast and simple to replace, minimizing maintenance and downtime. No tools required
<b>Thermal protection</b>	Eliminates catastrophic failure
<b>IP20 protection rating</b>	Finger-safe design increases worker protection

### Module & Base Ordering Information

Ordering Number	IEC Electrical								UL Electrical				Single Unit Weight
	Nominal AC Voltage (50/60 Hz) ( $U_n$ )	Maximum Continuous Operating AC Voltage ( $U_c$ )	Nominal Discharge Current (8/20 $\mu$ s) ( $I_n$ )	Maximum Discharge Current (8/20 $\mu$ s) ( $I_{max}$ )	Voltage Protection Level ( $U_p$ )	Short-Circuit AC Current Rating ( $I_{SCCR}$ )	TOV Withstand 5 s ( $U_1$ )	TOV 120 min ( $U_1$ ) / Mode	Maximum Continuous AC Operating Voltage (MCOV)	Voltage Protection Rating (VPR)	Nominal Discharge Current (8/20 $\mu$ s) ( $I_n$ )	Short-Circuit Current Rating (SCCR)	
SPD2-075-1P0-R	60 V	75 V	20 kA	50 kA	800 V	25 kA / 50 kA	114 V	114 V / Withstand	75 V	330 V	20 kA	100 kA	124 g (0.274 lb)
SPD2-150-1P0-R	120 V	150 V	20 kA	50 kA	1250 V	25 kA / 50 kA	229 V	229 V / Withstand	150 V	600 V	20 kA	200 kA	128 g (0.283 lb)
SPD2-300-1P0-R	240 V	300 V	20 kA	50 kA	1500 V	25 kA / 50 kA	337 V	442 V / Safe Fail	300 V	900 V	20 kA	150 kA	135 g (0.298 lb)
SPD2-350-1P0-R	277 V	350 V	20 kA	50 kA	1750 V	25 kA / 50 kA	403 V	529 V / Safe Fail	350 V	1000 V	20 kA	200 kA	140 g (0.309 lb)
SPD2-480-1P0-R	400 V	480 V	20 kA	50 kA	2300 V	25 kA / 50 kA	581 V	762 V / Safe Fail	480 V	1500 V	20 kA	200 kA	145 g (0.320 lb)
SPD2-550-1P0-R*	480 V	550 V	20 kA	50 kA	2500 V	25 kA / 50 kA	697 V	915 V / Safe Fail	550 V	2000 V	20 kA	200 kA	148 g (0.326 lb)
SPD2-750-1P0-R	600 V	750 V	20 kA	35 kA	3400 V	25 kA / 50 kA	871 V	1143 V / Safe Fail	750 V	2500 V	20 kA	200 kA	161 g (0.355 lb)

# Surge Protective Devices

## SPD2 1P+0 SERIES

### Module & Base Part Numbering System



### Module Only Part Numbering System



### Replacement Module Ordering Information

Ordering Number	IEC Electrical								UL Electrical				Single Unit Weight
	Nominal AC Voltage (50/60 Hz) ( $U_n$ )	Maximum Continuous Operating AC Voltage ( $U_c$ )	Nominal Discharge Current (8/20 $\mu$ s) ( $I_n$ )	Maximum Discharge Current (8/20 $\mu$ s) ( $I_{max}$ )	Voltage Protection Level ( $U_p$ )	Short-Circuit AC Current Rating ( $I_{scCR}$ )	TOV Withstand 5 s ( $U_T$ )	TOV 120 min ( $U_T$ ) / Mode	Maximum Continuous AC Operating Voltage (MCOV)	Voltage Protection Rating (VPR)	Nominal Discharge Current (8/20 $\mu$ s) ( $I_n$ )	Short-Circuit Current Rating (SCCR)	
SPD2-075-M	60 V	75 V	20 kA	50 kA	800 V	25 kA / 50 kA	114 V	114 V / Withstand	75 V	330 V	20 kA	100 kA	50 g (0.111 lb)
SPD2-150-M	120 V	150 V	20 kA	50 kA	1250 V	25 kA / 50 kA	229 V	229 V / Withstand	150 V	600 V	20 kA	200 kA	54 g (0.120 lb)
SPD2-300-M	240 V	300 V	20 kA	50 kA	1500 V	25 kA / 50 kA	337 V	442 V / Safe Fail	300 V	900 V	20 kA	150 kA	61 g (0.135 lb)
SPD2-350-M	277 V	350 V	20 kA	50 kA	1750 V	25 kA / 50 kA	403 V	529 V / Safe Fail	350 V	1000 V	20 kA	200 kA	66 g (0.146 lb)
SPD2-480-M	400 V	480 V	20 kA	50 kA	2300 V	25 kA / 50 kA	581 V	762 V / Safe Fail	480 V	1500 V	20 kA	200 kA	71 g (0.157 lb)
SPD2-550-M*	480 V	550 V	20 kA	50 kA	2500 V	25 kA / 50 kA	697 V	915 V / Safe Fail	550 V	2000 V	20 kA	200 kA	74 g (0.163 lb)
SPD2-750-M	600 V	750 V	20 kA	35 kA	3400 V	25 kA / 50 kA	871 V	1143 V / Safe Fail	750 V	2500 V	20 kA	200 kA	87 g (0.192 lb)

### Specifications

<b>Network Systems</b>	TN-S, TN-C, TT (only L-N)
<b>Mode of Protection</b>	L-PE, N-PE (only TN-S), L-PEN, L-N
<b>Nominal Discharge Current (8/20 <math>\mu</math>s) (<math>I_n</math>)</b>	20 kA
<b>Maximum Discharge Current (8/20 <math>\mu</math>s) (<math>I_{max}</math>)</b>	Up to 50 kA
<b>Protective Elements</b>	High Energy MOV
<b>Response Time (L-N / N-PE <math>t_A</math>)</b>	< 25 ns
<b>Back-Up Fuse (max)</b>	315 A/250 A Gg
<b>Number of Ports</b>	1
<b>Mechanical &amp; Environmental</b>	
<b>Operating Temperature Range (<math>T_a</math>)</b>	-40 °C to +80 °C (-40 °F to +185 °F)
<b>Permissible Operating Humidity (RH)</b>	5% to 95%
<b>Altitude (max)</b>	4,000 m (13,123 ft)
<b>Terminal Screw Torque (<math>M_{max}</math>)</b>	4.5 Nm (39.9 lbf-in)
<b>Conductor Cross Section (max)</b>	35 mm <sup>2</sup> (2 AWG) (Solid, Stranded)/ 25 mm <sup>2</sup> (4 AWG) (Flexible)
<b>Mounting</b>	35 mm DIN Rail, EN60715
<b>Degree of Protection</b>	IP20 (built-in)
<b>Housing Material</b>	Thermoplastic: Extinguishing Degree UL 94 V-0

<b>Thermal Protection</b>	Yes
<b>Operating State/Fault Indication</b>	Green Flag/No Green Flag
<b>Remote Contact Switching Capacity</b>	AC: 250 V/1 A, 125 V/1 A; DC: 48 V/0.5 A, 24 V/0.5 A, 12 V/0.5 A
<b>Remote Contact Conductor Cross Section (max)</b>	1.5 mm <sup>2</sup> (16 AWG) (Solid)
<b>Standards Passed*</b>	IEC 61643-11:2011 EN 61643-11:2012 UL 1449, 4th edition

<b>Product Dimensions</b>	
<b>1TE Module and Base</b>	<b>H</b> 90.0 mm (3.54"); <b>W</b> 18.0 mm (0.71"); <b>D</b> 70.0 mm (2.76")
<b>1TE Replacement Module</b>	<b>H</b> 45.0 mm (1.77"); <b>W</b> 18.0 mm (0.71"); <b>D</b> 57.2mm (2.25")
<b>Package Dimensions</b>	
<b>1TE Module and Base</b>	<b>H</b> 102.0 mm (4.01"); <b>W</b> 28.0 mm (1.10"); <b>D</b> 110.0 mm (4.33")
<b>1TE Replacement Module</b>	<b>H</b> 102.0 mm (4.01"); <b>W</b> 28.0 mm (1.10"); <b>D</b> 110.0 mm (4.33")

\*SPD2-550-1P0-R and SPD2-550-M are UL Listed only

Warranty – Visit [www.littelfuse.com/warranty](http://www.littelfuse.com/warranty) for details.

# Surge Protective Devices

## SPD2 2P+0 SERIES

### Class II/Type 2/Type 1 CA Pluggable Multi-Pole

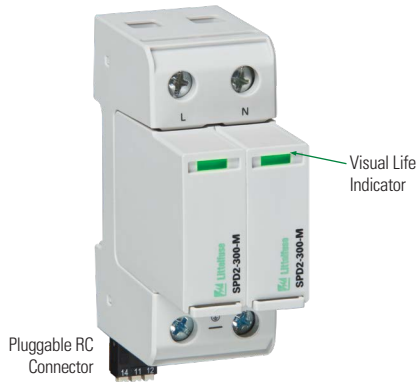

### Description

Surge protection devices (SPDs) provide equipment protection from transient overvoltage events lasting micro-seconds. By limiting the overvoltage to the equipment during these events, costly damage and downtime can be mitigated.

The surge protection devices for the 2+0 configuration are available for 120 V to 600 V nominal voltage sub-distribution board applications.

### Features & Benefits

FEATURES	BENEFITS
<b>Capability to clamp and withstand high-energy transients</b>	Ensures low-residual voltage during high-energy surge events and higher nominal discharge current to prevent disruption, downtime, and degradation or damage to equipment
<b>UL and VDE-IEC compliant in single part number</b>	One component can be utilized globally, reducing inventory needs and simplifying allocation of parts
<b>Interlocking tab mechanism</b>	Secures module to withstand vibration
<b>No additional overcurrent protection devices required in UL applications</b>	Reduces the number of components and costs required for protection
<b>Compact footprint</b>	Increases panel design flexibility
<b>Visual life indicator</b>	Quick visual determines module replacement status to avoid loss of protection
<b>Pluggable modules</b>	Fast and simple to replace, minimizing maintenance and downtime. No tools required
<b>Thermal protection</b>	Eliminates catastrophic failure
<b>IP20 protection rating</b>	Finger-safe design increases worker protection

### Internal Configuration

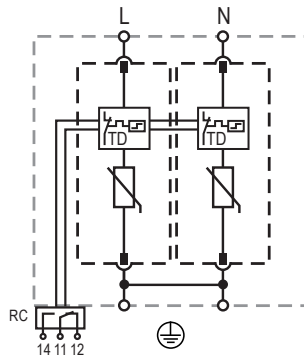

### Legend

- L Line
- N Neutral
- ⊕ Protective Earth
- RC Remote Contacts
- TD Thermal Disconnection

### Module & Base Ordering Information

Ordering Number	IEC Electrical								UL Electrical				Single Unit Weight
	Nominal AC Voltage (150/60Hz) ( $U_n/U_1$ )	Maximum Continuous Operating AC Voltage ( $U_c$ )	Nominal Discharge Current (8/20 $\mu$ s) ( $I_n$ )	Maximum Discharge Current (8/20 $\mu$ s) ( $I_{max}$ )	Voltage Protection Level ( $U_p$ )	Short-Circuit AC Current Rating ( $I_{SCR}$ )	TOV Withstand 5 s ( $U_1$ )	TOV 120 min ( $U_1$ ) / Mode	Maximum Continuous AC Operating Voltage (MCOV)	Voltage Protection Rating (VPR)	Nominal Discharge Current (8/20 $\mu$ s) ( $I_n$ )	Short-Circuit Current Rating (ISCCR)	
SPD2-150-2P0-R	120 V	150 V	20 kA	50 kA	1250 V	25 kA / 50 kA	229 V	229 V / Withstand	150 V	600 V	20 kA	200 kA	252 g (0.556 lb)
SPD2-300-2P0-R	240 V	300 V	20 kA	50 kA	1500 V	25 kA / 50 kA	337 V	442 V / Safe Fail	300 V	900 V	20 kA	150 kA	266 g (0.587 lb)
SPD2-350-2P0-R	277 V	350 V	20 kA	50 kA	1750 V	25 kA / 50 kA	403 V	529 V / Safe Fail	350 V	1000 V	20 kA	200 kA	276 g (0.609 lb)
SPD2-480-2P0-R	400 V	480 V	20 kA	50 kA	2300 V	25 kA / 50 kA	581 V	762 V / Safe Fail	480 V	1500 V	20 kA	200 kA	286 g (0.631 lb)
SPD2-550-2P0-R*	480 V	550 V	20 kA	50 kA	2500 V	25 kA / 50 kA	697 V	915 V / Safe Fail	550 V	2000 V	20 kA	200 kA	290 g (0.639 lb)
SPD2-750-2P0-R	600 V	750 V	20 kA	35 kA	3400 V	25 kA / 50 kA	871 V	1143 V / Safe Fail	750 V	2500 V	20 kA	200 kA	318 g (0.702 lb)

# Surge Protective Devices

## SPD2 2P+0 SERIES

### Module & Base Part Numbering System



### Module Only Part Numbering System



### Replacement Module Ordering Information

Ordering Number	IEC Electrical								UL Electrical				Single Unit Weight
	Nominal AC Voltage (50/60Hz) ( $U_n$ )	Maximum Continuous Operating AC Voltage ( $U_c$ )	Nominal Discharge Current (8/20 $\mu$ s) ( $I_n$ )	Maximum Discharge Current (8/20 $\mu$ s) ( $I_{max}$ )	Voltage Protection Level ( $U_p$ )	Short-Circuit AC Current Rating ( $I_{scCR}$ )	TOV Withstand 5 s ( $U_1$ )	TOV 120 min ( $U_1$ ) / Mode	Maximum Continuous AC Operating Voltage (MCOV)	Voltage Protection Rating (VPR)	Nominal Discharge Current (8/20 $\mu$ s) ( $I_n$ )	Short-Circuit Current Rating (SCCR)	
SPD2-150-M	120 V	150 V	20 kA	50 kA	1250 V	25 kA / 50 kA	229 V	229 V / Withstand	150 V	600 V	20 kA	200 kA	54 g (0.120 lb)
SPD2-300-M	240 V	300 V	20 kA	50 kA	1500 V	25 kA / 50 kA	337 V	442 V / Safe Fail	300 V	900 V	20 kA	150 kA	61 g (0.135 lb)
SPD2-350-M	277 V	350 V	20 kA	50 kA	1750 V	25 kA / 50 kA	403 V	529 V / Safe Fail	350 V	1000 V	20 kA	200 kA	66 g (0.146 lb)
SPD2-480-M	400 V	480 V	20 kA	50 kA	2300 V	25 kA / 50 kA	581 V	762 V / Safe Fail	480 V	1500 V	20 kA	200 kA	71 g (0.157 lb)
SPD2-550-M*	480 V	550 V	20 kA	50 kA	2500 V	25 kA / 50 kA	697 V	915 V / Safe Fail	550 V	2000 V	20 kA	200 kA	74 g (0.163 lb)
SPD2-750-M	600 V	750 V	20 kA	35 kA	3400 V	25 kA / 50 kA	871 V	1143 V / Safe Fail	750 V	2500 V	20 kA	200 kA	87 g (0.192 lb)

### Specifications

<b>Network Systems</b>	TN-S
<b>Mode of Protection</b>	L-PE, N-PE
<b>Nominal Discharge Current (8/20 <math>\mu</math>s) (<math>I_n</math>)</b>	20 kA
<b>Maximum Discharge Current (8/20 <math>\mu</math>s) (<math>I_{max}</math>)</b>	Up to 50 kA
<b>Protective Elements</b>	High Energy MOV
<b>Response Time (<math>t_A</math>)</b>	< 25 ns
<b>Back-Up Fuse (max)</b>	315 A/250 A Gg
<b>Number of Ports</b>	1
<b>Mechanical &amp; Environmental</b>	
<b>Operating Temperature Range (<math>T_o</math>)</b>	-40 °C to +80 °C (-40 °F to +185 °F)
<b>Permissible Operating Humidity (RH)</b>	5% to 95%
<b>Altitude (max)</b>	4,000 m (13,123 ft)
<b>Terminal Screw Torque (<math>M_{max}</math>)</b>	4.5 Nm (39.9 lbf-in)
<b>Conductor Cross Section (max)</b>	35 mm <sup>2</sup> (2 AWG) (Solid, Stranded)/ 25 mm <sup>2</sup> (4 AWG) (Flexible)
<b>Mounting</b>	35 mm DIN Rail, EN60715
<b>Degree of Protection</b>	IP20 (built-in)
<b>Housing Material</b>	Thermoplastic: Extinguishing Degree UL 94 V-0
<b>Thermal Protection</b>	Yes

<b>Operating State/Fault Indication</b>	Green Flag/No Green Flag
<b>Remote Contact Switching Capacity</b>	AC: 250 V/1 A, 125 V/1 A; DC: 48 V/0.5 A, 24 V/0.5 A, 12 V/0.5 A
<b>Remote Contact Conductor Cross Section (max)</b>	1.5 mm <sup>2</sup> (16 AWG) (Solid)
<b>Standards Passed*</b>	IEC 61643-11:2011 EN 61643-11:2012 UL 1449, 4th edition
<b>Dimensions &amp; Packaging</b>	
<b>2TE Module and Base</b>	<b>H</b> 90.0 mm (3.54"); <b>W</b> 36.0 mm (1.42"); <b>D</b> 70.0 mm (2.76")
<b>1TE Replacement Module</b>	<b>H</b> 45.0 mm (1.77"); <b>W</b> 18.0 mm (0.71"); <b>D</b> 57.2mm (2.25")
<b>Package Dimensions</b>	
<b>2TE Module and Base</b>	<b>H</b> 102.0 mm (4.01"); <b>W</b> 46.0 mm (1.81"); <b>D</b> 110.0 mm (4.33")
<b>1TE Replacement Module</b>	<b>H</b> 102.0 mm (4.01"); <b>W</b> 28.0 mm (1.10"); <b>D</b> 110.0 mm (4.33")

\*SPD2-550-2P0-R and SPD2-550-M are UL Listed only

Warranty – Visit [www.littelfuse.com/warranty](http://www.littelfuse.com/warranty) for details.



# Surge Protective Devices

## SPD2 3P+0 SERIES

### Class II/Type 2/Type 1 CA Pluggable Multi-Pole



### Description

Surge protection devices (SPDs) provide equipment protection from transient overvoltage events lasting micro-seconds. By limiting the overvoltage to the equipment during these events, costly damage and downtime can be mitigated.

The surge protection devices for the 3+0 configuration are available for 120 V to 600 V nominal voltage sub-distribution board applications.

### Features & Benefits

FEATURES	BENEFITS
<b>Capability to clamp and withstand high-energy transients</b>	Ensures low-residual voltage during high-energy surge events and higher nominal discharge current to prevent disruption, downtime, and degradation or damage to equipment
<b>UL and VDE-IEC compliant in single part number</b>	One component can be utilized globally, reducing inventory needs and simplifying allocation of parts
<b>Interlocking tab mechanism</b>	Secures module to withstand vibration
<b>No additional overcurrent protection devices required in UL applications</b>	Reduces the number of components and costs required for protection
<b>Compact footprint</b>	Increases panel design flexibility
<b>Visual life indicator</b>	Quick visual determines module replacement status to avoid loss of protection
<b>Pluggable modules</b>	Fast and simple to replace, minimizing maintenance and downtime. No tools required
<b>Thermal protection</b>	Eliminates catastrophic failure
<b>IP20 protection rating</b>	Finger-safe design increases worker protection

### Internal Configuration

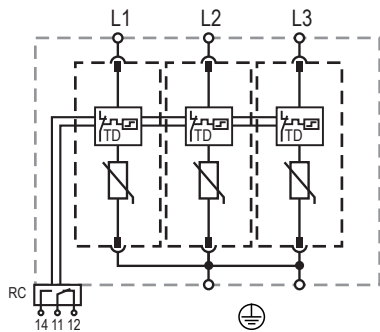

### Legend

- L Line
- N Neutral
- ⊕ Protective Earth
- RC Remote Contacts
- TD Thermal Disconnection

### Module & Base Ordering Information

Ordering Number	IEC Electrical							UL Electrical				Single Unit Weight	
	Nominal AC Voltage (50/60Hz) ( $U_n/U_c$ )	Maximum Continuous Operating AC Voltage ( $U_c$ )	Nominal Discharge Current (8/20 $\mu$ s) ( $I_n$ )	Maximum Discharge Current (8/20 $\mu$ s) ( $I_{max}$ )	Voltage Protection Level ( $U_p$ )	Short-Circuit AC Current Rating ( $I_{scpr}$ )	TOV Withstand 5 s ( $U_1$ )	TOV 120 min ( $U_1$ ) / Mode	Maximum Continuous AC Operating Voltage (MCOV)	Voltage Protection Rating (VPR)	Nominal Discharge Current (8/20 $\mu$ s) ( $I_n$ )		Short-Circuit Current Rating (SCCR)
SPD2-150-3P0-R	120 V	150 V	20 kA	50 kA	1250 V	25 kA / 50 kA	229 V	229 V / Withstand	150 V	600 V	20 kA	200 kA	355 g (0.783 lb)
SPD2-300-3P0-R	240 V	300 V	20 kA	50 kA	1500 V	25 kA / 50 kA	337 V	442 V / Safe Fail	300 V	900 V	20 kA	150 kA	376 g (0.829 lb)
SPD2-350-3P0-R	277 V	350 V	20 kA	50 kA	1750 V	25 kA / 50 kA	403 V	529 V / Safe Fail	350 V	1000 V	20 kA	200 kA	391 g (0.862 lb)
SPD2-480-3P0-R	400 V	480 V	20 kA	50 kA	2300 V	25 kA / 50 kA	581 V	762 V / Safe Fail	480 V	1500 V	20 kA	200 kA	406 g (0.896 lb)
SPD2-550-3P0-R*	480 V	550 V	20 kA	50 kA	2500 V	25 kA / 50 kA	697 V	915 V / Safe Fail	550 V	2000 V	20 kA	200 kA	414 g (0.913 lb)
SPD2-750-3P0-R	600 V	750 V	20 kA	35 kA	3400 V	25 kA / 50 kA	871 V	1143 V / Safe Fail	750 V	2500 V	20 kA	200 kA	454 g (1.001 lb)

# Surge Protective Devices

## SPD2 3P+0 SERIES

### Module & Base Part Numbering System



### Module Only Part Numbering System

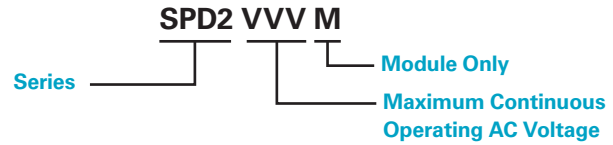

### Replacement Module Ordering Information

Ordering Number	IEC Electrical							UL Electrical					Single Unit Weight
	Nominal AC Voltage (60/60Hz) ( $U_n/U_c$ )	Maximum Continuous Operating AC Voltage ( $U_c$ )	Nominal Discharge Current (8/20 $\mu$ s) ( $I_n$ )	Maximum Discharge Current (8/20 $\mu$ s) ( $I_{max}$ )	Voltage Protection Level ( $U_p$ )	Short-Circuit AC Current Rating ( $I_{scch}$ )	TOV Withstand 5 s ( $U_t$ )	TOV TOV 120 min ( $U_t$ / Mode)	Maximum Continuous AC Operating Voltage (MCOV)	Voltage Protection Rating (VPR)	Nominal Discharge Current (8/20 $\mu$ s) ( $I_n$ )	Short-Circuit Current Rating (SCCR)	
SPD2-150-M	120 V	150 V	20 kA	50 kA	1250 V	25 kA / 50 kA	229 V	229 V / Withstand	150 V	600 V	20 kA	200 kA	54 g (0.120 lb)
SPD2-300-M	240 V	300 V	20 kA	50 kA	1500 V	25 kA / 50 kA	337 V	442 V / Safe Fail	300 V	900 V	20 kA	150 kA	61 g (0.135 lb)
SPD2-350-M	277 V	350 V	20 kA	50 kA	1750 V	25 kA / 50 kA	403 V	529 V / Safe Fail	350 V	1000 V	20 kA	200 kA	66 g (0.146 lb)
SPD2-480-M	400 V	480 V	20 kA	50 kA	2300 V	25 kA / 50 kA	581 V	762 V / Safe Fail	480 V	1500 V	20 kA	200 kA	71 g (0.157 lb)
SPD2-550-M*	480 V	550 V	20 kA	50 kA	2500 V	25 kA / 50 kA	697 V	915 V / Safe Fail	550 V	2000 V	20 kA	200 kA	74 g (0.163 lb)
SPD2-750-M	600 V	750 V	20 kA	35 kA	3400 V	25 kA / 50 kA	871 V	1143 V / Safe Fail	750 V	2500 V	20 kA	200 kA	87 g (0.192 lb)

### Specifications

<b>Network Systems</b>	TT, TN-S
<b>Mode of Protection</b>	L-N, N-PE
<b>Nominal Discharge Current (8/20 <math>\mu</math>s) (<math>I_n</math>)</b>	20 kA
<b>Maximum Discharge Current (8/20 <math>\mu</math>s) (<math>I_{max}</math>)</b>	Up to 50 kA
<b>Protective Elements</b>	High Energy MOV
<b>Response Time (L-N / N-PE <math>t_A</math>)</b>	< 25 ns
<b>Back-Up Fuse (max)</b>	315 A/250 A Gg
<b>Number of Ports</b>	1
<b>Mechanical &amp; Environmental</b>	
<b>Operating Temperature Range (<math>T_o</math>)</b>	-40 °C to +80 °C (-40 °F to +185 °F)
<b>Permissible Operating Humidity (RH)</b>	5% to 95%
<b>Altitude (max)</b>	4,000 m (13,123 ft)
<b>Terminal Screw Torque (<math>M_{max}</math>)</b>	4.5 Nm (39.9 lbf-in)
<b>Conductor Cross Section (max)</b>	35 mm <sup>2</sup> (2 AWG) (Solid, Stranded)/ 25 mm <sup>2</sup> (4 AWG) (Flexible)
<b>Mounting</b>	35 mm DIN Rail, EN60715
<b>Degree of Protection</b>	IP20 (built-in)
<b>Housing Material</b>	Thermoplastic: Extinguishing Degree UL 94 V-0

<b>Thermal Protection</b>	Yes
<b>Operating State/Fault Indication</b>	Green Flag/No Green Flag
<b>Remote Contact Switching Capacity</b>	AC: 250 V/1 A, 125 V/1 A; DC: 48 V/0.5 A, 24 V/0.5 A, 12 V/0.5 A
<b>Remote Contact Conductor Cross Section (max)</b>	1.5 mm <sup>2</sup> (16 AWG) (Solid)
<b>Standards Passed*</b>	IEC 61643-11:2011 EN 61643-11:2012 UL 1449, 4th edition

<b>Product Dimensions</b>	
<b>3TE Module and Base</b>	<b>H</b> 90.0 mm (3.54"); <b>W</b> 54.0 mm (2.13"); <b>D</b> 70.0 mm (2.76")
<b>1TE Replacement Module</b>	<b>H</b> 45.0 mm (1.77"); <b>W</b> 18.0 mm (0.71"); <b>D</b> 57.2mm (2.25")
<b>Package Dimensions</b>	
<b>3TE Module and Base</b>	<b>H</b> 102.0 mm (4.01"); <b>W</b> 64.0 mm (2.52"); <b>D</b> 110.0 mm (4.33")
<b>1TE Replacement Module</b>	<b>H</b> 102.0 mm (4.01"); <b>W</b> 28.0 mm (1.10"); <b>D</b> 110.0 mm (4.33")

\*SPD2-550-3P0-R and SPD2-550-M are UL Listed only

Warranty – Visit [www.littelfuse.com/warranty](http://www.littelfuse.com/warranty) for details.

# Surge Protective Devices

## SPD2 4P+0 SERIES

### Class II/Type 2/Type 1 CA Pluggable Multi-Pole



### Description

Surge protection devices (SPDs) provide equipment protection from transient overvoltage events lasting micro-seconds. By limiting the overvoltage to the equipment during these events, costly damage and downtime can be mitigated.

The surge protection devices for the 4+0 configuration are available for 120 V to 480 V nominal voltage sub-distribution board applications.

### Features & Benefits

FEATURES	BENEFITS
<b>Capability to clamp and withstand high-energy transients</b>	Ensures low-residual voltage during high-energy surge events and higher nominal discharge current to prevent disruption, downtime, and degradation or damage to equipment
<b>UL and VDE-IEC compliant in single part number</b>	One component can be utilized globally, reducing inventory needs and simplifying allocation of parts
<b>Interlocking tab mechanism</b>	Secures module to withstand vibration
<b>No additional overcurrent protection devices required in UL applications</b>	Reduces the number of components and costs required for protection
<b>Compact footprint</b>	Increases panel design flexibility
<b>Visual life indicator</b>	Quick visual determines module replacement status to avoid loss of protection
<b>Pluggable modules</b>	Fast and simple to replace, minimizing maintenance and downtime. No tools required
<b>Thermal protection</b>	Eliminates catastrophic failure
<b>IP20 protection rating</b>	Finger-safe design increases worker protection

### Internal Configuration

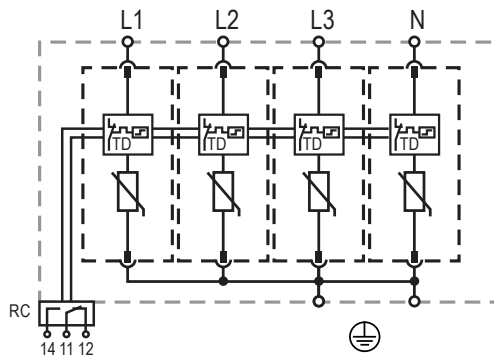

### Legend

- L Line
- N Neutral
- ⊕ Protective Earth
- RC Remote Contacts
- TD Thermal Disconnection

### Module & Base Ordering Information

Ordering Number	IEC Electrical								UL Electrical				Single Unit Weight
	Nominal AC Voltage (50/60Hz) ( $U_n$ ) ( $U_c$ )	Maximum Continuous Operating AC Voltage ( $U_c$ )	Nominal Discharge Current (8/20 $\mu$ s) ( $I_n$ )	Maximum Discharge Current (8/20 $\mu$ s) ( $I_{max}$ )	Voltage Protection Level ( $U_p$ )	Short-Circuit AC Current Rating ( $I_{sc(IEC)}$ )	TOV Withstand 5 s ( $U_s$ )	TOV 120 min ( $U_r$ ) / Mode	Maximum AC Continuous Operating Voltage (MCOV)	Voltage Protection Rating (VPR)	Nominal Discharge Current (8/20 $\mu$ s) ( $I_n$ )	Short-Circuit Current Rating (SCCR)	
SPD2-150-4P0-R	120 V	150 V	20 kA	50 kA	1250 V	25 kA / 50 kA	229 V	229 V / Withstand	150 V	600 V	20 kA	200 kA	477 g (1.052 lb)
SPD2-300-4P0-R	240 V	300 V	20 kA	50 kA	1500 V	25 kA / 50 kA	337 V	442 V / Safe Fail	300 V	900 V	20 kA	150 kA	505 g (1.114 lb)
SPD2-350-4P0-R	277 V	350 V	20 kA	50 kA	1750 V	25 kA / 50 kA	403 V	529 V / Safe Fail	350 V	1000 V	20 kA	200 kA	525 g (1.158 lb)
SPD2-480-4P0-R	400 V	480 V	20 kA	50 kA	2300 V	25 kA / 50 kA	581 V	762 V / Safe Fail	480 V	1500 V	20 kA	200 kA	545 g (1.202 lb)
SPD2-550-4P0-R*	480 V	550 V	20 kA	50 kA	2500 V	25 kA / 50 kA	697 V	915 V / Safe Fail	550 V	2000 V	20 kA	200 kA	557 g (1.228 lb)

# Surge Protective Devices

## SPD2 4P+0 SERIES

### Module & Base Part Numbering System



### Module Only Part Numbering System

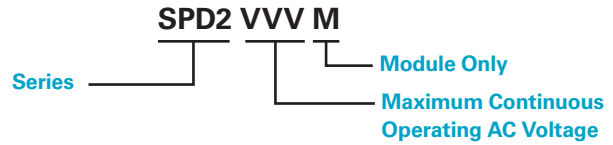

### Replacement Module Ordering Information

Ordering Number	IEC Electrical								UL Electrical				Single Unit Weight
	Nominal AC Voltage (50/60Hz) ( $U_n$ )	Maximum Continuous Operating AC Voltage ( $U_c$ )	Nominal Discharge Current (8/20 $\mu$ s) ( $I_n$ )	Maximum Discharge Current (8/20 $\mu$ s) ( $I_{max}$ )	Voltage Protection Level ( $U_p$ )	Short-Circuit AC Current Rating ( $I_{SCCR}$ )	TOV Withstand 5 s ( $U_t$ )	TOV 120 min ( $U_t$ ) / Mode	Maximum Continuous AC Operating Voltage (MCOV)	Voltage Protection Rating (VPR)	Nominal Discharge Current (8/20 $\mu$ s) ( $I_n$ )	Short-Circuit Current Rating (SCCR)	
SPD2-150-M	120 V	150 V	20 kA	50 kA	1250 V	25 kA / 50 kA	229 V	229 V / Withstand	150 V	600 V	20 kA	200 kA	54 g (0.120 lb)
SPD2-300-M	240 V	300 V	20 kA	50 kA	1500 V	25 kA / 50 kA	337 V	442 V / Safe Fail	300 V	900 V	20 kA	150 kA	61 g (0.135 lb)
SPD2-350-M	277 V	350 V	20 kA	50 kA	1750 V	25 kA / 50 kA	403 V	529 V / Safe Fail	350 V	1000 V	20 kA	200 kA	66 g (0.146 lb)
SPD2-480-M	400 V	480 V	20 kA	50 kA	2300 V	25 kA / 50 kA	581 V	762 V / Safe Fail	480 V	1500 V	20 kA	200 kA	71 g (0.157 lb)
SPD2-550-M*	480 V	550 V	20 kA	50 kA	2500 V	25 kA / 50 kA	697 V	915 V / Safe Fail	550 V	2000 V	20 kA	200 kA	74 g (0.163 lb)

### Specifications

<b>Network Systems</b>	TN-S
<b>Mode of Protection</b>	L-PE, N-PE
<b>Nominal Discharge Current (8/20 <math>\mu</math>s) (<math>I_n</math>)</b>	20 kA
<b>Maximum Discharge Current (8/20 <math>\mu</math>s) (<math>I_{max}</math>)</b>	Up to 50 kA
<b>Protective Elements</b>	High Energy MOV
<b>Response Time (<math>t_A</math>)</b>	< 25 ns
<b>Back-Up Fuse (max)</b>	315 A/250 A Gg
<b>Number of Ports</b>	1
<b>Mechanical &amp; Environmental</b>	
<b>Operating Temperature Range (<math>T_o</math>)</b>	-40 °C to +80 °C (-40 °F to +185 °F)
<b>Permissible Operating Humidity (RH)</b>	5% to 95%
<b>Altitude (max)</b>	4,000 m (13,123 ft)
<b>Terminal Screw Torque (<math>M_{max}</math>)</b>	4.5 Nm (39.9 lbf-in)
<b>Conductor Cross Section (max)</b>	35 mm <sup>2</sup> (2 AWG) (Solid, Stranded)/ 25 mm <sup>2</sup> (4 AWG) (Flexible)
<b>Mounting</b>	35 mm DIN Rail, EN60715
<b>Degree of Protection</b>	IP20 (built-in)
<b>Housing Material</b>	Thermoplastic: Extinguishing Degree UL 94 V-0

<b>Thermal Protection Operating State/Fault Indication</b>	Yes
<b>Remote Contact Switching Capacity</b>	Green Flag/No Green Flag
<b>Remote Contact Conductor Cross Section (max)</b>	AC: 250 V/1 A, 125 V/1 A; DC: 48 V/0.5 A, 24 V/0.5 A, 12 V/0.5 A
<b>Standards Passed*</b>	1.5 mm <sup>2</sup> (16 AWG) (Solid) IEC 61643-11:2011 EN 61643-11:2012 UL 1449, 4th edition

<b>Product Dimensions</b>	
<b>4TE Module and Base</b>	<b>H</b> 90.0 mm (3.54"); <b>W</b> 72.0 mm (2.84"); <b>D</b> 70.0 mm (2.76")
<b>1TE Replacement Module</b>	<b>H</b> 45.0 mm (1.77"); <b>W</b> 18.0 mm (0.71"); <b>D</b> 57.2mm (2.25")
<b>Package Dimensions</b>	
<b>4TE Module and Base</b>	<b>H</b> 102.0 mm (4.01"); <b>W</b> 82.0 mm (3.23"); <b>D</b> 110.0 mm (4.33")
<b>1TE Replacement Module</b>	<b>H</b> 102.0 mm (4.01"); <b>W</b> 28.0 mm (1.10"); <b>D</b> 110.0 mm (4.33")

\*SPD2-550-4P0-R and SPD2-550-M are UL Listed only

Warranty – Visit [www.littelfuse.com/warranty](http://www.littelfuse.com/warranty) for details.



# Surge Protective Devices

## SPD2 1P+1 SERIES

### Class II/Type 2/Type 1 CA Pluggable Multi-Pole

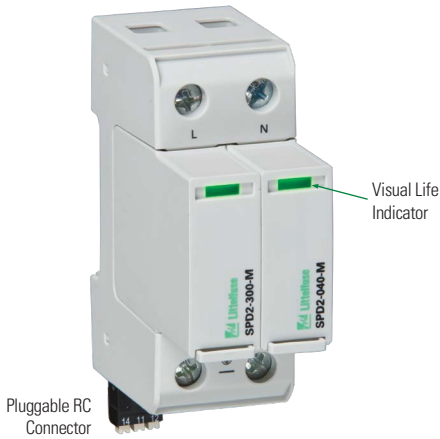

### Internal Configuration

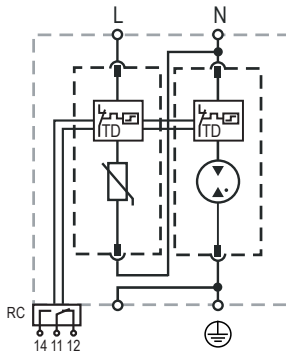

#### Legend

- L Line
- N Neutral
- ⊕ Protective Earth
- RC Remote Contacts
- TD Thermal Disconnection

### Description

Surge protection devices (SPDs) provide equipment protection from overvoltage events lasting micro-seconds. By limiting the overvoltage to the equipment during these events, costly equipment damage and downtime can be mitigated.

The surge protection devices for the 1+1 configuration are available for 60 V to 277 V nominal voltage sub-distribution board applications.

### Features & Benefits

FEATURES	BENEFITS
<b>Capability to clamp and withstand high-energy transients</b>	Ensures low-residual voltage during high-energy surge events and higher nominal discharge current to prevent disruption, downtime, and degradation or damage to equipment
<b>UL and VDE-IEC compliant in single part number</b>	One component can be utilized globally, reducing inventory needs and simplifying allocation of parts
<b>Interlocking tab mechanism</b>	Secures module to withstand vibration
<b>No additional overcurrent protection devices required in UL applications</b>	Reduces the number of components and costs required for protection
<b>Compact footprint</b>	Increases panel design flexibility
<b>Visual life indicator</b>	Quick visual determines module replacement status to avoid loss of protection
<b>Pluggable modules</b>	Fast and simple to replace, minimizing maintenance and downtime. No tools required
<b>Thermal protection</b>	Eliminates catastrophic failure
<b>IP20 protection rating</b>	Finger-safe design increases worker protection

### Module & Base Ordering Information

Ordering Number	IEC Electrical										UL Electrical				Single Unit Weight
	Nominal AC Voltage (50/60Hz) (U <sub>n</sub> )	Maximum Continuous Operating AC Voltage (L-N/N-PE U <sub>c</sub> )	Nominal Discharge Current (8/20 μs) (L-N/N-PE I <sub>n</sub> )	Maximum Discharge Current (8/20 μs) (L-N/N-PE I <sub>max</sub> )	Voltage Protection Level (L-N/N-PE U <sub>p</sub> )	Follow Current Interrupt Rating (N-PE I <sub>f</sub> )	Short-Circuit AC Current Rating (L-N I <sub>sc(R)</sub> )	TOV Withstand 5 s (L-N U <sub>f</sub> )	TOV 120 min (L-N U <sub>f</sub> / Mode)	TOV Withstand 200 ms (N-PE U <sub>f</sub> )	Maximum Continuous AC Operating Voltage (L-N / N-PE MCOV)	Voltage Protection Rating (L-N / N-PE VPR)	Nominal Discharge Current (8/20 μs) (L-N / N-PE I <sub>n</sub> )	Short-Circuit Current Rating (L-N SCGR)	
SPD2-075-1P1-R	60 V	75 V / 305 V	20 kA / 40 kA	50 kA / 65 kA	800 V / 1500 V	100 A <sub>RMS</sub>	25 kA / 50 kA	114 V	114 V / Withstand	1200 V	75 V / 305 V	330 V / 1000 V	20 kA / 20 kA	100 kA	124 g (0.274 lb)
SPD2-150-1P1-R	120 V	150 V / 305 V	20 kA / 40 kA	50 kA / 65 kA	1250 V / 1500 V	100 A <sub>RMS</sub>	25 kA / 50 kA	229 V	229 V / Withstand	1200 V	150 V / 305 V	600 V / 1000 V	20 kA / 20 kA	200 kA	128 g (0.283 lb)
SPD2-300-1P1-R	240 V	300 V / 305 V	20 kA / 40 kA	50 kA / 65 kA	1500 V / 1500 V	100 A <sub>RMS</sub>	25 kA / 50 kA	337 V	442 V / Safe Fail	1200 V	300 V / 305 V	900 V / 1000 V	20 kA / 20 kA	150 kA	135 g (0.298 lb)
SPD2-350-1P1-R	277 V	350 V / 305 V	20 kA / 40 kA	50 kA / 65 kA	1750 V / 1500 V	100 A <sub>RMS</sub>	25 kA / 50 kA	403 V	529 V / Safe Fail	1200 V	350 V / 305 V	1000 V / 1000 V	20 kA / 20 kA	200 kA	140 g (0.309 lb)

# Surge Protective Devices

## SPD2 1P+1 SERIES

### Module & Base Part Numbering System



### Module Only Part Numbering System

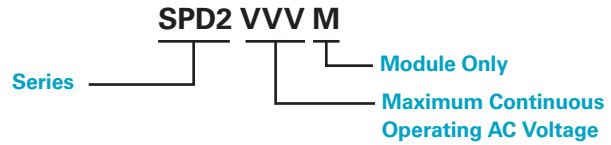

### Replacement Module Ordering Information

Ordering Number	IEC Electrical										UL Electrical				Single Unit Weight
	Nominal AC Voltage (50/60Hz) ( $U_n$ )	Maximum Continuous Operating AC Voltage (L-N / N-PE $U_c$ )	Nominal Discharge Current (8/20 $\mu$ s) (L-N / N-PE $I_n$ )	Maximum Discharge Current (8/20 $\mu$ s) (L-N / N-PE $I_{max}$ )	Voltage Protection Level (L-N / N-PE $U_p$ )	Follow Current Interrupt Rating (N-PE $I_f$ )	Short-Circuit AC Current Rating (L-N $I_{SCR}$ )	TOV Withstand 5 s (L-N $U_t$ )	TOV 120 min (L-N $U_t$ ) / Mode	TOV Withstand 200 ms (N-PE $U_t$ )	Maximum Continuous AC Operating Voltage (L-N / N-PE MCOV)	Voltage Protection Rating (L-N / N-PE VPR)	Nominal Discharge Current (8/20 $\mu$ s) (L-N / N-PE $I_n$ )	Short-Circuit Current Rating (L-N SCCR)	
SPD2-040-M	0 V	40 V / 305 V	20 kA / 40 kA	50 kA / 65 kA	1500 V (N-PE)	100 A <sub>RMS</sub>	25 kA / 50 kA	N/A	N/A	1200 V	305 V (N-PE)	1000 V (N-PE)	20 kA / 20 kA	N/A	42 g (0.093 lb)
SPD2-075-M	60 V	75 V / 305 V	20 kA / 40 kA	50 kA / 65 kA	800 V / 1500 V	100 A <sub>RMS</sub>	25 kA / 50 kA	114 V	114 V / Withstand	1200 V	75 V / 305 V	330 V / 1000 V	20 kA / 20 kA	100 kA	50 g (0.111 lb)
SPD2-150-M	120 V	150 V / 305 V	20 kA / 40 kA	50 kA / 65 kA	1250 V / 1500 V	100 A <sub>RMS</sub>	25 kA / 50 kA	229 V	229 V / Withstand	1200 V	150 V / 305 V	600 V / 1000 V	20 kA / 20 kA	200 kA	54 g (0.120 lb)
SPD2-300-M	240 V	300 V / 305 V	20 kA / 40 kA	50 kA / 65 kA	1500 V / 1500 V	100 A <sub>RMS</sub>	25 kA / 50 kA	337 V	442 V / Safe Fail	1200 V	300 V / 305 V	900 V / 1000 V	20 kA / 20 kA	150 kA	61 g (0.135 lb)
SPD2-350-M	277 V	350 V / 305 V	20 kA / 40 kA	50 kA / 65 kA	1750 V / 1500 V	100 A <sub>RMS</sub>	25 kA / 50 kA	403 V	529 V / Safe Fail	1200 V	350 V / 305 V	1000 V / 1000 V	20 kA / 20 kA	200 kA	68 g (0.146 lb)

### Specifications

<b>Network Systems</b>	TT, TN-S
<b>Mode of Protection</b>	L-N, N-PE
<b>Nominal Discharge Current (8/20 <math>\mu</math>s) (L-N / N-PE <math>I_n</math>)</b>	20 kA/40 kA
<b>Maximum Discharge Current (8/20 <math>\mu</math>s) (L-N / N-PE <math>I_{max}</math>)</b>	50 kA/65 kA
<b>Protective Elements</b>	High Energy MOV and GDT
<b>Response Time (L-N / N-PE <math>t_A</math>)</b>	< 25 ns
<b>Back-Up Fuse (max)</b>	315 A/250 A Gg
<b>Number of Ports</b>	1
<b>Mechanical &amp; Environmental</b>	
<b>Operating Temperature Range (<math>T_o</math>)</b>	-40 °C to +80 °C (-40 °F to +185 °F)
<b>Permissible Operating Humidity (RH)</b>	5% to 95%
<b>Altitude (max)</b>	4,000 m (13,123 ft)
<b>Terminal Screw Torque (<math>M_{max}</math>)</b>	4.5 Nm (39.9 lbf-in)
<b>Conductor Cross Section (max)</b>	35 mm <sup>2</sup> (2 AWG) (Solid, Stranded) / 25 mm <sup>2</sup> (4 AWG) (Flexible)
<b>Mounting</b>	35 mm DIN Rail, EN60715
<b>Degree of Protection</b>	IP20 (built-in)
<b>Housing Material</b>	Thermoplastic: Extinguishing Degree UL 94 V-0

<b>Thermal Protection</b>	Yes
<b>Operating State/Fault Indication</b>	Green Flag/No Green Flag
<b>Remote Contact Switching Capacity</b>	AC: 250 V/1 A, 125 V/1 A; DC: 48 V/0.5 A, 24 V/0.5 A, 12 V/0.5 A
<b>Remote Contact Conductor Cross Section (max)</b>	1.5 mm <sup>2</sup> (16 AWG) (Solid)
<b>Standards Passed</b>	IEC 61643-11:2011 EN 61643-11:2012 UL 1449, 4th edition

<b>Product Dimensions</b>	
<b>2TE Module and Base</b>	<b>H</b> 90.0 mm (3.54"); <b>W</b> 36.0 mm (1.42"); <b>D</b> 70.0 mm (2.76")
<b>1TE Replacement Module</b>	<b>H</b> 45.0 mm (1.77"); <b>W</b> 18.0 mm (0.71"); <b>D</b> 57.2mm (2.25")
<b>Package Dimensions</b>	
<b>2TE Module and Base</b>	<b>H</b> 102.0 mm (4.01"); <b>W</b> 46.0 mm (1.81"); <b>D</b> 110.0 mm (4.33")
<b>1TE Replacement Module</b>	<b>H</b> 102.0 mm (4.01"); <b>W</b> 28.0 mm (1.10"); <b>D</b> 110.0 mm (4.33")

Warranty – Visit [www.littelfuse.com/warranty](http://www.littelfuse.com/warranty) for details.

# Surge Protective Devices

## SPD2 3P+1 SERIES

### Class II/Type 2/Type 1 CA Pluggable Multi-Pole



### Description

Surge protection devices (SPDs) provide equipment protection from transient overvoltage events lasting micro-seconds. By limiting the overvoltage to the equipment during these events, costly damage and downtime can be mitigated.

The surge protection devices for the 3+1 configuration are available for 240 V to 277 V nominal voltage sub-distribution board applications.

### Features & Benefits

FEATURES	BENEFITS
<b>Capability to clamp and withstand high-energy transients</b>	Ensures low-residual voltage during high-energy surge events and higher nominal discharge current to prevent disruption, downtime, and degradation or damage to equipment
<b>UL and VDE-IEC compliant in single part number</b>	One component can be utilized globally, reducing inventory needs and simplifying allocation of parts
<b>Interlocking tab mechanism</b>	Secures module to withstand vibration
<b>No additional overcurrent protection devices required in UL applications</b>	Reduces the number of components and costs required for protection
<b>Compact footprint</b>	Increases panel design flexibility
<b>Visual life indicator</b>	Quick visual determines module replacement status to avoid loss of protection
<b>Pluggable modules</b>	Fast and simple to replace, minimizing maintenance and downtime. No tools required
<b>Thermal protection</b>	Eliminates catastrophic failure
<b>IP20 protection rating</b>	Finger-safe design increases worker protection

### Internal Configuration

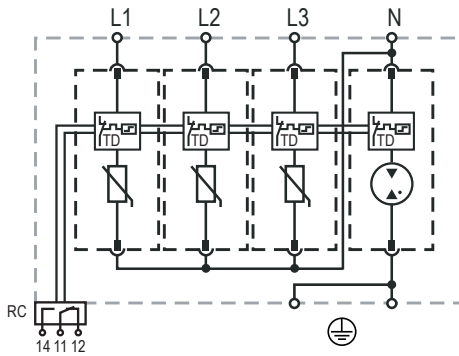

### Legend

- L Line
- N Neutral
- ⊕ Protective Earth
- RC Remote Contacts
- TD Thermal Disconnection

### Module & Base Ordering Information

Ordering Number	IEC Electrical										UL Electrical				Single Unit Weight
	Nominal AC Voltage (50/60Hz) (U <sub>n</sub> )	Maximum Continuous Operating AC Voltage (L-N / N-PE U <sub>c</sub> )	Nominal Discharge Current (8/20 μs) (L-N / N-PE I <sub>n</sub> )	Maximum Discharge Current (8/20 μs) (L-N / N-PE I <sub>max</sub> )	Voltage Protection Level (L-N / N-PE U <sub>p</sub> )	Follow Current Interrupt Rating (N-PE I <sub>f</sub> )	Short-Circuit AC Current Rating (L-N) (I <sub>sc(R)</sub> )	TOV Withstand 5 s (L-N U <sub>t</sub> )	TOV 120 min (L-N U <sub>t</sub> ) / Mode	TOV Withstand 200 ms (N-PE U <sub>t</sub> )	Maximum Continuous AC Operating Voltage (L-N / N-PE MCOV)	Voltage Protection Rating (L-N / N-PE VPR)	Nominal Discharge Current (8/20 μs) (L-N / N-PE I <sub>n</sub> )	Short-Circuit Current Rating (L-N SCCR)	
SPD2-300-3P1-R	240 V	300 V / 305 V	20 kA / 40 kA	50 kA / 65 kA	1500 V / 1500 V	100 A <sub>RMS</sub>	25 kA / 50 kA	337 V	442 V / Safe Fail	1200 V	300 V / 305 V	900 V / 1000 V	20 kA / 20 kA	150 kA	486 g (1.072 lb)
SPD2-350-3P1-R	277 V	350 V / 305 V	20 kA / 40 kA	50 kA / 65 kA	1750 V / 1500 V	100 A <sub>RMS</sub>	25 kA / 50 kA	403 V	529 V / Safe Fail	1200 V	350 V / 305 V	1000 V / 1000 V	20 kA / 20 kA	200 kA	501 g (1.105 lb)

# Surge Protective Devices

## SPD2 3P+1 SERIES

### Module & Base Part Numbering System



### Module Only Part Numbering System

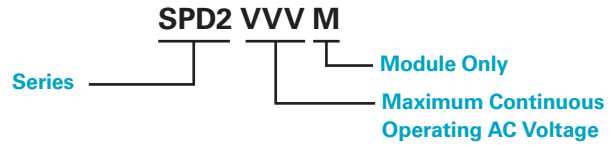

### Replacement Module Ordering Information

Ordering Number	IEC Electrical										UL Electrical				Single Unit Weight
	Nominal AC Voltage (50/60Hz) (U <sub>N</sub> / U <sub>c</sub> )	Maximum Continuous Operating AC Voltage (L-N / N-PE U <sub>c</sub> )	Nominal Discharge Current (8/20 μs) (L-N / N-PE I <sub>n</sub> )	Maximum Discharge Current (8/20 μs) (L-N / N-PE I <sub>max</sub> )	Voltage Protection Level (L-N / N-PE U <sub>p</sub> )	Follow Current Interrupt Rating (N-PE I <sub>cc</sub> )	Short-Circuit AC Current Rating (L-N I <sub>sc(rfp)</sub> )	TOV Withstand 5 s (L-N U <sub>t</sub> )	TOV 120 min (L-N U <sub>t</sub> ) / Mode	TOV Withstand 200 ms (N-PE U <sub>t</sub> )	Maximum Continuous AC Operating Voltage (L-N / N-PE MCOV)	Voltage Protection Rating (L-N / N-PE VPR)	Nominal Discharge Current (8/20 μs) (L-N / N-PE I <sub>n</sub> )	Short-Circuit Current Rating (L-N SCOR)	
SPD2-040-M	0 V	40 V / 305 V	20 kA / 40 kA	50 kA / 65 kA	1500 V (N-PE U <sub>p</sub> )	100 A <sub>RMS</sub>	25 kA / 50 kA	N/A	N/A	1200 V	305 V (N-PE)	1000 V (N-PE)	20 kA / 20 kA	N/A	42 g (0.093 lb)
SPD2-300-M	240 V	300 V / 305 V	20 kA / 40 kA	50 kA / 65 kA	1500 V / 1500 V	100 A <sub>RMS</sub>	25 kA / 50 kA	337 V	442 V / Safe Fail	1200 V	300 V / 305 V	900 V / 1000 V	20 kA / 20 kA	150 kA	61 g (0.135 lb)
SPD2-350-M	277 V	350 V / 305 V	20 kA / 40 kA	50 kA / 65 kA	1750 V / 1500 V	100 A <sub>RMS</sub>	25 kA / 50 kA	403 V	529 V / Safe Fail	1200 V	350 V / 305 V	1000 V / 1000 V	20 kA / 20 kA	200 kA	66 g (0.146 lb)

### Specifications

<b>Network Systems</b>	TT, TN-S
<b>Mode of Protection</b>	L-N, N-PE
<b>Nominal Discharge Current (8/20 μs) (L-N / N-PE I<sub>n</sub>)</b>	20 kA/40 kA
<b>Maximum Discharge Current (8/20 μs) (L-N / N-PE I<sub>max</sub>)</b>	50 kA/65 kA
<b>Protective Elements</b>	High Energy MOV and GDT
<b>Response Time (L-N / N-PE t<sub>A</sub>)</b>	< 25 ns
<b>Back-Up Fuse (max)</b>	315 A/250 A Gg
<b>Number of Ports</b>	1
<b>Mechanical &amp; Environmental</b>	
<b>Operating Temperature Range (T<sub>a</sub>)</b>	-40 °C to +80 °C (-40 °F to +185 °F)
<b>Permissible Operating Humidity (RH)</b>	5% to 95%
<b>Altitude (max)</b>	4,000 m (13,123 ft)
<b>Terminal Screw Torque (M<sub>max</sub>)</b>	4.5 Nm (39.9 lbf-in)
<b>Conductor Cross Section (max)</b>	35 mm <sup>2</sup> (2 AWG) (Solid, Stranded) / 25 mm <sup>2</sup> (4 AWG) (Flexible)
<b>Mounting</b>	35 mm DIN Rail, EN60715
<b>Degree of Protection</b>	IP20 (built-in)
<b>Housing Material</b>	Thermoplastic: Extinguishing Degree UL 94 V-0

<b>Thermal Protection</b>	Yes
<b>Operating State/Fault Indication</b>	Green Flag/No Green Flag
<b>Remote Contact Switching Capacity</b>	AC: 250 V/1 A, 125 V/1 A; DC: 48 V/0.5 A, 24 V/0.5 A, 12 V/0.5 A
<b>Remote Con Conductor Cross Section (max)</b>	1.5 mm <sup>2</sup> (16 AWG) (Solid)
<b>Standards Passed</b>	IEC 61643-11:2011 EN 61643-11:2012 UL 1449, 4th edition

<b>Product Dimensions</b>	
<b>4TE Module and Base</b>	<b>H</b> 90.0 mm (3.54"); <b>W</b> 72.0 mm (2.84"); <b>D</b> 70.0 mm (2.76")
<b>1TE Replacement Module</b>	<b>H</b> 45.0 mm (1.77"); <b>W</b> 18.0 mm (0.71"); <b>D</b> 57.2 mm (2.25")
<b>Package Dimensions</b>	
<b>4TE Module and Base</b>	<b>H</b> 102.0 mm (4.01"); <b>W</b> 82.0 mm (3.23"); <b>D</b> 110.0 mm (4.33")
<b>1TE Replacement Module</b>	<b>H</b> 102.0 mm (4.01"); <b>W</b> 28.0 mm (1.10"); <b>D</b> 110.0 mm (4.33")

Warranty – Visit [www.littelfuse.com/warranty](http://www.littelfuse.com/warranty) for details.



# Surge Protective Devices

## SPD2 PV SERIES

Class 2 (IEC)/Type 2 (EN)/Type 1CA (UL)  
Pluggable Multi-Pole for PV Systems



### Description

Surge protective devices (SPDs) provide equipment protection from transient overvoltage events lasting micro-seconds. By limiting the overvoltage to the equipment during these events, costly damage and downtime can be mitigated.

The surge protective devices for solar string box and inverter applications are available in 1100 and 1500 V dc in the 3+0 configuration.

### Features & Benefits

FEATURES	BENEFITS
<b>Capability to clamp and withstand high-energy transients</b>	Ensures low-residual voltage during high-energy surge events and higher nominal discharge current to prevent disruption, downtime, and degradation or damage to equipment
<b>No additional overcurrent protection devices required in UL applications</b>	Reduces the number of components and costs required for protection
<b>Compact footprint</b>	Increases panel design flexibility
<b>Visual life indicator</b>	Quick visual determines module replacement status to avoid loss of protection
<b>Pluggable modules</b>	Fast and simple to replace, minimizing maintenance and downtime. No tools required
<b>Thermal protection</b>	Eliminates catastrophic failure
<b>IP20 protection rating</b>	Finger-safe design increases worker protection

### Internal Configuration

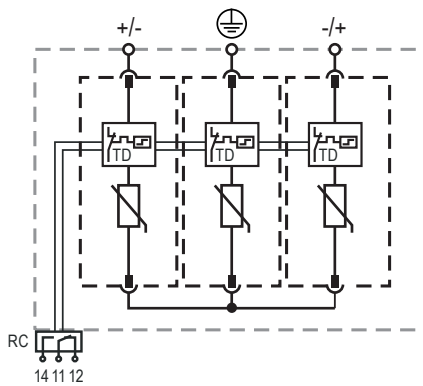

### Legend

- Protective Earth
- RC Optional Remote Contact
- TD Thermal Disconnection

### Module & Base Ordering Information

Ordering Number	IEC Electrical						UL Electrical				Single Unit Weight
	Maximum Continuous Operating Dc Voltage ( $U_{CPV}$ )	Nominal Discharge Current (8/20 $\mu$ s) ( $I_n$ )	Maximum Discharge Current (8/20 $\mu$ s) ( $I_{max}$ )	Total Discharge Current ( $I_{Total}$ )	Voltage Protection Level ( $U_p$ )	Short-Circuit Current Rating ( $I_{SCPV}$ )	Maximum Permitted Dc Voltage ( $U_{pVdc}$ )	Voltage Protection Rating (VPR)	Nominal Discharge Current (8/20 $\mu$ s) ( $I_n$ )	Short-Circuit Current Rating (SCCR)	
SPD2-PV11-3PO SPD2-PV11-3PO-R	1100 V	20 kA	40 kA	50 kA	4200 V	9 kA	1100 V	3000 V	20 kA	50 kA	333 g (0.734 lb)
SPD2-PV15-3PO SPD2-PV15-3PO-R	1500 V	15 kA	40 kA	40 kA	4800 V	9 kA	1500 V	4000 V	20 kA	65 kA	363 g (0.800 lb)

# Surge Protective Devices

## SPD2 PV SERIES

### Module & Base Part Numbering System

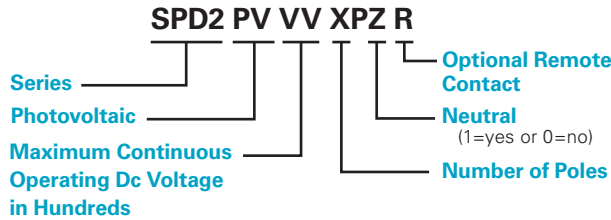

### Module Only Part Numbering System

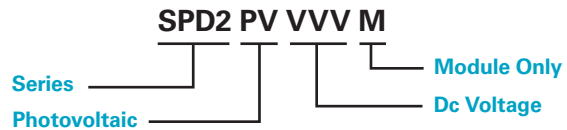

### Replacement Module Ordering Information

Ordering Number	IEC Electrical						UL Electrical				Single Unit Weight
	Maximum Continuous Operating Dc Voltage ( $U_{CPV}$ )	Nominal Discharge Current (8/20 $\mu$ s) ( $I_n$ )	Maximum Discharge Current (8/20 $\mu$ s) ( $I_{max}$ )	Total Discharge Current ( $I_{Total}$ )	Voltage Protection Level ( $U_p$ )	Short-Circuit Current Rating ( $I_{SCPV}$ )	Maximum Permitted Dc Voltage ( $U_{pVdc}$ )	Voltage Protection Rating (VPR)	Nominal Discharge Current (8/20 $\mu$ s) ( $I_n$ )	Short-Circuit Current Rating (SCCR)	
SPD2-PV550-M	1100 V	20 kA	40 kA	50 kA	4200 V	9 kA	1100 V	3000 V	20 kA	50 kA	61 g (0.134 lb)
SPD2-PV750-M	1500 V	15 kA	40 kA	40 kA	4800 V	9 kA	1500 V	4000 V	20 kA	65 kA	71 g (0.157 lb)

### Specifications

<b>Mode of Protection</b>	(+) - PE, (-) - PE, (+) - (-)
<b>Nominal Discharge Current (8/20 <math>\mu</math>s) (<math>I_n</math>)</b>	20 kA
<b>Maximum Discharge Current (8/20 <math>\mu</math>s) (<math>I_{max}</math>)</b>	Up to 40 kA
<b>Protective Elements</b>	High Energy MOV
<b>Response Time (<math>t_A</math>)</b>	< 25 ns
<b>Number of Ports</b>	1
<b>Mechanical &amp; Environmental</b>	
<b>Operating Temperature Range (<math>T_a</math>)</b>	-40 °C to +80 °C (-40 °F to +185 °F)
<b>Permissible Operating Humidity (RH)</b>	5% to 95%
<b>Altitude (max)</b>	4,000 m (13,123 ft)
<b>Terminal Screw Torque (<math>M_{max}</math>)</b>	4.5 Nm (39.9 lbf-in)
<b>Conductor Cross Section (max)</b>	35 mm <sup>2</sup> (2 AWG) (Solid, Stranded)/ 25 mm <sup>2</sup> (4 AWG) (Flexible)
<b>Mounting</b>	35 mm DIN Rail, EN60715
<b>Degree of Protection</b>	IP20 (built-in)
<b>Housing Material</b>	Thermoplastic: Extinguishing Degree UL 94 V-0
<b>Thermal Protection</b>	Yes

<b>Operating State/Fault Indication</b>	Green Flag/No Green Flag
<b>Remote Contact Switching Capacity</b>	Ac: 250 V/1 A, 125 V/1 A; Dc: 48 V/0.5 A, 24 V/0.5 A, 12 V/0.5 A
<b>Remote Contact Conductor Cross Section (max)</b>	1.5 mm <sup>2</sup> (16 AWG) (Solid)
<b>Standards Passed</b>	EN 50539-11:2013+A1:2014 UL 1449 4th Edition; E320116

<b>Product Dimensions</b>	
<b>3TE Module and Base</b>	<b>H</b> 90.7 mm (3.57"); <b>W</b> 53.8 mm (2.11"); <b>D</b> 66.1 mm (2.60")
<b>1TE Replacement Module</b>	<b>H</b> 45.0 mm (1.77"); <b>W</b> 18.0 mm (0.71"); <b>D</b> 57.2 mm (2.25")
<b>Package Dimensions</b>	
<b>3TE Module and Base</b>	<b>H</b> 102.0 mm (4.01"); <b>W</b> 64.0 mm (2.52"); <b>D</b> 110.0 mm (4.33")
<b>1TE Replacement Module</b>	<b>H</b> 102.0 mm (4.01"); <b>W</b> 28.0 mm (1.10"); <b>D</b> 110.0 mm (4.33")

Warranty – Visit [www.littelfuse.com/warranty](http://www.littelfuse.com/warranty) for details.

# Surge Protective Devices

## SPD2 SERIES CROSS-REFERENCE GUIDE

This cross-reference tool includes the most popular Type 2 surge protection devices. It is meant to serve as a guide for quick identification and product selection. Please check all applicable specifications prior to making a product substitution or selection.

Littelfuse Part Number	Surge Device Type	Nominal AC or DC Voltage	Number of Poles	Neutral	ABB Part Number	Bourns Part Number	Citel Part Number	DEHN Part Number	Phoenix Contact Part Number	Raycap Part Number
SPD2-075-1P0-R	2	75 V ac	1	No	OVR T2 15-75 P TS	—	—	DEHNguard S 48 FM	VAL-MS 60/FM	ProTec T2-75-1+0-R
SPD2-075-1P1-R	2	75 V ac	1	Yes	—	—	DS240S-75VDC	—	VAL-VS- 48/40/1+1-FM	ProTec T2-75-1+1-R
SPD2-150-1P0-R	2	150 V ac	1	No	OVR T2 40-150 P TS U	1250-1S-120	DS41S-120	DEHNguard SU 1P 120 R	VAL-US- 120/40/1+0-FM	ProTec T2-150-1+0-R
SPD2-150-2P0-R	2	150 V ac	2	No	OVR T2 1N 40-150 P TS U	1250-2S-120	DS42S-120	DEHNguard MU SP 240 3W+G R	VAL-US- 120/40/2+0-FM	ProTec T2-150-2+0-R
SPD2-150-3P0-R	2	150 V ac	3	No	OVR T2 2N 40-150 P TS U	1250-3S-120	DS43S-120	DEHNguard MU 3PY 208 3W+G R	VAL-SEC-T2- 3C-175-FM	ProTec T2-150-3+0-R
SPD2-150-4P0-R	2	150 V ac	4	No	OVR T2 3N 40-150 P TS U	1250-4S-120	DS44S-120	DEHNguard MU 3PY 208 4W+G R	VAL-US- 120/40/3+1-FM	ProTec T2-150-4+0-R
SPD2-150-1P1-R	2	150 V ac	1	Yes	—	—	DS42S-120/G	—	VAL-SEC-T2- 1S-175-FM	ProTec T2-150-1+1-R
SPD2-300-1P0-R	2	300 V ac	1	No	OVR T2 40-275 P TS QS	1250-1S-230	DS41S-230	DEHNguard SU 1P 240 R	VAL-US- 277/40/1+0-FM	ProTec T2-300-1+0-R
SPD2-300-2P0-R	2	300 V ac	2	No	OVR T2 1N 40-275 P TS QS	1250-2S-230	DS42S-230	DEHNguard MU SP 480 3W+G R	VAL-MS 230/2+0-FM	ProTec T2-300-2+0-R
SPD2-300-3P0-R	2	300 V ac	3	No	OVR T2 3L 40-275 P TS QS	1250-3S-230	DS43S-230	DEHNguard M TNC 275 FM	VAL-CP- 3C-350	ProTec T2-300-3+0-R
SPD2-300-4P0-R	2	300 V ac	4	No	OVR T2 4L 40-275 P TS QS	1250-4S-230	DS44S-230	DEHNguard M TNS 275 FM	VAL-US- 277/40/4+0-FM	ProTec T2-300-4+0-R
SPD2-300-1P1-R	2	300 V ac	1	Yes	OVR T2 1N 40-275 P TS QS	—	DS42S-230/G	DEHNguard MU 3PY 480 4W+G R	VAL-MS 230/1+1-FM	ProTec T2-300-1+1-R
SPD2-300-3P1-R	2	300 V ac	3	Yes	OVR T2 3N 40-275 P TS QS	—	DS44S-230/G	DEHNguard M TT 275 FM	VAL-MS 230/3+1-FM	ProTec T2-300-3+1-R
SPD2-350-1P0-R	2	350 V ac	1	No	OVR T2 40-320 P TS U	1250-1S-400	DS41S-400	DEHNguard SU 1P 347 R	—	ProTec T2-350-1+0-R
SPD2-350-2P0-R	2	350 V ac	2	No	OVR T2 1N 40-320 P TS U	1250-2S-400	DS42S-400	—	VAL-SEC-T2- 2C-350-FM	ProTec T2-350-2+0-R
SPD2-350-3P0-R	2	350 V ac	3	No	OVR T2 3L 40-320 P TS U	1250-3S-400	DS43S-400	DEHNguard MU 3PY 480 3W+G R	VAL-SEC-T2- 3C-350-FM	ProTec T2-350-3+0-R
SPD2-350-4P0-R	2	350 V ac	4	No	OVR T2 3N 40-320 P TS U	1250-4S-400	DS44S-400	DEHNguard M TNS 385 FM	—	ProTec T2-350-4+0-R
SPD2-350-1P1-R	2	350 V ac	1	Yes	OVR T2 1N 40-350 P TS QS	—	—	DEHNguard M TT 2P 385 FM	VAL-SEC-T2- 1S-350-FM	ProTec T2-350-1+1-R
SPD2-350-3P1-R	2	350 V ac	3	Yes	—	—	—	DEHNguard M TT 385 FM	VAL-SEC-T2- 3S-350-FM	ProTec T2-350-3+1-R
SPD2-480-1P0-R	2	480 V ac	1	No	OVR T2 40-440 P TS U	1250-1S-480	DS41S-400	DEHNguard S 440 FM	VAL-US- 347/30/1+0-FM	ProTec T2-480-1+0-R
SPD2-480-2P0-R	2	480 V ac	2	No	OVR T2 1N 40-440 P TS U	1250-2S-480	DS42S-400	—	VAL-US- 347/30/1+1V-FM	ProTec T2-480-2+0-R
SPD2-480-3P0-R	2	480 V ac	3	No	OVR T2 3L 40-440 P TS U	1250-3S-480	DS43S-400	DEHNguard MU 3PY 600 3W+G R	VAL-US- 347/30/3+0-FM	ProTec T2-480-3+0-R
SPD2-480-4P0-R	2	480 V ac	4	No	OVR T2 3N 40-440 P TS U	1250-4S-480	DS44S-400	DEHNguard MU 3PY 600 4W+G R	—	ProTec T2-480-4+0-R
SPD2-550-1P0-R	2	550 V ac	1	No	OVR T2 40-550 P TS U	—	DS41S-600	DEHNguard S 600 FM	VAL-US- 480D/30/1+0-FM	ProTec T2-550-1+0-R
SPD2-550-2P0-R	2	550 V ac	2	No	OVR 1N 40-550 P TS U	—	—	—	VAL-US- 480D/30/2+0-FM	ProTec T2-550-2+0-R
SPD2-550-3P0-R	2	550 V ac	3	No	OVR T2 3L 40-550 P TS U	—	—	DEHNguard MU 3PD 480 3W+G R	VAL-US- 480D/30/3+0-FM	ProTec T2-550-3+0-R
SPD2-550-4P0-R	2	550 V ac	4	No	OVR T2 3N 40-550 P TS U	—	—	—	VAL-US- 480HLD/30/3+1-FM	ProTec T2-550-4+0-R
SPD2-750-1P0-R	2	750 V ac	1	No	OVR T2 40-600 P TS QS	—	—	DEHNguard S WE 600 FM	—	ProTec T2-750-1+0-R
SPD2-750-2P0-R	2	750 V ac	2	No	—	—	—	—	—	ProTec T2-750-2+0-R
SPD2-750-3P0-R	2	750 V ac	3	No	OVR T2 3L 40-600 P TS QS	—	DS43S-690WD	DEHNguard M WE 600 FM	VAL-MS 750/30/3+0 FM	ProTec T2-750-3+0-R
SPD2-PV11-3P0-R	2	1100 V dc	3	No	OVR PV 40-800 P TS U	1420-PV-1000	DS50VGPVS-1000	DEHNguard M YPV 1200 FM	VAL-MS 1000 DC-PV/2+V-FM	ProTec T2-1100PV-3+0-R
SPD2-PV15-3P0-R	2	1500 V dc	3	No	OVR PV 40-1500H P TS U	—	DV50VGPVS-1500	DEHNguard M YPV 1500 FM	VAL-MB-T2 1500 DC-PV/2+V-FM	ProTec T2-1500PV-3+0-R

# Surge Protective Devices

## SPDN SERIES OVERVIEW

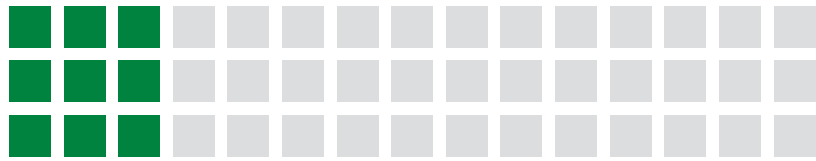

Surge protective devices (SPDs) provide equipment protection from transient overvoltage events lasting micro-seconds. By limiting the overvoltage to the equipment during these events, costly damage and downtime can be mitigated.

The NEMA-style SPDN series for external panel mount is available for 120 V to 480 V nominal voltage sub-distribution board applications. They are ideal for:



Construction



Food and Beverage



Light Industrial



HVAC/R



Oil and Gas



Water/Wastewater



FEATURES	BENEFITS
More direct modes of protection in a smaller package	Increases protection and design flexibility
UL 1283 EMI/RFI filtering – 50 dB from 10 kHz to 100 MHz (SPDN-A only)	Helps mitigate effects on power supplies by decreasing zero crossing during ringing transients to prevent interference on performance or unsafe conditions
Capability to clamp and withstand high-energy transients	Ensures low-residual voltage during high-energy surge events and higher nominal discharge current to prevent disruption, downtime, and degradation or damage to equipment
Stacked Metal Oxide Varistor (MOV) design	Provides more high-transient voltage protection in a compact, multi-layered structure
Installs on the line or load side of the circuit breaker (SPDN-B, C, D) Installs on the load side of the circuit breaker (SPDN-A only)	Simplifies maintenance—without impacting the other parts of the electrical system—by turning breaker off during upkeep
Thermally protected MOV	Eliminates catastrophic failure
Externally LED indicator	Quickly identifies service requirements to avoid loss of protection
Compact footprint	Offers easy retrofit in existing applications where space is limited



# Surge Protective Devices

## SPDN-A SERIES

UL Type 2



### Description

Surge protective devices (SPDs) provide equipment protection from transient overvoltage events lasting micro-seconds. By limiting the overvoltage to the equipment during these events, costly damage and downtime can be mitigated.

The NEMA-style SPDN series for external panel mount is available for 120 V to 480 V nominal voltage sub-distribution board applications.

### Features & Benefits

FEATURES	BENEFITS
<b>More direct modes of protection (L-N, L-G, N-G) in a smaller package</b>	Increases protection and design flexibility
<b>UL 1283 EMI/RFI filtering – 50 dB from 10 kHz to 100 MHz</b>	Helps mitigate effects on power supplies by decreasing zero crossings during ringing transients to prevent interference on performance or unsafe conditions
<b>Capability to clamp and withstand high-energy transients</b>	Ensures low-residual voltage during high-energy surge events and higher nominal discharge current to prevent disruption, downtime, and degradation or damage to equipment
<b>Stacked Metal Oxide Varistor (MOV) design</b>	Provides more high-transient voltage protection in a compact, multi-layered structure
<b>Installs on the load side of the circuit breaker</b>	Simplifies maintenance—without impacting the other parts of the electrical system—by turning breaker off during upkeep
<b>Thermally protected MOV</b>	Eliminates catastrophic failure
<b>External LED Indicator</b>	Quickly identifies service requirements to avoid loss of protection
<b>Compact Footprint</b>	Offers easy retrofit in existing applications where space is limited

### Applications

- Construction
- Food and Beverage
- HVAC/R
- Light Industrial
- Oil and Gas
- Water/Wastewater

# Surge Protective Devices

## SPDN-A SERIES

### Specifications

<b>Maximum Surge Current Rating</b>	Up to 130 kA per Phase
<b>I-nominal Rating</b>	20 kA
<b>UL1449 Short Circuit Current Rating</b>	200 kA
<b>Direct Modes of Protection</b>	L-N, L-G, N-G
<b>UL Type</b>	Type 2
<b>Phase Loss Monitoring</b>	Standard
<b>Audible Alarm</b>	Standard
<b>Protective Elements</b>	Stacked High Energy MOV
<b>Response Time (L-N / N-PE tA)</b>	< 25 ns
<b>Mechanical &amp; Environmental</b>	
<b>Operating Temperature Range (Ta)</b>	-40 °C to +85 °C (-40 °F to +185 °F)
<b>Operating Frequency</b>	50–60 Hz
<b>Typical Connection</b>	18" #12 AWG (pre-wired pig tails) 30 A breaker
<b>Permissible Operating Humidity (RH)</b>	0 % to 95 % non-condensing
<b>Altitude (max)</b>	4,000 m (13,123 ft)
<b>Degree of Protection</b>	IP20 (built-in)
<b>Housing Material</b>	Polycarbonate NEMA 4X – Lid screwed and gasketed
<b>Thermal Protection</b>	Yes
<b>Operating State/Fault Indication</b>	1 Green LED (for each phase), 1 Red LED (Fault Indication)
<b>Remote Contact Switching Capacity</b>	Ac: 240 V/2 A, 125 V/1 A
<b>Ground Reference Monitoring</b>	N-G Voltage > 20 V Detected
<b>Product Dimensions</b>	<b>H</b> 2.75"; <b>W</b> 7.95"; <b>D</b> 3.06"
<b>Product Weight</b>	1.38 lb
<b>Package Dimensions</b>	4-3/8 x 3-1/2 x 9-1/2"
<b>Package Weight</b>	1.8 lb

### Certification & Compliance

<b>cULus</b>	UL 1449, 5th Edition E320116
<b>RoHS</b>	RoHS 2 Directive 2011/65/EU; Directive (EU) 2015/863
<b>REACH</b>	Regulation (EC) No 1907/2006

### Part Numbering System

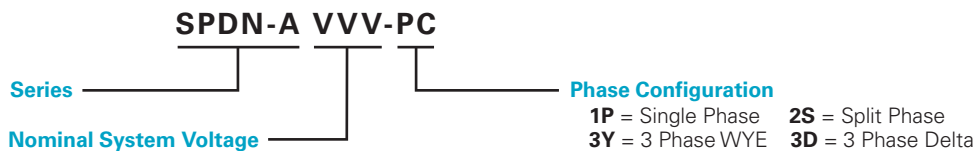

### Ordering Information

ORDERING NUMBER	NOMINAL SYSTEM VOLTAGE	PHASE CONFIGURATION	MAXIMUM CONTINUOUS AC OPERATING VOLTAGE (MCOV)	VOLTAGE PROTECTION RATING (VPR)			
				L-N	L-G	N-G	L-L
SPDN-A120-1P	120	Single Phase	180	700	700	700	
SPDN-A120-2S	120/240	Split Phase	180	700	700	700	1200
SPDN-A120-3Y	208/120	3 Phase WYE	150	700	700	600	1200
SPDN-A240-1P	240	Single Phase	350	1200	1200	1200	
SPDN-A240-3D	240	3 Phase Delta	275		1000		1200
SPDN-A277-3Y	480/277	3 Phase WYE	350	1200	1200	1200	2500
SPDN-A480-3D	480	3 Phase Delta	550		1800		1800

# Surge Protective Devices

## SPDN-B SERIES

UL Type 1



### Description

Surge protective devices (SPDs) provide equipment protection from transient overvoltage events lasting micro-seconds. By limiting the overvoltage to the equipment during these events, costly damage and downtime can be mitigated.

The NEMA-style SPDN series for external panel mount is available for 120 V to 480 V nominal voltage sub-distribution board applications.

### Features & Benefits

FEATURES	BENEFITS
<b>More direct modes of protection (L-N, L-G, N-G) in a smaller package</b>	Increases protection and design flexibility
<b>Capability to clamp and withstand high-energy transients</b>	Ensures low-residual voltage during high-energy surge events and higher nominal discharge current to prevent disruption, downtime, and degradation or damage to equipment
<b>Stacked Metal Oxide Varistor (MOV) design</b>	Provides more high-transient voltage protection in a compact, multi-layered structure
<b>Installs on the line or load side of the circuit breaker</b>	Simplifies maintenance—without impacting the other parts of the electrical system—by turning breaker off during upkeep
<b>Thermally protected MOV</b>	Eliminates catastrophic failure
<b>External LED indicator</b>	Quickly identifies service requirements to avoid loss of protection
<b>Compact footprint</b>	Offers easy retrofit in existing applications where space is limited

### Applications

- Construction
- Food and Beverage
- HVAC/R
- Light Industrial
- Oil and Gas
- Water/Wastewater



# Surge Protective Devices

## SPDN-C SERIES

UL Type 1



### Description

Surge protective devices (SPDs) provide equipment protection from transient overvoltage events lasting microseconds. By limiting the overvoltage to the equipment during these events, costly damage and downtime can be mitigated.

The NEMA-style SPDN series for external panel mount is available for 120 V to 480 V nominal voltage sub-distribution board applications.

### Features & Benefits

FEATURES	BENEFITS
<b>More direct modes of protection (L-N, N-G) in a smaller package</b>	Increases protection and design flexibility
<b>Capability to clamp and withstand high-energy transients</b>	Ensures low-residual voltage during high-energy surge events and higher nominal discharge current to prevent disruption, downtime, and degradation or damage to equipment
<b>Stacked Metal Oxide Varistor (MOV) design</b>	Provides more high-transient voltage protection in a compact, multi-layered structure
<b>Installs on the line or load side of the circuit breaker</b>	Simplifies maintenance—without impacting the other parts of the electrical system—by turning breaker off during upkeep
<b>Thermally protected MOV</b>	Eliminates catastrophic failure
<b>External LED indicator</b>	Quickly identifies service requirements to avoid loss of protection
<b>Compact footprint</b>	Offers easy retrofit in existing applications where space is limited

### Applications

- Construction
- Food and Beverage
- HVAC/R
- Light Industrial
- Oil and Gas
- Water/Wastewater





# Surge Protective Devices

## SPDN-D SERIES

UL Type 1



### Description

Surge protective devices (SPDs) provide equipment protection from transient overvoltage events lasting micro-seconds. By limiting the overvoltage to the equipment during these events, costly damage and downtime can be mitigated.

The NEMA-style SPDN series for external panel mount is available for 120 V to 480 V nominal voltage sub-distribution board applications.

### Features & Benefits

FEATURES	BENEFITS
<b>More direct modes of protection (L-N, N-G) in a smaller package</b>	Increases protection and design flexibility
<b>Capability to clamp and withstand high-energy transients</b>	Ensures low-residual voltage during high-energy surge events and higher nominal discharge current to prevent disruption, downtime, and degradation or damage to equipment
<b>Stacked Metal Oxide Varistor (MOV) design</b>	Provides more high-transient voltage protection in a compact, multi-layered structure
<b>Installs on the line or load side of the circuit breaker</b>	Simplifies maintenance—without impacting the other parts of the electrical system—by turning breaker off during upkeep
<b>Thermally protected MOV</b>	Eliminates catastrophic failure
<b>External LED indicator</b>	Quickly identifies service requirements to avoid loss of protection
<b>Compact footprint</b>	Offers easy retrofit in existing applications where space is limited

### Applications

- Construction
- Food and Beverage
- HVAC/R
- Light Industrial
- Oil and Gas
- Water/Wastewater

# Surge Protective Devices

## SPDN-D SERIES

### Specifications

<b>Maximum Surge Current Rating</b>	Up to 50 kA per phase
<b>I-nominal Rating</b>	20 kA
<b>UL1449 Short Circuit Current Rating</b>	200 kA
<b>Direct Modes of Protection</b>	L-N, N-G
<b>UL Type</b>	Type 1
<b>Protective Elements</b>	Stacked High Energy MOV
<b>Response Time (L-N / N-PE tA)</b>	< 25 ns
<b>Mechanical &amp; Environmental</b>	
<b>Operating Temperature Range (Ta)</b>	-35 °C to +85 °C (-31 °F to +185 °F)
<b>Operating Frequency</b>	50–60 Hz
<b>Typical Connection</b>	18" #12 AWG (pre-wired pig tails)
<b>Permissible Operating Humidity (RH)</b>	0 % to 95 % non-condensing
<b>Altitude (max)</b>	4,000 m (13,123 ft)
<b>Degree of Protection</b>	IP20 (built-in)
<b>Housing Material</b>	Polycarbonate NEMA 4X – Lid ultrasonically sealed
<b>Thermal Protection</b>	Yes
<b>Operating State/Fault Indication</b>	1 Green LED (for each phase)
<b>Product Dimensions</b>	<b>H</b> 2.75"; <b>W</b> 4.25"; <b>D</b> 2.41"
<b>Product Weight</b>	0.5 lb
<b>Package Dimensions</b>	4-3/8" x 3-1/2" x 9-1/2"
<b>Package Weight</b>	0.7 lb

### Certification & Compliance

<b>cULus</b>	UL 1449, 5th Edition; E320116
<b>RoHS</b>	RoHS 2 Directive 2011/65/EU; Directive (EU) 2015/863
<b>REACH</b>	Regulation (EC) No 1907/2006

### Part Numbering System

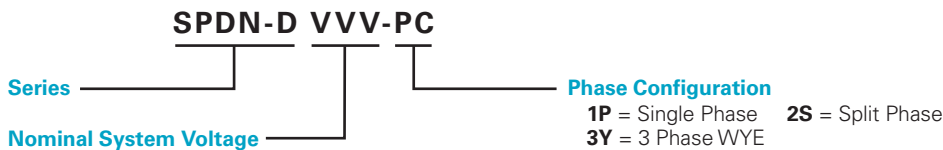

### Ordering Information

ORDERING NUMBER	NOMINAL SYSTEM VOLTAGE	PHASE CONFIGURATION	MAXIMUM CONTINUOUS AC OPERATING VOLTAGE (MCOV)	VOLTAGE PROTECTION RATING (VPR)			
				L-N	L-G	N-G	L-L
SPDN-D120-1P	120	Single Phase	180	700	1200	600	
SPDN-D120-2S	120/240	Split Phase	180	700	1200	600	1200
SPDN-D120-3Y	208/120	3 Phase WYE	150	600	1000	600	1000
SPDN-D240-1P	240	Single Phase	350	1200	2000	1200	
SPDN-D240-2S	240/480	Split Phase	350	1200	2000	1200	2000
SPDN-D277-3Y	480/277	3 Phase WYE	350	1200	2000	1200	2000

# Surge Protective Devices

## SPDN SERIES DIMENSIONAL DIAGRAMS

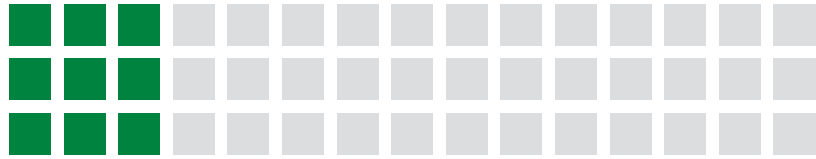

### SPDN-A SERIES

Dimensions Inches [mm]

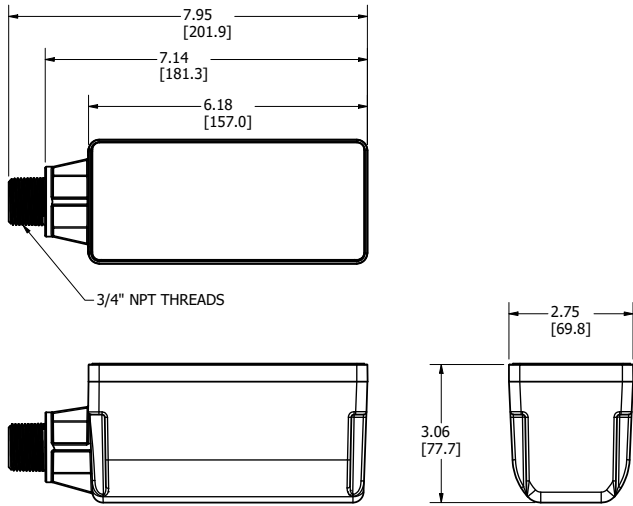

### SPDN-B SERIES

Dimensions Inches [mm]

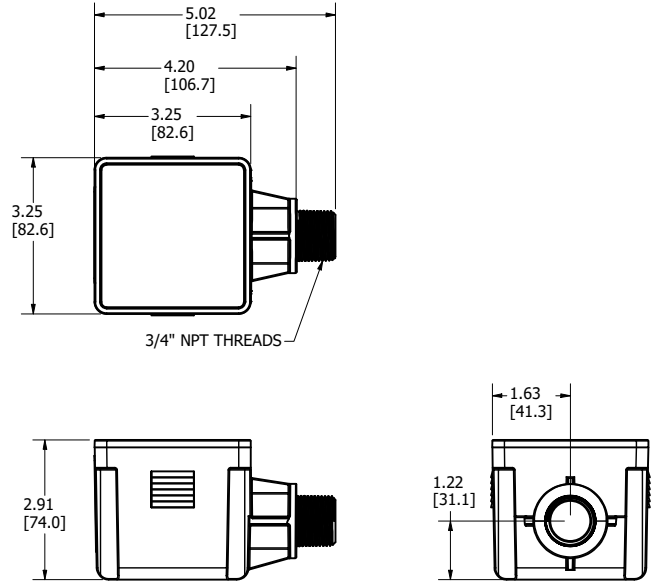

### SPDN-C SERIES

Dimensions Inches [mm]

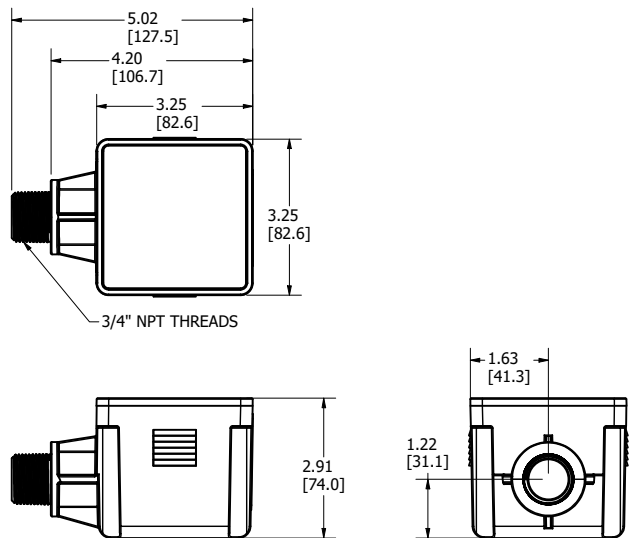

### SPDN-D SERIES

Dimensions Inches [mm]

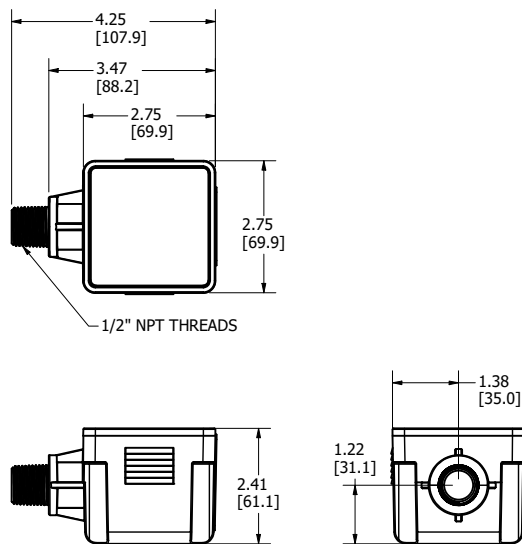

# Surge Protective Devices

## SPDN SERIES CROSS-REFERENCE GUIDE



### SPDN-A and SPDN-B Series

Series/Model	Littelfuse SPDN-A	Littelfuse SPDN-B	Schneider/ASCO 425	Eaton SPC	Mersen STXP	Southern Tier 450	Ilco/SSI XE
<b>Surge Current Ratings (per mode)</b>	65 kA	65 kA	50 kA	100 kA	50 kA	25 kA	100 kA
<b>SPD Technology</b>	Pill Stack	Pill Stack	TPMOV	TPMOV	TPMOV	PTMOV	TPMOV
<b>Nominal Discharge Current (8/20)</b>	20 kA	20 kA	20 kA	20 kA	20 kA	20 kA	20 kA
<b>UL 1449 SPD Type</b>	Type 1 or 2	Type 1	Type 1	Type 1 or 2	Type 1	Type 2	Type 1 or Type 2
<b>MCOV (120 V model)</b>	150 V	150 V	150 V	150 V	150 V	150 V	150 V
<b>VPR (L-N 120 V model)</b>	700 V	700 V	700 V	700 V	700 V	700 V	700 V
<b>Modes of Protection</b>	All	All	All	All	All	All	All
<b>SCCR</b>	200 kA	200 kA	200 kA	200 kA	200 kA	200 kA	200 kA
<b>Connection Type</b>	Wired	Wired	Wired	Wired	Wired	Wired	Wired
<b>Encloser Type (standard)</b>	NEMA 4X	NEMA 4X	NEMA 4X	NEMA 4X	NEMA 4X	NEMA 4X	NEMA 4X
<b>Indicator Lights</b>	1 per phase	1 per phase	1 per phase	1 per phase	2 LEDs per phase	Single	1 per phase
<b>Audible Alarm</b>	Yes	Yes	Yes	Optional	Yes	No	Optional
<b>Form C Dry Contacts</b>	Yes	Yes	Yes	Optional	Yes	Yes	Optional
<b>EMI/RFI Filtering</b>	Optional	No	No	Optional	No	Yes	Optional
<b>Ground Reference Monitoring</b>	N-G Voltage > 20 V Detected	No	No	No	No	No	No



### SPDN-C and SPDN-D Series

Series/Model	Littelfuse SPDN-C	Littelfuse SPDN-D	Schneider/ASCO 420	Mersen STXR	Ilco/SSI SE	Citel M50
<b>Surge Current Ratings (per mode)</b>	50 kA	50 kA	50 kA	50 kA	100 kA	50 kA
<b>SPD Technology</b>	Pill Stack	Pill Stack	TPMOV	TPMOV	TPMOV	TMOV + GSG
<b>Nominal Discharge Current (8/20)</b>	20 kA	20 kA	20 kA	20 kA	20 kA	20 kA
<b>UL 1449 SPD Type</b>	Type 1	Type 1	Type 1	Type 1	Type 1 or Type 2	Type 1 or Type 2
<b>MCOV (120 V model)</b>	150 V	150 V	150 V	150 V	150 V	150 V
<b>VPR (L-N 120 V model)</b>	600 V	600 V	600 V	700 V	700 V	700 V
<b>Modes of Protection</b>	Reduced	Reduced	Reduced	Reduced	Reduced	Reduced
<b>SCCR</b>	200 kA	200 kA	200 kA	200 kA	200 kA	200 kA
<b>Connection Type</b>	Wired	Wired	Wired	Wired	Wired	Wired
<b>Encloser Type (standard)</b>	NEMA 4X	NEMA 4X	NEMA 4X	NEMA 4X	NEMA 4X	NEMA 6
<b>Indicator Lights</b>	1 per phase	1 per phase	Single	Single	Single	1 per phase
<b>Audible Alarm</b>	Yes	No	Yes	Optional	Optional	Yes
<b>Form C Dry Contacts</b>	Yes	No	Yes	Optional	Optional	No
<b>EMI/RFI Filtering</b>	No	No	No	No	Optional	Optional



# LOCAL RESOURCES FOR A **GLOBAL** MARKET

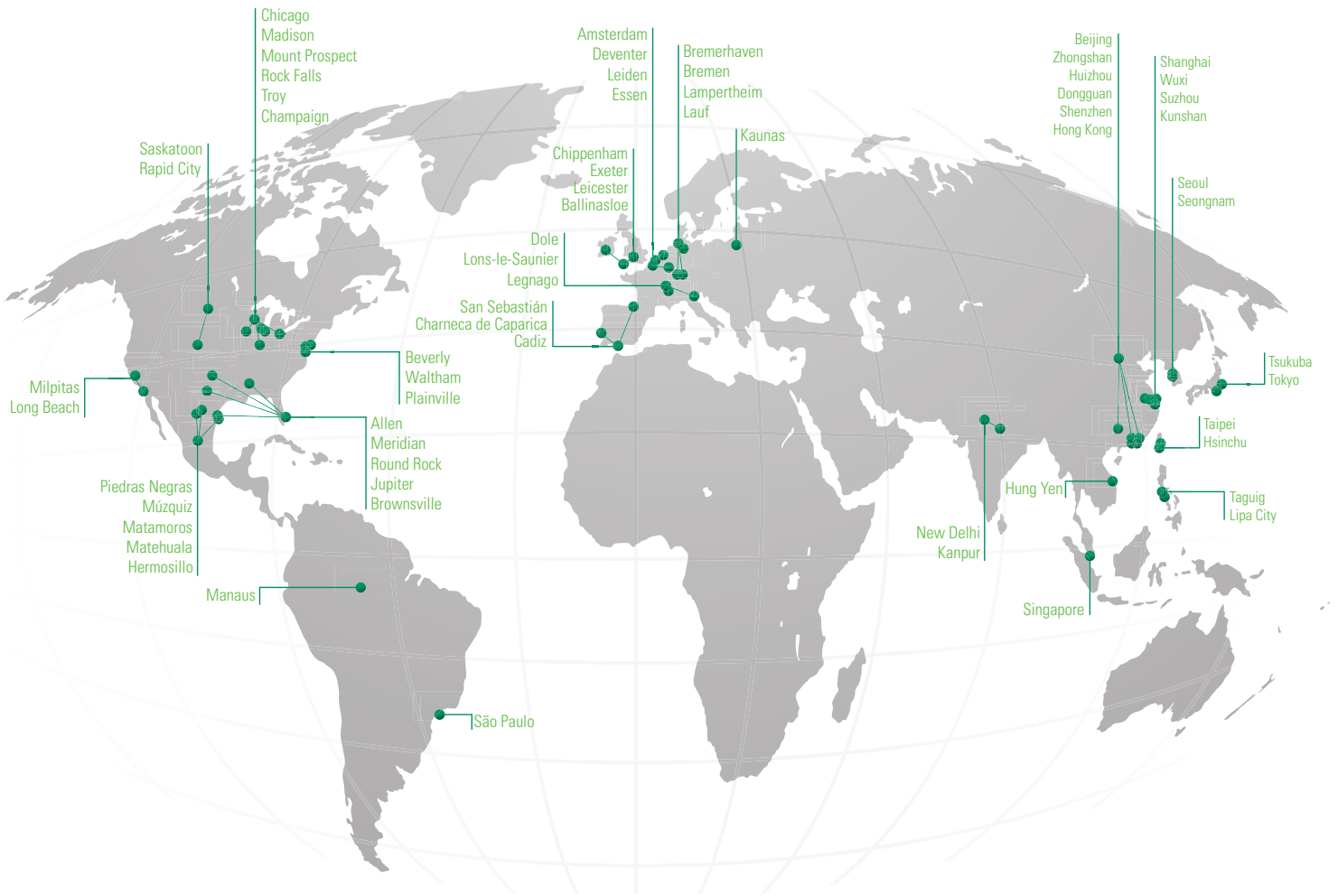

## Your Partner for Dependable Protection, Safety & Control

The Industrial division of Littelfuse delivers vital products to address customer needs for protection, safe control and distribution of electrical power in industrial applications.

In addition to our surge protective devices, our product portfolio includes a comprehensive line of fuses, fuse holders, protection relays, temperature sensors, and timers to minimize electrical safety hazards, limit equipment damage, improve productivity, and safeguard personnel from injury due to electrical faults.



### Fuses, Blocks, Holders & Panels

- Custom OEM Products
- Distributor & Splicer Blocks
- Electrical Switch Panels
- Fuse Blocks & Holders
- Medium Voltage Fuses
- POWR-SPEED® Fuses
- Solar Fuses
- UL Class Fuses
- 10 x 38 mm Fuses
- Battery Protection Fuses



### Protection Relays, Controls & Sensors

- Arc-Flash Protection Relays
- Feeder Protection
- Ground-Check Relays
- Ground-Fault Protection Relays
- Industrial Shock Block® GFCI
- Motor & Pump Protection
- Resistance Grounding/Monitoring
- Single-Function Relays
- Timers & Flashers
- Temperature Sensors

For a comprehensive list of products, visit [Littelfuse.com](http://Littelfuse.com)



**North America**

**Littelfuse World Headquarters**  
 8755 West Higgins Road, Suite 500  
 Chicago, IL 60631, USA

**Technical Support:**  
 Tel: +1-800-TEC-FUSE  
 E-mail: [techline@littelfuse.com](mailto:techline@littelfuse.com)

**Littelfuse SymCom**

1241 Concourse Drive  
 Rapid City, SD 57703, USA

**Customer Service:**  
 Tel: +1-800-227-0029  
 E-mail: [PG\\_CSG@littelfuse.com](mailto:PG_CSG@littelfuse.com)

**Littelfuse Startco**

140 – 15 Innovation Boulevard  
 (The Galleria Building)  
 Saskatoon, SK S7N 2X8, Canada  
 Tel: +1-306-373-5505

**Hartland Controls** now part of **Littelfuse**

807 Antec Road  
 Rock Falls, IL 61071, USA  
 Tel: +1-815-626-5170

**Asia**

**Littelfuse**  
 Unit 1604B Desay Building,  
 Gaoxin Nanyi Ave.  
 Hi-Tech Industrial Park  
 Nshan District  
 Shenzhen, 518057, China  
 +86 755 8207 0760

**Europe**

**Littelfuse**  
 Julius-Bamberger-Str. 8a  
 Bremen, D-28279, Germany  
 +49 421 82 87 3 147



Littelfuse products are certified to many standards around the world. To check certifications on specific components, please refer to the specific product datasheet on [Littelfuse.com](http://Littelfuse.com).

**Warranty** – Visit [www.littelfuse.com/warranty](http://www.littelfuse.com/warranty) for details.

**Disclaimer Notice** – Information furnished is believed to be accurate and reliable. However, users should independently evaluate the suitability of and test each product selected for their own applications. Littelfuse products are not designed for, and may not be used in, all applications. Read complete Disclaimer Notice at [www.littelfuse.com/product-disclaimer](http://www.littelfuse.com/product-disclaimer).