

MODEL 777-P2 777-575-P2 ELECTRONIC OVERLOAD RELAY



TABLE OF CONTENTS

<u>CONNECTIONS</u>	3
<u>PROGRAMMING</u>	7
<u>PROGRAMMABLE PARAMETERS</u>	8
<u>OPERATION</u>	11
<u>PROGRAMMING EXAMPLES</u>	12
<u>SYSTEM DISPLAY</u>	13
<u>TROUBLESHOOTING</u>	14
<u>CLEARING LAST FAULT</u>	16
<u>TAMPER GUARD</u>	16
<u>GROUND FAULT TESTING PROCEDURE</u>	17
<u>777-P2 SPECIFICATIONS</u>	18

DANGER!



HAZARDOUS VOLTAGES MAY BE PRESENT DURING INSTALLATION.

Electrical shock can cause death or serious injury.

Installation should be done by qualified personnel following all national, state and local electrical codes.



**BE SURE POWER IS DISCONNECTED PRIOR TO INSTALLATION!
FOLLOW NATIONAL, STATE AND LOCAL CODES.
READ THESE INSTRUCTIONS ENTIRELY BEFORE INSTALLATION.**

WARNING!

Hazardous Voltage. Failure to follow these instructions can result in death, serious injury, or equipment damage.

Power must be disconnected prior to attaching and/or using the battery cable.

Damage to the device or serious injury may occur if the battery programming feature is used while power is applied. Always follow proper safety procedures for removing and securing the power source before connecting the battery cable.

The battery cable cannot be used when power is applied to the device. To program the device when it is powered, the user must utilize a network programming option.

The 777-P2 is an electronic overload relay that is fully programmable for customized protection. The 777-P2 is designed to protect 3-phase systems with operating voltages of 200-480VAC (500-600VAC for the Model 777-575-P2). The output relay is a Form C contact, which can control a contactor or other device within the output relay contact rating.

The 777-P2 can be safely programmed prior to installation by supplying power with a 9V battery. See Figure 4 in the PROGRAMMING section. DO NOT connect the battery to the unit when line voltage is present. The 777-P2 **cannot** be tested for proper operation or communications using a 9V battery. For testing purposes, 3-phase power must be used with a minimum voltage of 200VAC (500VAC for the Model 777-575-P2). Follow all safety warnings when dealing with hazardous voltages.

CONNECTIONS

1. Disconnect power and verify line and control power are off.
2. Using the four corner tabs or the DIN rail mount, install the 777-P2 directly above or below the contactor. To mount on a DIN rail, hook the top clips first then apply downward pressure until the lower clips snap onto the rail.
3. a) For amperages from 20-90 amps, insert the motor conductors through the holes marked A, B, and C. Ensure the motor phase conductors correspond with the round hole designations, i.e. the A phase conductor should go through the round hole marked "A". See Figure 1 for a typical wiring diagram.

b) For amperages less than 20 amps, loop the motor conductors according to Table 1. Figure 2 shows an example of the looping required for current ranging from 12-20 amps (MULT=2).

c) For amperages greater than 90 amps, external CTs (current transformers) are required. Littelfuse recommends using CTs with terminal connections for easier installation. All CT secondaries must make five passes through the round holes on the MotorSaver® Plus. See Figure 3 for a typical wiring diagram using external CTs.

NOTE: Pay close attention to the wiring diagrams to eliminate any errors when communicating power factor information over a network. The L2 phase conductor must pass through the B current measurement hole for proper operation.

4. Connect the 3-phase power from the line side of the contactor to L1, L2, and L3 terminals using 12-18 AWG copper wire. These should be tightened to 7 in.-lbs., max.
5. Connect the control circuit wires to the appropriate terminals. The relay is designed for fail-safe operation; the NO (normally open) contact should be in series with the coil on the contactor for motor control (see Figure 1). For alarm circuits, the NC (normally closed) contact is in series with the alarm circuitry.

Recommended Full Load Amps	OC Range (Amps)	UC Range (Amps)	# of Passes through each Window	MULT (CT Ratio)
2-2.5	2-10	0, 1-9.8	10	10
2.5-3	2.2-11.1	0, 1.1-10.8	9	9
3-3.5	2.5-12.5	0, 1.2-12.2	8	8
3.5-4	2.8-14.3	0, 1.4-14	7	7
4-5	3.3-16.7	0, 1.6-16.3	6	6
5-6	4-20.1	0, 2-19.6	5	5
6-8	5-25.1	0, 2.5-24.5	4	4
8-12	6.6-33.5	0, 3.3-32.6	3	3
12-20	10-50.3	0, 5-49	2	2
20-90	20-100	0, 10-98	1	1
80-110	80-140	0, 40-140	5	100 (100:5)
110-160	120-210	0, 60-210	5	150 (150:5)
160-220	160-280	0, 80-280	5	200 (200:5)
220-320	240-420	0, 120-420	5	300 (300:5)
320-420	320-560	0, 160-560	5	400 (400:5)
400-520	400-700	0, 200-700	5	500 (500:5)
480-600	480-840	0, 240-840	5	600 (600:5)
540-700	560-980	0, 280-980	5	700 (700:5)
560-800	640-992/FFF	0, 320-992/FFF	5	800 (800:5)

Table 1: Wiring Configuration Based on Motor Full Load Amps

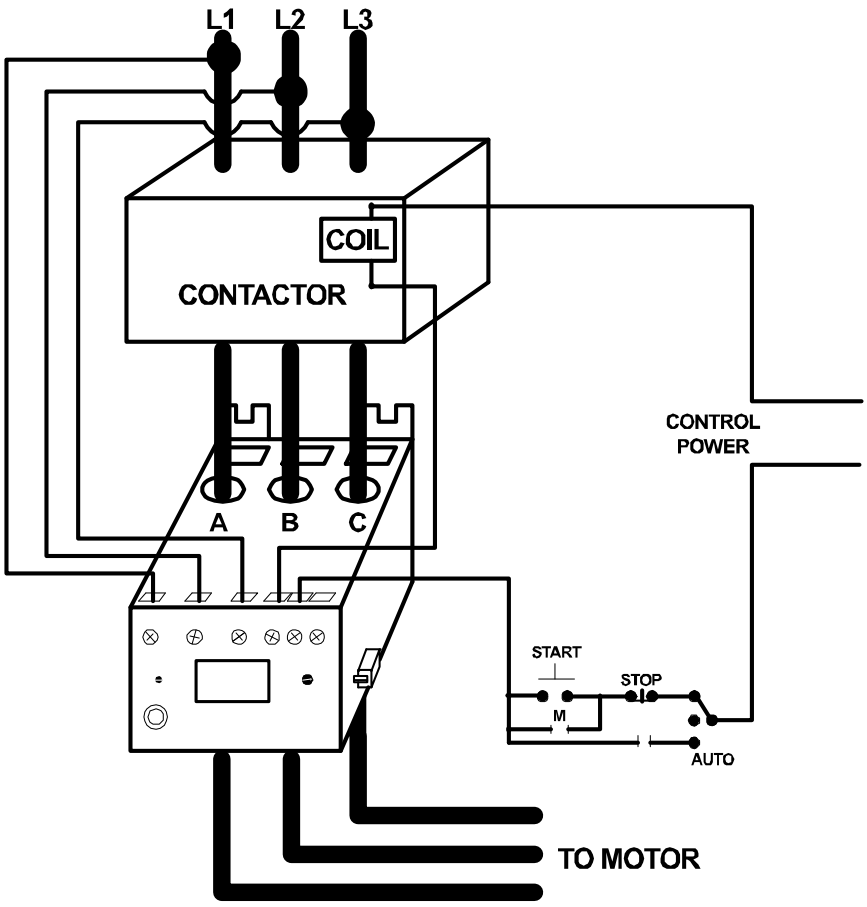

Figure 1: Typical Wiring Diagram

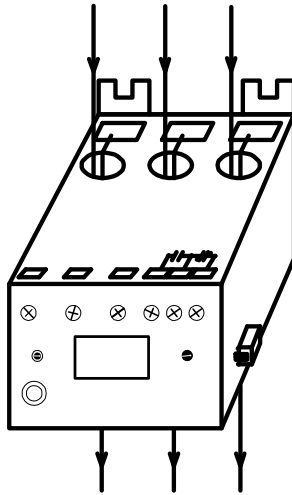

Figure 2: Looping Example for 12-20A, MULT = 2

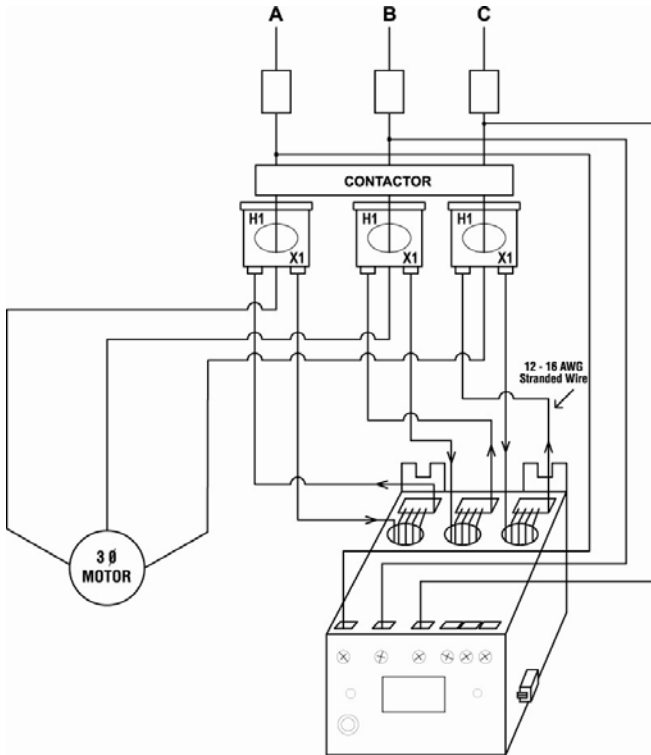

Figure 3: Typical Wiring Using External CTs¹

¹ All CTs must face the same direction, and all CT secondaries must be wired identically, i.e. all X1 terminals enter the main (round) window and return to H1 terminal after exiting the loop conductor window (rectangle). Every CT secondary must make 5 passes through the corresponding main conductor window. Littelfuse recommends using CTs with terminals to simplify installation.

PROGRAMMING

To program prior to installation, connect the 9V battery cable to the pins on the left side of the unit (when looking at the display), and then attach a standard 9V battery to the cable. See Figure 4. The 9V battery cable is keyed for proper installation. If the cable is connected improperly, the 777-P2 will not power the display. DO NOT connect the battery when line voltage is present. The 777-P2 **cannot** be tested for proper operation or communications using a 9V battery. For testing purposes, 3-phase power must be used with a minimum voltage of 200VAC (500VAC for the Model 777-575-P2). Follow all safety warnings when dealing with hazardous voltages.

1. Rotate the MODE SELECT switch to the parameter to be programmed. It is recommended that LV be programmed first.
2. Press and hold the RESET/PROGRAM button.
3. While holding the RESET/PROGRAM button, rotate the DISPLAY/PROGRAM knob until the proper setting for the parameter that is being programmed is displayed.
4. Release the RESET/PROGRAM button. This stores the new parameter in the nonvolatile memory. If the number changes back to what it was before programming, then the tamper guard is on and will need to be unlocked before programming can be completed (see Tamper Guard).
5. Move clockwise through the positions to complete the process. Continue steps 1-4 until all parameters are programmed.



Figure 4: Proper Position of the Battery Cable

PROGRAMMABLE PARAMETERS

The following settings **MUST** be programmed by the user in order to provide proper protection for the application. Settings vary by situation and application and should be selected and tested for each unique installation. All parameters are actual values except for the VUB and CUB settings; these are programmed as percentages. The range each parameter can be programmed is found in the electrical specifications table. See Programming Examples for sample setup instructions. Failure to program all setpoints could result in nuisance tripping or prevent the device from protecting the motor. Always use the proper CTs for the motor full load amperage (FLA).

LV/HV - Low Voltage/High Voltage. The recommended settings for LV (low voltage) and HV (high voltage) according to the NEMA MG1 standard are $\pm 10\%$ of the motor's nameplate voltage. Generally, the motor manufacturer should be contacted to verify these limits. High and low voltage trips are based on average voltage measured. Never set LV higher than HV.

Example: Nameplate voltage = 230 V
LV = $90\% \times 230 = 207$ V
HV = $110\% \times 230 = 253$ V

VUB - Voltage Unbalance. The NEMA MG1 standard says a motor should not be operated above a 1% voltage unbalance without derating the motor. Most utility supplied power sources have a difficult time sustaining a 1% VUB. The motor manufacturer should be consulted for an exact VUB setting. Setting VUB to 999 will disable voltage unbalance protection, but will not disable voltage single-phase protection. Voltage unbalance is calculated as follows:

$\% \text{Voltage Unbalance} = [(\text{Maximum deviation from the average}) / \text{Average}] \times 100\%$

Example: Measured line-line voltages = 203, 210, and 212. The average = $(203+210+212)/3 = 208.3$. The maximum deviation from the average is the greatest difference between the average voltage (208.3) and any one voltage reading: $212 - 208.3 = 3.7$, $210 - 208.3 = 1.7$ and $208.3 - 203 = 5.3$. The maximum deviation from the average is 5.3, thus voltage unbalance = $5.3/208.3 \times 100 = 2.5\%$.

MULT - MULT (multiplier) setting is found in Table 1. The MULT setting is determined by the number of passes of the motor leads or the size of external CTs and the full load amps of the motor the unit will be monitoring. MULT sets the trip point range for undercurrent, overcurrent and ground fault current faults. Set MULT first, then set UC, OC and GF.

OC - Overcurrent. Is typically set to the service factor amperage (SFA) of the motor or 100-135% of motor full-load amps (FLA), which are determined by the motor manufacturer. The value must be higher than UC. If any one leg exceeds the OC setting, the 777-P2 will trip according to the Trip Class (TC) settings.

NOTE: When using external CTs, do not set OC greater than the thermal rating of the CTs

UC - Undercurrent. Is most commonly set to 80% of the full-load amperage (FLA) of the motor. This is usually adequate for protection of loss of load for many pumps and motors, including submersibles. If the motor is drawing less than full load amperage, then the UC may be set lower than 80% of FLA for adequate protection. Centrifugal/booster pumps may have to be set to something higher than 80% of FLA for adequate protection. UC can be set to 0 if UC protection is not desired. The 777-P2 examines average current to determine if an undercurrent trip condition exists. The value must be lower than OC

CUB - Current Unbalance. Littelfuse recommends contacting the motor manufacturer for a specific setting. Current unbalance is calculated the same way voltage unbalance is calculated (see formula above). Setting CUB to 999 will disable current unbalance and current single-phase protection.

TC - Trip Class. Determines how quickly the 777-P2 will trip when an overcurrent (overload) condition is detected. TC is a dual-function setting—both a thermal trip class (NEMA standard) and a linear trip delay (in seconds) can be set.

While the standard trip classes are 5, 10, 15, 20, and 30, TC can be set from 2–60, with or without jam protection. The trip class setpoint is the time in seconds that the device will take to trip when any phase current is greater than or equal to 600% of the OC setpoint. These additional “non-standard” trip classes allow the unit to follow a trip curve in-between the “standard” trip class curves shown in Figure 5.

Trip classes 2–60 can be set from approximately the 7 o'clock to 10 o'clock position with the DISPLAY/PROGRAM knob. Trip classes J02–J60, which include jam protection, can be set from approximately the 10 o'clock to 1 o'clock position. This additional jam protection feature, when enabled, is initiated 1 minute after the motor starts and provides a 2-second trip delay for motors exceeding 400% of the OC setting.

The linear overcurrent trip delay can be set from approximately the 1 o'clock to 5 o'clock position from 0–60 seconds (L00–L60) or to “oFF.” If TC is set to L00, the 777-P2 will trip off within 1 second after motor current reaches the OC setpoint. If both trip class and linear trip delay settings are programmed, the 777-P2 will follow the faster trip time. For example, TC is set to J15 and L20, and the amperage is 200% of the OC setting. Following the trip class 15 curve, the 777-P2 will trip off in approximately 100 seconds. Thus the 777-P2 will follow the linear trip delay setting, because it is faster, and will trip off in 20 seconds.

The motor manufacturer should be contacted for an exact TC setting. Table 3 describes the trip classes, and Figure 5 shows the trip class curves.

RD1 - Restart Delay One. Rapid-cycle timer, in seconds (default). The purpose of this timer is to provide protection against short cycling and to allow adequate cool down time between motor starts. This timer is initiated when power is first applied to the unit. If no voltage fault conditions exist, the output relay will energize (the NO will close and the NC will open) as soon as RD1 timer expires. In most cases, this is set to 20-30 seconds. This should provide adequate protection for successive power outages or short cycling caused by other motor controls. This timer is also initiated when motor current goes to zero. Setting RD1 to zero will turn off this feature and ensure that when an alarm circuit is used, an alarm will sound only when there is a fault or power to the unit is lost.

RD2 - Restart Delay Two. Referred to as a motor cool-down timer, in minutes (default). RD2 is used to restart the motor after a trip due to a current unbalance, current single-phasing, or an overcurrent condition. A setting of 5-10 minutes will give most motors adequate time to cool down after an overcurrent condition. The motor manufacturer should be contacted for an exact value.

RD3 - Restart Delay Three. This timer, in minutes (default), only initiates after an undercurrent trip and is referred to as a dry-well recovery timer in pumping applications. This is set according to the time it takes for the well to recharge after pumping dry. This setting varies widely by application and there is no typical setting. RD3 can be set from 2-500 minutes or to A to enable the automatic Dry-Well Recovery Calculator.

The Automatic Dry-Well Recovery Calculator allows the 777-P2 to automatically select a restart delay based on the run time of the last run cycle before tripping on an undercurrent fault. Table 2 shows the next restart delay vs. run time. In general, a longer run time produces a shorter restart delay. This feature allows the 777-P2 to optimize running and rest times automatically.

Run Time	Next Restart Delay (minutes)	Starts/Hr
> 1Hr	6	10
30 min.- 59.99 min.	15	4
15 min.- 29.99 min.	30	2
< 15 min.	60	1

TABLE 2: Automatic Dry-Well Recovery Timer

#RU/ADDR - Restart Attempts (undercurrent)/Address. The #RU/ADDR is a dual-function setting. #RU settings are displayed and selected by turning the DISPLAY/PROGRAM dial from approximately the 7 o'clock to 12 o'clock position. ADDR settings are displayed and selected by turning the DISPLAY/PROGRAM dial from approximately the 12 o'clock to 5 o'clock position.

#RU is the number of restarts the 777-P2 will attempt after an undercurrent fault before the unit locks out and requires a manual reset. #RU can be set to 0, 1, 2, 3, 4, or A. This counter is cleared one minute after restarting if the 777-P2 does not trip again on undercurrent.

If #RU is set to "0", the 777-P2 will require manual resetting after all undercurrent faults. If #RU is set to "A", the 777-P2 will always automatically restart after undercurrent faults, once the RD3 timer expires.

ADDR is the RS-485 address of the 777-P2 and is only used when communicating with any external communication device. The address can be set from A01–A99.

#RF/COM - Restart Attempts (other faults)/ Communications Settings. The #RF settings are displayed and selected by turning the DISPLAY/PROGRAM dial from approximately the 7 o'clock to 12 o'clock position. COM settings are displayed and selected by turning the DISPLAY/PROGRAM dial from approximately the 12 o'clock to 5 o'clock position.

#RF is the number of restarts the 777-P2 will attempt after current unbalance or current single-phase faults before the unit locks out and requires a manual reset. This counter will be cleared one minute after start-up if the unit does not trip again for the same fault condition. Available settings are 0, 1, 2, 3, 4 and A, or to include overcurrent faults, #RF can be set to oc1, oc2, oc3, oc4 or ocA.

If #RF is set to "0", the 777-P2 will require manual resetting after all current unbalance, current single-phase and overcurrent faults.

If #RF is set to "A", the 777-P2 will always restart automatically after current unbalance and current single-phase faults, once the RD2 timer expires. Overcurrent faults will require a manual reset.

If #RF is set to "ocA", the 777-P2 will always restart automatically after current unbalance, current single-phase and overcurrent faults, once the RD2 timer expires.

COM determines the baud rate, even/odd parity, and stop bit. COM can be set to C00-C07. C00 and C04 are duplicates provided for backward compatibility.

- C00 = 9600 baud, No parity, and 1 stop bit
- C01 = 9600 baud, Odd parity, and 1 stop bit
- C02 = 9600 baud, No parity, and 1 stop bit
- C03 = 9600 baud, Even parity, and 1 stop bit
- C04 = 19200 baud, No parity, and 1 stop bit
- C05 = 19200 baud, Odd parity, and 1 stop bit
- C06 = 19200 baud, No parity, and 1 stop bit
- C07 = 19200 baud, Even parity, and 1 stop bit

UCTD - Undercurrent Trip Delay. The length of time, in seconds (default), the unit will allow the motor to run in an undercurrent situation before de-energizing its relay. Typically, UCTD is set to 2-4 seconds to allow for motor to reach full load.

GF - Ground Fault. The maximum allowable current that can flow to ground before the 777-P2 de-energizes its relay. This is a residual, class II ground fault system and should not be used for personnel safety. A typical setting for GF is 10-20% of motor FLA (in amps). GF may be set to oFF if this feature is not desired. The GF test procedure in this installation instruction manual must be conducted before the device is brought online.

OPERATION

The relay operation of the Model 777-P2 is designed to be fail-safe. This means when the voltage is within the programmed limits, the relay will energize—the NO contact will close and the NC contact will open. When the unit loses power or senses a fault condition, the relay will de-energize and contacts will return to their original state. Once the unit has been installed and programmed, the unit is ready to operate. Turn MODE SELECT to the RUN position. The display will show “run” alternating with a number (the number displayed will be the number corresponding to where the DISPLAY/PROGRAM knob is pointed). It will do this for the restart delay time programmed into RD1. Once the timer expires, the relay will energize—the NO contact will close and the NC contact will open. If something other than this is displayed, see the troubleshooting section for more information. If MODE SELECT is taken out of RUN, the 777-P2’s relay will de-energize.

Trip Class	Application Description
5	Small fractional horsepower motors where acceleration times are almost instantaneous or where extremely quick trip times are required
10	(Fast Trip) Hermetic refrigerant motors, compressors, submersible pumps and general-purpose motors that reach rated speed in less than 4 seconds
15	Specialized applications
20	(Standard Trip) Most NEMA-rated general-purpose motors will be protected by this setting
30	(Slow Trip) Motors with long acceleration times (>10 seconds) or high inertia loads
J Prefix (Jam Protection)	Programming any of the trip classes with the J prefix will enable jam protection. This additional protection is enabled 1 minute after the motor starts and provides a 2 second trip time for motors exceeding 400% of the OC setting
Non-Standard Trip Classes	Trip time in seconds when any phase current is 600% of OC. Time is approximately 90% of the TC setting

Table 3: Trip Class Descriptions

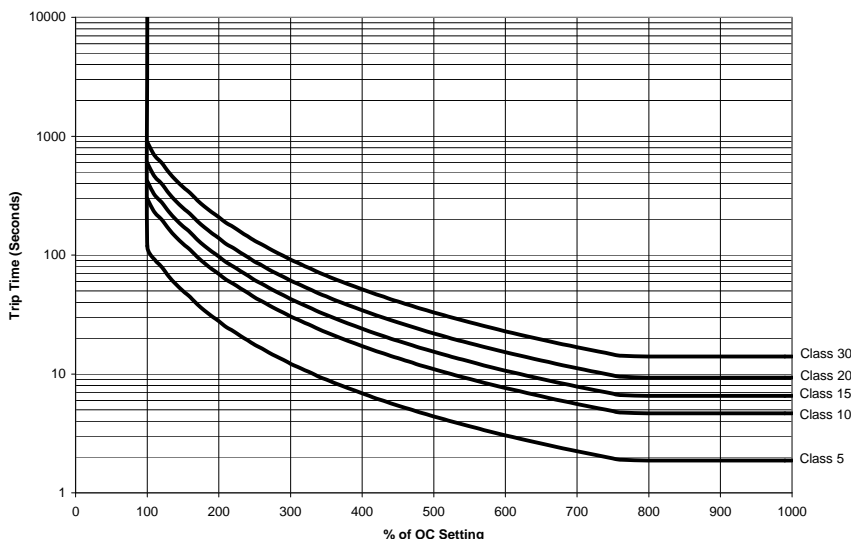

Figure 5: Overload Trip Curves

PROGRAMMING EXAMPLES

NOTE: Since no network communications are connected in these examples there are no setting changes needed for ADDR or COM

Example #1

Motor to be protected: 3-phase, 460 Volt, 25 hp air compressor with a full load amperage rating of 34A and a service factor of 1.1 or max amps at 37.4. Use the following calculations and reasoning to determine the appropriate settings for this application.

- LV- $460 \times 0.90 = 414$
- HV- $460 \times 1.10 = 506$
- VUB- Manufacturer suggests 3
- MULT- $MULT=1$ from Table 1
- OC- Service Factor Amperage = 37.4
- UC- $FLA \times 0.80 = 34A \times 0.80 = 27.2$
- CUB- Manufacturer suggests 5
- TC- From Table 3, general purpose motor = 20
Linear Trip = Off
- RD1- Since this compressor takes about 10 seconds to bleed off excess pressure after a shutdown, setting RD1 = 15 will allow the compressor to unload before being restarted.
- RD2- Because the motor may be hot from running in an unbalance or single-phase condition, a motor cool-down time of 10 minutes should be appropriate, RD2 = 10.
- RD3/#RU- Because an undercurrent would signal a serious problem in this application (a broken shaft or belt), #RU should be set to 0 for a manual reset. Therefore, RD3 does not have any function and no timer setting is needed.
- #RF- Because an overcurrent (overload) fault signals a serious problem in this application (e.g., worn bearings), "oc" should not be included in the #RF setting so that a manual reset after an overcurrent fault is required. A #RF=1 will give the system 1 chance to recover from a current unbalance or current single-phasing problem before manual reset is required.
- UCTD- Setting UCTD = 5 will allow the compressor to reach normal operation and not allow the motor to run too long in a failure mode.
- GF- A ground fault setting of 15% of full load amps may likely indicate that the motor should be evaluated for repair or replacement. Therefore, $GF = 34A \times 0.15 = 5.1$.

Example #2

Motor to be protected: 3-phase, 230 Volt, 5 hp submersible pump with a full load amperage of 15.9A and a service factor of 1.15 or max amps at 18.3. Use the following calculations and reasoning to determine the appropriate settings for this application.

- LV- $230 \times 0.90 = 207$
- HV- $230 \times 1.10 = 253$
- VUB- Manufacturer suggests 3
- MULT- $MULT=2$ from Table 1
- OC- Service Factor Amperage = 18.3
- UC- $FLA \times 0.80 = 15.9 \times 0.80 = 12.7$
- CUB- Manufacturer suggests 5
- TC- From Table 3, for this (and most) submersible pump, TC = 10 (fast trip)
Linear Trip = Off
- RD1- To protect the pump from rapid cycling, RD1 = 60
- RD2- Since the motor is small and submerged in water, the motor will generally cool down quickly. RD2=5

- RD3- The well history shows that it will fully recover in 2 hours. RD3 = 120
- #RU- In this application, we know that the well will eventually recharge itself, #RU = A (Automatic).
- #RF- This well is known for sand to jam the impeller, therefore "oc" should be included so that the pump will attempt to automatically restart after an overloaded condition. History shows that 2 or 3 starts and stops usually clears the sand out of the impeller. #RF= oc2 or oc3.
- UCTD- This well may become air locked on startup, but will usually re-prime itself in 5 seconds or less. UCTD = 10
- GF- Because this type of fault indicates the impending failure of the motor and it may take several days to get a new pump and schedule for a driller to remove and replace the pump, GF setting of 10% of full load amperage will give the well owner enough time to prepare for pump replacement. GF = 15.9A x 0.10 = 1.59 (use a setting of 1.6 amps).

SYSTEM DISPLAY

On power up, the 777-P2 will show the current software revision. For example if the software revision is 33.04, the 777-P2 will show 033 followed by 004.

The output display can show one of the following parameters when MODE SELECT is in RUN: L1-L2, L2-L3, and L3-L1 line voltage; %VUB; A, B, and C phase current; %CUB; measured GF current. The display is used for programming the operating parameters of the device and also identifies what caused the unit to de-energize its relay or what is keeping the unit from energizing its relay, and under normal operating conditions, what the last fault was. The last fault can be displayed by pressing and holding the RESET/PROGRAM button while MODE SELECT is in RUN. When the unit trips off or is holding the motor off, the current fault condition will be shown in the display without pressing the button (CAUTION: pressing the reset button at this time will reset the unit). Table 4 lists the fault codes the unit could display.

Displayed Message	Meaning
oc	Tripped on overcurrent
SP	Tripped on current single-phasing or unit won't start because the voltage is single-phased
ub	Tripped on current unbalance or unit won't start because the voltage is unbalanced
uc	Tripped on undercurrent
CF	Tripped on contactor failure (due to faulty contacts or connections on the load side)
GrF	Tripped on ground fault
HI	A high voltage condition exists (won't allow motor to start)
Lo	A low voltage condition exists (won't allow motor to start)
rP	Incoming phases have been reversed, the motor may run backwards if started
oFF	A stop command was issued from a remote source
HPr	Tripped on high power
LPr	Tripped on low power
CLo	Tripped on low control voltage
clr	No previous faults
Pro	Shown when programming using the battery in the RUN position
FFF	Displayed value is greater than 999 (can be due to incorrect MULT setting)

Table 4: Fault Codes

TROUBLESHOOTING

The 777-P2 will display a fault code alternating with a number or with “run” when it has tripped. If the unit is showing a fault code alternating with “run,” it is timing down the restart delay. If the fault code is alternating with a number (voltage reading or zero), the unit will not allow the motor to start because there is a problem with the incoming voltage. If the display is showing just a fault code, the unit is in a manual reset mode. This could be because the number of restarts (#RF, #RU) has expired or is not allowed. If the display reads “oFF,” a stop command was issued through the communications network or a remote monitor.

PROBLEM	SOLUTION
The unit will not start. Display alternates “rP” with the DISPLAY/PROGRAM parameter value.	The voltage inputs are reverse-phased. If this is the initial start-up, swap any two of the leads connected to L1, L2, or L3 on the 777-P2 to correct the problem. If the overload relay has been previously running, the power system has been reverse-phased. Check the phase sequence of the incoming power lines. Note: L1 must be tapped from conductor Phase A, L2 from B, and L3 from C for correct power factor measurements on remote communications.
The unit will not start. Display alternates “SP”, “ub”, “HI”, or “Lo” with the DISPLAY/ PROGRAM parameter value.	The incoming voltage is not within the limits programmed in the VUB, HV, and LV settings. Turn the DISPLAY / PROGRAM knob to read each incoming line voltage value. Correct the incoming power problem and check programmed limits by turning the MODE SELECT knob. Compare incoming values for HV, LV, and VUB to setpoints to verify they are correct.
Display alternates “SP”, “ub”, or “oc” with “run.”	The overload relay has tripped on the fault shown on the display and is timing down RD2 before restarting. No further action is required.
Display alternates “uc” with “run.”	The overload relay has tripped on undercurrent and is counting down RD3 before restarting. If undercurrent is not a normal condition for this installation, check for broken shafts, broken belts, etc.
Display is showing a solid “SP”, “ub”, or “oc.”	The unit has tripped on the fault shown and a manual reset is required because of the programmed setting in #RF. Check the system for problems that would produce the single-phase, overcurrent or current unbalance fault, such as a jam.
Display is showing a solid “uc.”	The unit has tripped on undercurrent and a manual reset is required because of the setting in #RU. Check the system for problems that would produce a loss of load such as a broken belt or a lack of liquid to pump.
Display is showing a solid “CF.”	The unit has tripped on current single-phasing, but was not single-phased by the incoming voltage. Check for damaged contacts or loose or corroded wiring connections.
Display is showing a solid “GrF.”	A ground fault current greater than the programmed GF value has been detected. Check the motor for insulation breakdown. A manual reset is required to clear this message. Press the RESET button to perform a manual reset.
Display alternates “LPr” ² with “RUN”	The overload relay has tripped on low power (LPr) and is timing down RD3 before restarting. If LPr is not a normal condition for this installation, check for loss of liquid, closed valves, broken belts, etc.

PROBLEM	SOLUTION
Display is showing a solid "LPr" ²	The unit has tripped on low power and a manual reset is required because of the setting in #RU. Check the system for problems that would produce a loss of load like a broken belt or a pump is out of liquid. Press the RESET button to perform a manual reset.
Display alternates "HPr" ² with "RUN"	The unit has tripped on high power and is timing down RD2. Check for a high power condition.
Display is showing solid "HPr" ²	The unit has tripped on high power and requires a manual reset because of the setting in #RF. Press the RESET button to perform a manual reset.
Display alternates "CLO" ² with "RUN"	The overload relay has tripped on low control voltage (CLO) and is timing down RD2 before restarting.
Display is showing solid "CLO" ²	The unit has tripped on low control voltage and a manual reset is required because of the setting in #RF. Verify system voltage is correct. Press the RESET button to perform a manual reset.

² LPr, HPr, and CLO are enabled only from a network master via a communications module.

CLEARING LAST FAULT

The last fault stored can be cleared on the 777-P2 by following these steps:

1. Rotate the MODE SELECT switch to GF.
2. Press and hold the RESET/PROGRAM button. Adjust the DISPLAY/PROGRAM knob until "cLr" appears on the display. Release the RESET/PROGRAM button.

To verify the last fault was cleared, place the MODE SELECT switch in the RUN position. Then press and hold the RESET/PROGRAM button; "cLr" should be on the display.

TAMPER GUARD

The 777-P2 setpoints can be locked to protect against unauthorized program changes.

1. Rotate the MODE SELECT switch to GF.
2. Press and hold the RESET button. Adjust the DISPLAY/PROGRAM knob until "Loc" appears on the display.
3. Release the RESET button.
4. Turn MODE SELECT switch to RUN.

The program is now locked, but all settings can be viewed. The unit can be unlocked by following the same steps except adjust the DISPLAY/PROGRAM knob to "unL" in step 2.

GROUND FAULT TESTING PROCEDURE

A ground fault test must be performed before installing the 777-P2 as required by UL1053 and NEC, ANSI/NFPA 70.

1. Disconnect power.
2. Hook up the three line voltages to L1, L2, and L3 as required by the installation instructions.
3. Program the desired parameters into the unit. For test purposes, set MULT to 1 and GF to the minimum allowed setting.
4. Construct the circuit, using an AC power supply. This circuit simulates a ground fault condition by generating a current in one of the phases. Alternate test circuits may be used. The only requirement is the current through the current transformer must be between 115% and 150% of the GF setting and pass through only one CT window.

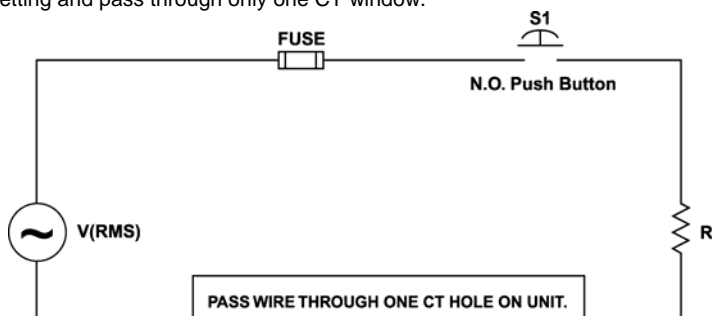

5. The values of V and R will be determined by the current required to generate a GF trip condition: $I = V_{rms}/R$, where $I = 115\%$ of GF setting.
6. Place the unit in the RUN position, apply 3-phase power and allow the NO contact to close.
7. Energize the test circuit by pushing and holding the test pushbutton until the unit trips (within 8.5 seconds). The display should show "GrF" and the NO contacts should be open. Release the NO pushbutton.
8. The results of the test are to be recorded on the test form provided below. The form should be kept by those in charge of the building's electrical installation in order to be available to the authority having jurisdiction.
9. Confirm programmed parameters and proceed with installation instructions.

GROUND FAULT TEST RESULTS*

<u>Date</u>	<u>Performed by</u>	<u>Results</u>	<u>Location</u>
-------------	---------------------	----------------	-----------------

*A copy of this form should be retained by the building's electrical foreman.

777-P2 SPECIFICATIONS

Functional Specifications	
Programmable Operating Points	
LV- Low Voltage Threshold	170–524V (450–649)*
HV- High Voltage Threshold	172–528V (451–660V)*
VUB- Voltage Unbalance Threshold	2-25% or 999 (disable)
MULT- # of Conductors or CT Ratio (XXX:5)	1–10, 100, 150, 200, 300, 400, 500, 600, 700, 800
OC- Overcurrent Threshold **	$(20-100A) \div \text{MULT}$ or 80–140% of CT Primary
UC- Undercurrent Threshold **	$(0, 10-98A) \div \text{MULT}$ or 40–140% of CT Primary
CUB- Current Unbalance Threshold	2–50% or 999 (disable)
TC- Overcurrent Trip Class ³	2-60, J2-J60, L00-L60, oFF
RD1- Rapid Cycle Timer	0-999 seconds
RD2- Restart Delay After All Faults Except Undercurrent (motor cool-down timer)	2–500 minutes
RD3- Restart Delay After Undercurrent (dry-well recovery timer)	2–500 minutes, A (Automatic)
#RU- Number of Restarts After Undercurrent	0, 1, 2, 3, 4, A (Automatic)
ADDR- RS485 Address	A01–A99
#RF-Number of Restarts After All Faults Except Undercurrent ⁴	0, 1, oc1, 2, oc2, 3, oc3, 4, oc4, A, ocA (Automatic)
COM- Communication setting	C00-C07
UCTD- Undercurrent Trip Delay	2–999 seconds
GF- Ground Fault Current Threshold**	$(3-20A) \div \text{MULT}$ or 12-40% of CT Primary or oFF
Trip Times	
Ground Fault Trip Time	Trip time
101%-200% of Setpoint	8 seconds \pm 1 second
201%-300% of Setpoint	4 seconds \pm 1 second
301%-400% of Setpoint	3 seconds \pm 1 second
401% or Greater	2 seconds \pm 1 second
Current Unbalance Trip Times	
<u>% Over Setpoint</u>	<u>Trip time</u>
0%	30 seconds
1%	15 seconds
2%	10 seconds
3%	7.5 seconds
4%	6 seconds
5%	5 seconds
6%	4 seconds
11%	3 seconds
15%	2 seconds
Input Characteristics	
Input Voltage (3-phase)	200–480VAC (Model 777-P2) 500–600VAC (Model 777-575-P2)
Frequency	50/60 Hz
Motor Full Load Amp Range	
3-phase, (looped conductors required)	1–20A
3-phase (direct)	20–90A
3-phase (external CTs required)	80–800A

³ If a “J” is included in the trip class (TC) setting, jam protection is enabled.

⁴ If “oc” is displayed in the #RF setting, overcurrent will be included as an automatic restart after RD2 expires. Otherwise, a manual reset is required after an OC fault.

Output Characteristics	
Output Contact Rating SPDT (Form C)	Pilot duty rating: 480VA @ 240VAC, B300 General purpose: 10A @ 240VAC
Expected Life	
Mechanical	1 x 10 ⁶ operations
Electrical	1 x 10 ⁵ operations at rated load
General Characteristics	
Environmental	
Temperature Range	Ambient Operating: -20° to 70°C (-4° to 158°F) Ambient Storage: -40° to 80°C (-40° to 176°F)
Pollution Degree	3
Class of Protection	IP20 (Finger Safe)
Relative Humidity	10-95%, non-condensing per IEC 68-2-3
Accuracy at 25°C (77°F)	
Voltage	±1%
Current	±3% (<100A direct)
Timing	±0.5 second
Ground Fault	±15% (< 100A)
Repeatability	
Voltage	±0.5% of nominal voltage
Current	±1% (<100A direct)
Maximum Input Power	10 W
Safety Marks	
UL	UL508, UL1053
CE	IEC 60947-1, IEC 60947-5-1
Standards Passed	
Electrostatic Discharge (ESD)	IEC 61000-4-2, Level 3, 6kV contact, 8kV air
Radio Frequency Immunity (RFI), Conducted	IEC 61000-4-6, Level 3 10V
Radio Frequency Immunity (RFI), Radiated	IEC 61000-4-3, Level 3 10V/m
Fast Transient Burst	IEC 61000-4-4, Level 3, 3.5 kV input power
Surge	
IEC	61000-4-5 Level 3, 2kV line-to-line; Level 4, 4kV line-to-ground
ANSI/IEEE	C62.41 Surge and Ring Wave Compliance to a level of 6kV line-to-line
Hi-potential Test	Meets UL508 (2 x rated V +1000V for 1 minute)
Vibration	IEC 68-2-6, 10-55Hz, 1mm peak-to-peak, 2 hours, 3 axis
Shock	IEC 68-2-27, 30g, 3 axis, 11ms duration, half-sine pulse
Mechanical	
Dimensions	3.0" H x 3.6" W x 5.1" D
Terminal Torque	7 in.-lbs.
Enclosure Material	Polycarbonate
Weight	1.2 lbs
Maximum Conductor Size Through 777-P2	0.65" with insulation

NOTE: The 777-P2 can be programmed prior to installation by connecting a 9V battery. Disconnect power prior to using the battery cable and follow all safety warnings.

*575 Volt Model

** Do not program the unit above the thermal rating for the CTs.

For warranty information, please see **Terms and Conditions** at
www.littelfuse.com

Visit www.littelfuse.com for
complete catalog listing. For
technical support call
800-843-8848 or email
techline@littelfuse.com