

INSTALLATION INSTRUCTIONS FOR THE MODEL 777 ELECTRONIC OVERLOAD RELAY

**BE SURE POWER IS DISCONNECTED PRIOR TO INSTALLATION!
FOLLOW NATIONAL, STATE AND LOCAL CODES.
READ THESE INSTRUCTIONS ENTIRELY BEFORE INSTALLATION.**

The Model 777 is a solid-state (electronic) overload relay. It is fully programmable for customized protection and is designed to protect 3-phase systems with operating voltages of 190-480VAC (500-600VAC for the Model 777-575). The output relay is a Form C contact, which can control a contactor or other device within the output relay contact rating. The unit can be programmed prior to installation by applying 120VAC to terminals L1 and L2 (except Model 777-575). The unit cannot be tested for proper operation using this voltage. For testing purposes, 3-phase power needs to be used with a minimum voltage of 190VAC (450VAC for the Model 777-575).

DANGER!



HAZARDOUS VOLTAGES MAY BE PRESENT DURING INSTALLATION.

Electrical shock can cause death or serious injury.

Installation should be done by qualified personnel following all national, state and local electrical codes.



CONNECTIONS

1. Disconnect power and verify power is off.
2. Using the four corner tabs or the DIN rail mount, install the 777 directly above or below the contactor. To use the DIN rail mount, hook the top clip first then apply downward pressure until the lower clip snaps onto the rail.
3. A) For amperages from 26-90 amps, insert the motor conductors through the holes marked A, B, and C. Make certain the conductor through each hole corresponds to the right motor conductor, i.e. the A phase conductor should go through the A round hole. See Figure 1 for a typical wiring diagram.
B) For amperages less than 26 amps, loop the motor conductors according to Table 1. Figure 3 shows an example of the looping required for current ranging from 8.1-12 amps (MULT=3).
C) For amperages greater than 90 amps, external CTs (current transformers) are required. SymCom recommends CTs with terminals be used for ease of installation. All CT secondaries must make five passes through the round holes on the MotorSaver®. See Figure 2 for a typical wiring diagram using external CTs.
NOTE: Pay close attention to this diagram to eliminate any power factor errors when communicating with the device through the RS-485 network.
4. Connect the 3-phase power from the line side of the contactor to L1, L2, and L3 terminals using 12-18 AWG copper wire. These should be tightened to no more than 7 inch lbs.
5. Connect the control circuit wires to the appropriate terminals. The relay is designed for fail-safe operation, thus the NO (normally open) contact should be in series with the coil on the contactor for motor control (see Figure 1). For alarm circuits, the NC (normally closed) contact is in series with the alarm circuitry.



2880 North Plaza Drive
Rapid City, SD 57702 · (800) 843-8848

Recommended Full Load Amps	OC Range (Amps)	UC Range (Amps)	# of Passes through each Window	MULT (CT Ratio)
2-2.5	2-10	0, 1-9.8	10	10
2.5-3	2.22-11.1	0, 1.11-10.8	9	9
3-3.5	2.5-12.5	0, 1.25-12.2	8	8
3.5-4	2.85-14.2	0, 1.42-14	7	7
4-5	3.33-16.6	0, 1.66-16.3	6	6
5-6	4-20	0, 2-19.6	5	5
6-8	5-25	0, 2.5-24.5	4	4
8-12	6.66-33.3	0, 3.33-32.6	3	3
12-25	10-50	0, 5-49	2	2
25-90	20-100	0, 10-98	1	1
80-110	80-140	0, 40-120	5	100 (100:5)
110-160	120-210	0, 60-180	5	150 (150:5)
160-220	160-280	0, 80-240	5	200 (200:5)
220-320	240-420	0, 120-360	5	300 (300:5)
320-420	320-560	0, 160-480	5	400 (400:5)
400-520	400-700	0, 200-600	5	500 (500:5)
480-600	480-840	0, 240-720	5	600 (600:5)
540-700	560-980	0, 280-840	5	700 (700:5)
560-800	640-992	0, 320-960	5	800 (800:5)

Table 1: Wiring Configuration Based on Motor Full Load Amps

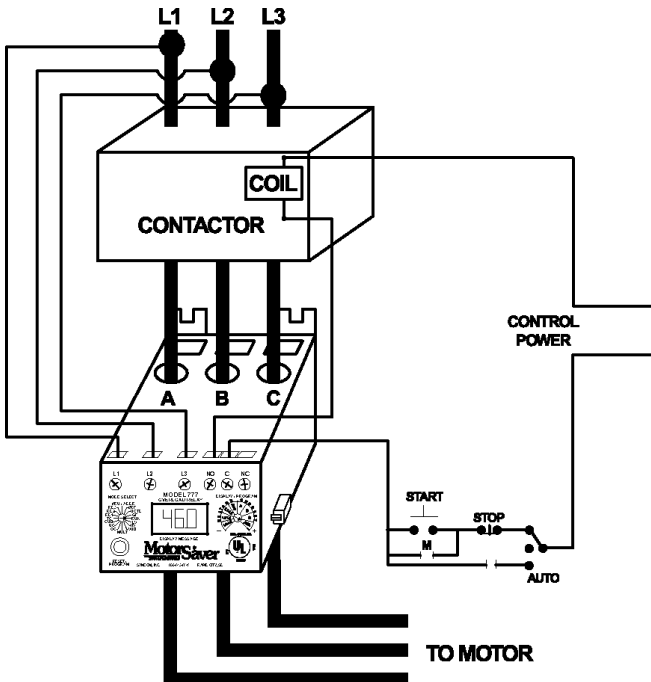
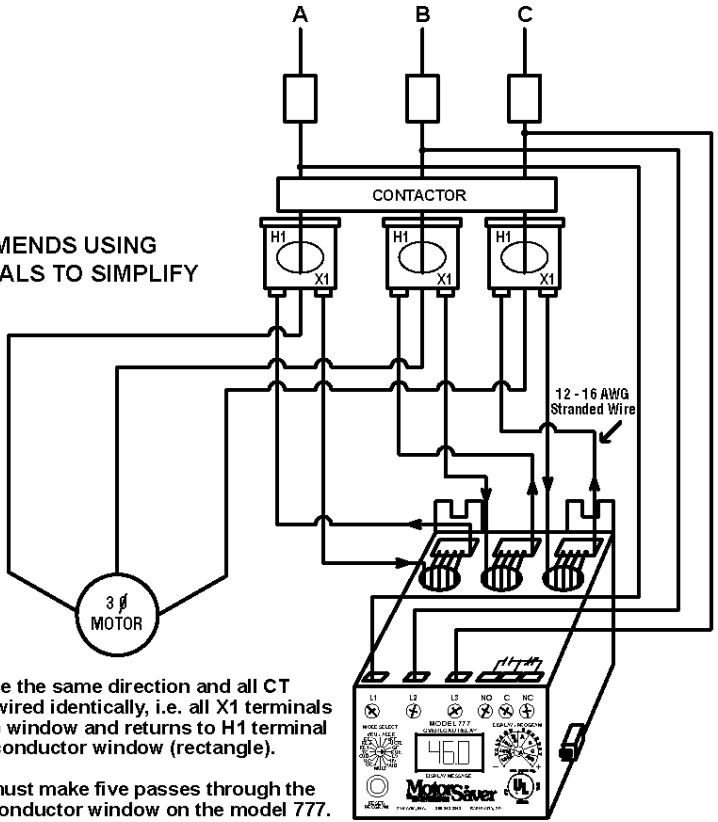

Figure 1: Typical Wiring Diagram for FLA of 26-90

SYMCOM RECOMMENDS USING CTs WITH TERMINALS TO SIMPLIFY INSTALLATION.



Note: All CTs must face the same direction and all CT secondaries must be wired identically, i.e. all X1 terminals enter the main (round) window and returns to H1 terminal after exiting the loop conductor window on the model 777.

Every CT secondary must make five passes through the corresponding main conductor window on the model 777.

Figure 2: Typical Wiring Diagram Using External CTs.

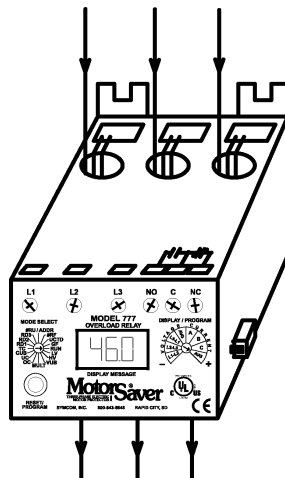

Figure 3: Looping Example Showing Three Conductors (MULT=3 from Table 1)
(No other necessary connections are shown.)

PROGRAMMABLE PARAMETERS

The following settings MUST be programmed by the user in order to provide proper protection for the application. All parameters are actual values except for the VUB and CUB settings; these are programmed as percentages. The range each parameter can be programmed to is found on the electrical specifications table on page 13. See page 8 for programming examples.

LV/HV - The recommended settings for LV (low voltage) and HV (high voltage) according to the NEMA MG1 standard are $\pm 10\%$ of the motors nameplate voltage. For other settings, the motor manufacturer should be contacted.

Example: The motor nameplate voltage is 230 volts. 90% and 110% of 230 is $0.9 \times 230 = 207$ volts for the LV setting and $230 \times 1.1 = 253$ volts for the HV setting. These parameters are based on the average voltage going to the motor.

VUB - VUB (voltage unbalance) is factory set at 6%. The NEMA MG1 standard says a motor should not be operated above a 1% voltage unbalance without derating the motor. Most utility supplied power sources have a difficult time sustaining a 1% VUB. The motor manufacturer should be consulted for an exact VUB setting. A setting of 999 for VUB will disable the VUB protection but will not disable SP (single-phase protection).

The VUB is calculated as follows:

$$\%VUB = [(Maximum\ deviation\ from\ the\ average)/Average] \times 100\%$$

Example: Measured line-line voltages = 203, 210, and 212, so the average = $(203+210+212)/3 = 208.3$, the maximum deviation from the average is the biggest difference between the average voltage (208.3) and any one voltage reading, $212 - 208.3 = 3.7$, $210 - 208.3 = 1.7$ and $208.3 - 203 = 5.3$, therefore the maximum deviation from the average is 5.3. The VUB is then = $5.3/208.3 \times 100 = 2.5\%$.

MULT - MULT (multiplier) setting is found on Table 1. The MULT setting is determined by the current the unit will be monitoring. This allows the unit to display the correct current. Changing this setting will also change the UC, OC, and GF setpoints.

OC - OC (overcurrent) is usually set at the service factor amperage (typically 100-115% of motor FLA) of the motor, which is determined by the motor manufacturer. If any one leg of current exceeds the OC setting, the unit will follow its overload trip curve (see Figure 4).

UC - UC (undercurrent) is typically set at 80% of the full-load amperage of the motor. This is usually adequate for protection of loss of load for many pumps and motors, including submersibles. If the motor is not pulling near full load amperage then the UC may have to be set to something higher than 80% of FLA for adequate protection. UC can be set to 0 if UC protection is not desired. The UC trip point examines average current to determine if an undercurrent trip condition exists.

CUB - CUB (current unbalance) is factory set to 7%. SymCom recommends the motor manufacturer be contacted for an exact setting. The CUB is calculated the same way the VUB is determined above. The CUB protection can be disabled by programming a 999 in this setting. This will disable current unbalance protection and current single phasing protection.

TC - TC (trip class) is the parameter used to determine when the unit will trip when an overload condition is detected. For standard motors, the TC is typically set at 20. The motor manufacturer should be contacted for exact TC settings. Table 2 and Figure 4 show the TC settings and trip times.

RD1 - RD1 (restart delay one) is the rapid-cycle timer in seconds. This timer is initiated when power is first applied to the unit. If voltages are within the programmed limits and no SP (single-phase) or RP (reverse-phase) condition exists when power is applied to the device, the output relay will energize (the NO will close and the NC will open) as soon as RD1 expires). Typically, this is set to 20-30 seconds. This will provide adequate protection for successive power outages or short cycling caused by other motor controls. This timer is also initiated when another control shuts the motor off (current goes to zero). If the user does not want the unit's relay to de-energize when another control shuts the motor off, then RD1 should be set to zero. This will also ensure that when an alarm circuit is used, an alarm will sound only when there is a true problem or when power is lost.

RD2 - RD2 (restart delay two) is the restart timer, in minutes, used when the unit has shut off due to a current unbalance, current single phasing, or an overload condition. This timer is known as a motor cool-down timer. A setting of 5-10 minutes will give most motors adequate time to cool down after an overload condition. The motor manufacturer should be contacted for an exact value.

RD3 - RD3 (restart delay three) is the restart timer, in minutes, used after an undercurrent trip. It is also known as a dry-well recovery timer in pumping applications. This would be the time it takes a well to recharge after pumping dry. This setting varies widely from application to application and there is no typical setting.

#RU/ADDR - The #RU/ADDR is a dual function setting. The #RU settings cover from the 7 o'clock position to the 11 o'clock position. ADDR settings start after the 11 o'clock position.

#RU is the number of restarts after an undercurrent trip condition before the unit locks and requires a manual restart. This counter will be cleared one minute after start-up if the unit does not trip again on UC. #RU can be set to 0, 1, 2, 3, 4, or A. A setting of zero means no automatic restarts after an undercurrent. A setting of "A" means the unit will always automatically restart after an undercurrent.

ADDR is the RS-485 address of the particular device. This is only used when communicating with an RM-2000 (set ADDR=A01), a PLC, or PC. The ADDR can be programmed from A01-A99.

#RF - #RF is the number of restarts allowed after a current unbalance, current single phasing, or an overload condition. A setting, which includes an "oc" prefix, will include overcurrent in the number of successive restarts. If "oc" is not a prefix to the programmed setting, the unit will require a manual restart after an overcurrent. A setting of zero means the unit will not try to restart after a CUB, OC, or SP. A setting of "ocA" means the unit will always try to restart after a CUB, OC, or SP.

UCTD - UCTD (undercurrent trip delay) is the amount of time, in seconds, the unit will allow the motor to run in an undercurrent situation before de-energizing its relay. Typically, UCTD is set to 2-4 seconds.

GF - GF (ground fault) is the maximum allowable current, which can flow to ground before the unit de-energizes its relay. This is a residual, class II ground fault system and should not be used for personnel safety. A typical setting for this is 10%-20% of the motor full load current. The real GF current level is programmed into the unit. The GF test procedure on the last page of the installation instructions must be conducted before the device is brought online.

PROGRAMMING

1. Rotate the MODE SELECT switch to the parameter to be programmed. SymCom recommends that LV be programmed first and then move clockwise through the positions to complete the process.
2. Press and hold the RESET/PROGRAM button.
3. Rotate the DISPLAY/PROGRAM knob until the proper setting for the parameter that is being programmed is displayed.
4. Release the RESET/PROGRAM button. This stores the new parameter in the nonvolatile memory. If the number changes back to what it was before programming, then the tamper guard is on and will need to be unlocked before programming can be completed. (See page 14 for tamper guard procedures.)
5. Continue steps 1-4 until all parameters are programmed.

OPERATION

The relay operation of the Model 777 is designed to be fail safe. This means when everything is within the limits programmed into the unit, the relay will energize, the NO contact will close and the NC contact will open. Once the unit has been wired and programmed, the unit is ready to operate. Turn MODE SELECT to the RUN position. The display will show "run" alternating with some number (the numbers displayed will be the number corresponding to where the DISPLAY/PROGRAM knob is pointed). It will do this for the amount of time programmed into RD1. After this time has expired, the relay will energize (NO contact will close and the NC contact will open). If something else is in the display, see the troubleshooting section for more information. If the MODE SELECT is taken out of the RUN position, the units relay will de-energize.

Trip Class	Application Description
5	Small fractional horsepower motors where acceleration times are almost instantaneous or where extremely quick trip times are required
10	(Fast Trip) Hermetic refrigerant motors, compressors, submersible pumps and general-purpose motors that reach rated speed in less than 4 seconds.
15	Specialized applications.
20	(Standard Trip) Most NEMA-rated general-purpose motors will be protected by this setting.
30	(Slow Trip) Motors with long acceleration times (>10 seconds) or high inertia loads.
J Prefix	Programming any of the trip classes with the J prefix will enable jam protection. This additional protection is enabled 1 minute after the motor starts and provides a 2 second trip time for motors exceeding 400% of the OC setting, regardless of trip class.

Table 2: Trip Class Descriptions

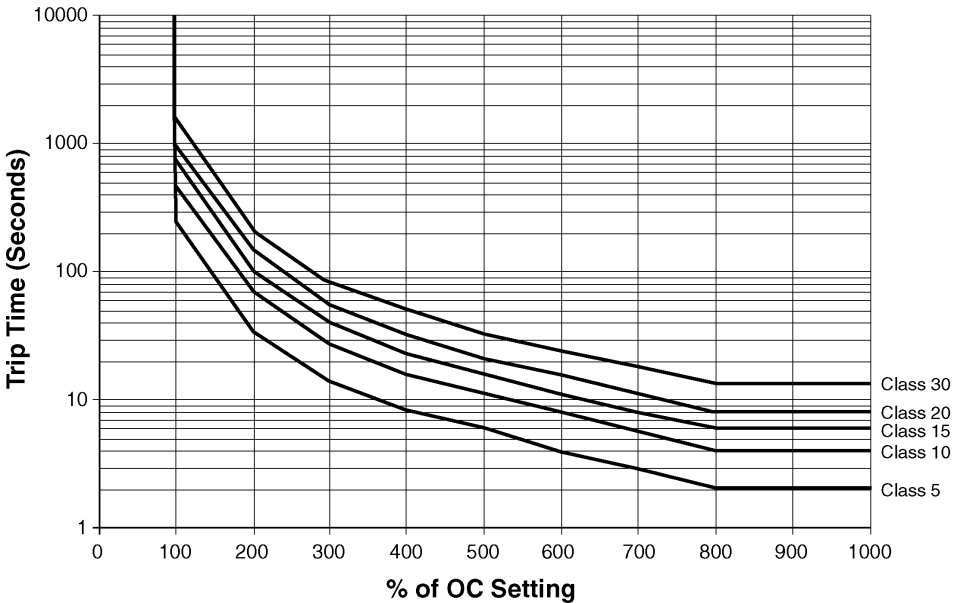

Figure 4: Overload Trip Curves

PROGRAMMING EXAMPLES

Example #1

Motor to be protected: 3-phase, 460 Volt, 25 hp air compressor with a full load amperage rating of 34A and maximum service factor amps of 37.4. Use the following calculations and reasoning to determine the appropriate settings for this application.

LV-	$460 \times 0.90 = 414$
HV-	$460 \times 1.10 = 506$
VUB-	Standard NEMA motor = 5
MULT-	From Table 1 = 1
OC-	Service Factor Amperage = 37.4
UC-	$FLA \times 0.80 = 34A \times 0.80 = 27.2$
CUB-	Standard NEMA motor = 5
TC-	General purpose motor = 20
RD1-	Since this compressor takes about 10 seconds to bleed off excess pressure after a shutdown, setting RD1 = 20 will allow the compressor to unload before being restarted.
RD2-	Because the motor may be hot from running in an unbalance or single phase condition, a motor cool-down time of 10 minutes, RD2 = 10, should be appropriate.
RD3/#RU-	Because an undercurrent would signal a serious problem in this application (a broken shaft or belt), #RU should be set to 0 for a manual reset. Therefore, RD3 does not have any function
#RF-	Because an overload (overcurrent) fault signals a serious problem in this application (e.g., worn bearings), "oc" should not be included in the #RF setting so that a manual reset after an overload fault is required. A #RF=1 will give the system 1 chance to recover from an unbalance or single phasing problem before manual reset is required.
UCTD-	Setting UCTD = 5 will allow normal operation and not allow the motor to run too long in a failure mode.
GF-	A ground fault setting of 15% of full load amps will be a significant indicator that the motor should be evaluated for repair or replacement. Therefore, GF = $34A \times 0.15 = 5.1$.

Example #2

Motor to be protected: 3-phase, 230 Volt, 5 hp submersible pump with a full load amperage of 15.9 A and maximum service factor amps of 18.2. Use the following calculations and reasoning to determine the appropriate settings for this application.

LV-	$230 \times 0.90 = 207$
HV-	$230 \times 1.10 = 253$
VUB-	Manufacturer suggests 5
MULT-	From Table 1, MULT = 2, 1 loop of main conductor
OC-	Service Factor Amperage = 18.2
UC-	$FLA \times 0.80 = 15.9 \times 0.80 = 12.7$
CUB-	Manufacturer suggests 5
TC-	From Figure 3, for this (and most) submersible pumps, TC = 10 (fast trip)
RD1-	To protect the pump from rapid cycling, RD1 = 60

- RD2- Since the motor is small and submerged in water, the motor will generally cool down quickly. RD2=5
- RD3- The well history shows that it will fully recover in 2 hours. RD3 = 120
- #RU- In this application, we know that the well will eventually recharge itself, #RU = A (Automatic).
- #RF- This well is known for sand to jam the impeller, therefore "oc" should be included so that the pump will attempt to automatically restart after an overloaded condition. History shows that 2 or 3 starts and stops usually clears the sand out of the impeller. #RF= oc2 or oc3.
- UCTD- This well may become air locked on startup, but will usually re-prime itself in 5 seconds or less. UCTD = 10
- GF- Because this type of fault indicates the impending failure of the motor and it may take several days to get a new pump and schedule for a driller to remove and replace the pump, GF setting of 10% of full load amperage will give the well owner enough time to prepare for pump replacement. $GF = 15.9A \times 0.10 = 1.59$

SYSTEM DISPLAY

The output display can show one of the following parameters when the MODE SELECT switch is in the RUN position: average voltage or current, each line current, or each individual line-line voltage. The display is also used for programming the operating parameters of the device. The display also identifies what caused the unit to de-energize its relay or what is keeping the unit from energizing its relay. The last fault (not the current fault) can be displayed by pressing and holding the RESET/PROGRAM button while the MODE SELECT switch is in the RUN position. When the unit trips off or is holding the motor off, the current fault condition will be shown in the display without pressing the button. Table 3 below lists the fault codes the unit could display.

Displayed Message	Meaning
oc	Tripped on overcurrent
SP	Tripped on current single phasing or unit won't start because the voltage is single phased
ub	Tripped on current unbalance or unit won't start because the voltage is unbalanced
uc	Tripped on undercurrent
CF	Tripped on contactor failure
GrF	Tripped on ground fault
H I	A high voltage condition exists
Lo	A low voltage condition exists
rP	Incoming phases have been reversed, the motor may run backwards if started
oFF	A stop command was issued from a remote source

Table 3: Fault Codes and Their Meaning

COMMUNICATIONS PORT/REMOTE RESET

The unit comes with a 9-pin sub-D connector for remote communications and/or for using a remotely located reset button. If communications are desired, a communication module (part number RS485MS-2W) needs to be plugged into this 9-pin connector (this is mandatory when communicating with the unit). This module provides isolation, signal conditioning for compatibility with Modbus RTU and RS-485 networks, and provides terminals for terminating the shielded communications cable. Up to 99 units can be installed on one RS-485 network.

Further information can be obtained at <http://www.symcominc.com> or by calling in a request. A remote reset button can be hooked up to the communications module (pn RS485MS-2W) or can be hooked directly to the 9-pin connector using a male sub-D connector. It should be wired as shown in Figure 5.

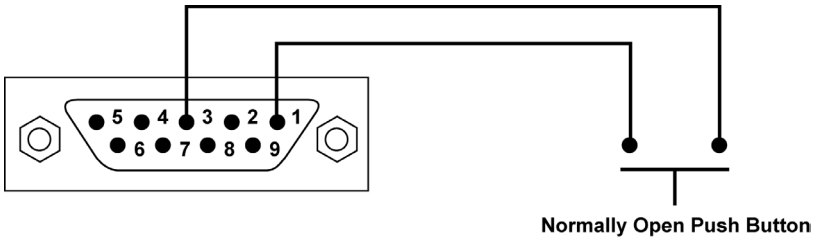

Figure 5: Remote Reset Button Wiring Diagram

TROUBLESHOOTING

The MotorSaver® will display a fault code alternating with a number or with “run” when it is in a trip condition. If the unit is showing a fault code (see Table 4) alternating with “run,” it has tripped on a current (amperage) condition. If the fault code is alternating with some number (voltage reading or zero), the unit will not allow the motor to start because there is a problem with the incoming voltage. If the display is showing just a fault code, the unit is in a mode that requires a manual reset. This could be because the number of restarts (#RF, #RU) has expired or is not allowed. If the display reads “off,” a stop command was issued through the communications network.

PROBLEM	SOLUTION
The unit will not start. Display alternates “rP” with the DISPLAY/PROGRAM parameter value.	The voltage inputs are reverse phased. If this is the initial start-up, swap any two of the leads connected to L1, L2, or L3 on the 777 to correct the problem. If the overload relay has been previously running, the power system has been reverse phased. Check the phase sequence of the incoming power lines. Note: L1 must be tapped from conductor Phase A, L2 from B, and L3 from C for correct power factor measurements on remote communications.
The unit will not start. Display alternates “SP”, “ub”, “HI”, or “Lo” with the DISPLAY/PROGRAM parameter value.	The incoming voltage is not within the limits programmed in the VUB, HV, and LV settings. Adjust the DISPLAY / PROGRAM switch to read the incoming line voltage values. Correct the incoming power problem and check programmed limits to verify they are correct.
Display alternates “SP”, “ub”, or “oc” with “run.”	The overload relay has tripped on the fault shown on the LED display and is timing down RD2 before restarting.
Display alternates “uc” with “run.”	The overload relay has tripped on undercurrent and is timing down RD3 before restarting. If undercurrent is not a normal condition for this installation, check for broken shafts, broken belts, etc.
Display is showing a solid “SP”, “ub”, or “oc.”	The unit has tripped on the fault shown and a manual reset is required because of the programmed setting in #RF. Check the system for problems that would produce the single-phase, overload or current unbalance fault, such as a jam.
Display is showing a solid “uc.”	The unit has tripped on undercurrent and a manual reset is required because of the setting in #RU. Check the system for problems that would produce a loss of load such as a broken belt or a lack of liquid to pump.
Display is showing a solid “CF.”	The unit has tripped on current single phasing, but was not single phased by the incoming voltage. Check for damaged contacts or loose wiring.
Display is showing a solid “GrF.”	A ground fault current greater than the programmed GF value has been detected. A manual reset is required. Check the motor for insulation breakdown.

Table 4. Troubleshooting

MODEL 777 SPECIFICATIONS

Electrical	
Input Voltage	200-480VAC, 3-phase (Standard) 500-600VAC for Model 777-575
Frequency	50-60 Hz
Motor Full Load Amp Range	2-25A, 3-phase (Looped conductors required) 25-90A, 3-phase (Direct) 80-800A, 3-phase (External CTs)
Power Consumption	10W (Maximum)
Output Contact Rating SPDT (Form C)	Pilot duty rating: 480VA @ 240VAC General purpose: 10A @ 240VAC
Expected Life	
Mechanical	1 x 10 ⁶ operations
Electrical	1 x 10 ⁵ operations at rated load
Accuracy at 25° C (77° F)	
Voltage	±1%
Current	±3%(<100A Direct)
GF Current	±15%
Timing	5% ±1 second
Repeatability	
Voltage	±0.5% of nominal voltage
Current	±1% (<100A direct)
Trip Times (Those not shown have user selectable trip times.)	
<u>Ground Fault Trip Time</u> 101%-200% of Setpoint 201%-300% of Setpoint 301%-400% of Setpoint 401% or Greater	<u>Trip time</u> 8 seconds ±1 second 4 seconds ±1 second 3 seconds ±1 second 2 seconds ±1 second
Current Unbalance Trip Times <u>% Over Setpoint</u> 1% 2% 3% 4% 5% 6% 10% 15%	<u>Trip time</u> 30 seconds 15 seconds 10 seconds 7.5 seconds 6 seconds 5 seconds 3 seconds 2 seconds
Safety Marks	
UL	UL508, UL1053
CE	IEC 60947-1, IEC 60947-5-1
Standards Passed	
Electrostatic Discharge (ESD) Radio Frequency Immunity (RFI), Conducted Radio Frequency Immunity (RFI), Radiated	IEC 1000-4-2, Level 3, 6kV contact, 8kV air IEC 1000-4-6, Level 3 10V/m IEC 1000-4-3, Level 3 10V/m
Fast Transient Burst	IEC 1000-4-4, Level 3, 3.5 kV input power
Surge	
IEC	1000-4-5 Level 3, 2kV line-to-line; Level 4, 4kV line-to-ground

ANSI/IEEE	C62.41 Surge and Ring Wave Compliance to a level of 6kV line-to-line
Hi-potential Test	Meets UL508 (2 x rated V +1000V for 1 minute)
Vibration	IEC 68-2-6, 10-55Hz, 1mm peak-to-peak, 2 hours, 3 axis
Shock	IEC 68-2-27, 30g, 3 axis, 11ms duration, half-sine pulse
Mechanical	
Dimensions	3.0"H x 5.1 " D x 3.6"W
Terminal Torque	7 in. lbs.
Enclosure Material	Polycarbonate
Weight	1.2 lbs
Maximum Conductor Size Through 777	0.65" with insulation
Environmental	
Temperature Range	Ambient Operating: -20°-70° C (-4°-158°F) Ambient Storage: -40°-80° C (-40°-176°F)
Pollution Degree	3
Class of Protection	IP20, NEMA 1
Relative Humidity	10-95%, non-condensing per IEC 68-2-3
Programmable Operating Points	Range
LV- Low Voltage Threshold	170V (450V*) - HV Setting
HV- High Voltage Threshold	LV Setting - 528V (660V*)
UB- Voltage Unbalance Threshold	2-15% or 999%
MULT- # of Conductors or CT Ratio (XXX:5)	1-10 Conductors or 100-800 Ratio
OC- Overcurrent Threshold	(20-100A) ÷ MULT or 80-120% of CT Primary
UC- Undercurrent Threshold	(0, 10-98A) ÷ MULT or 40-100% of CT Primary
CUB- Current Unbalance Threshold	2-25% or 999%
TC- Overcurrent Trip Class **	5, J5, 10, J10, 15, J15, 20, J20, 30, J30
RD1- Rapid Cycle Timer	0, 2-500 Seconds
RD2- Restart Delay After All Faults Except Undercurrent (motor cool-down timer)	2-500 Minutes
RD3- Restart Delay After Undercurrent (dry-well recovery timer)	2-500 Minutes
#RU- Number of Restarts After Undercurrent	0, 1, 2, 3, 4, A (Automatic)
ADDR- RS485 Address	A01- A99
#RF-Number of Restarts After All Faults Except Undercurrent	*** 0, 1, oc1, 2, oc2, 3, oc3, 4, oc4, A, ocA
UCTD- Undercurrent Trip Delay	2-60 Seconds
GF- Ground Fault Current Threshold	(3-20A) ÷ MULT or 10-30% of CT Primary or OFF

NOTES: SymCom's Overload Relay can be preprogrammed prior to installation by applying 120VAC between the L1 and L2 terminals (except 575 Volt model). Power applied must be 110VAC or greater.

* 575 Volt model.

** If J Prefix is displayed in trip class setting, jam protection is enabled.

*** If "oc" is displayed in the #RF setting, then overcurrent will be included as a normal fault and the relay will automatically restart after RD2 expires, otherwise, manual reset is required after an overcurrent fault.

CLEARING LAST FAULT

The last fault stored can be cleared on the MotorSaver® by following these steps:

1. Rotate the MODE SELECT switch to GF.
2. Press and hold the RESET/PROGRAM button. Adjust the DISPLAY/PROGRAM adjustment until “cLr” appears on the display. Release the RESET/PROGRAM button.

To verify the last fault was cleared, place the MODE SELECT switch in the RUN position. Then press and hold the RESET/PROGRAM button; “cLr” should be on the display.

TAMPER GUARD

The MotorSaver's setpoints can be locked to protect against unauthorized program changes.

1. Rotate the MODE SELECT switch to GF.
2. Press and hold the RESET button. Adjust the DISPLAY/PROGRAM knob until “Loc” appears on the display.
3. Release the RESET button.
4. Turn MODE SELECT switch to RUN.

The program is now locked, but all settings can be viewed. The unit can be unlocked by following the same steps except adjust the DISPLAY/PROGRAM knob to “unL” in step 2.

GROUND FAULT TESTING PROCEDURE

A ground fault test must be performed before installing the MotorSaver® as required by UL1053 and NEC, ANSI/NFPA 70.

1. Disconnect power.
2. Hook up the three line voltages to L1, L2, and L3 as required by the installation instructions.
3. Program the desired parameters into the unit. For test purposes, set MULT to 1 and GF to the minimum allowed setting.
4. Construct the circuit, using an AC power supply. This circuit simulates a ground fault condition by generating a current in one of the phases. Alternate test circuits may be used. The only requirement is the current through the current transformer must be between 115% and 150% of the GF setting and pass through only one CT window.

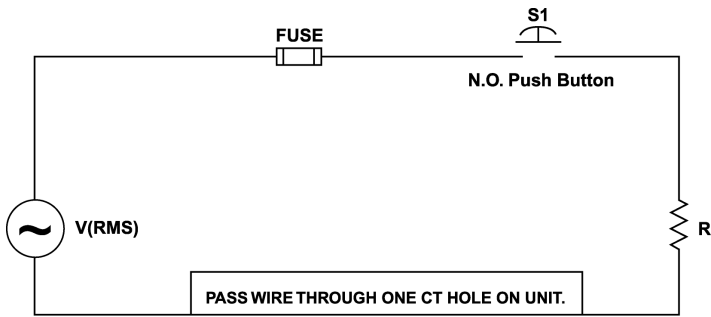

5. The values of V and R will be determined by the current required to generate a GF trip condition: $I = V_{rms}/R$, where $I = 115\%$ of GF setting.
6. Place the unit in the RUN position, apply 3-phase power and allow the NO contact to close.
7. Energize the test circuit by pushing and holding the test pushbutton until the unit trips (within 8.5 seconds). The display should show "GrF" and the NO contacts should be open. Release the NO pushbutton.
8. The results of the test are to be recorded on the test form provided below. The form should be kept by those in charge of the building's electrical installation in order to be available to the authority having jurisdiction.
9. Confirm programmed parameters and proceed with installation instructions.

GROUND FAULT TEST RESULTS*

<u>Date</u>	<u>Performed by</u>	<u>Results</u>	<u>Location</u>
-------------	---------------------	----------------	-----------------

*A copy of this form should be retained by the building's electrical foreman.

SymCom Warrants its microcontroller based products against defects in material or workmanship for a period of five (5) years from the date of manufacture. All other products manufactured by SymCom shall be warranted against defects in material and workmanship for a period of two (2) years from the date of Manufacture. For complete information on warranty, liability, terms, returns, and cancellations, please refer to the SymCom Terms and Conditions of Sale document.

Visit our website at www.symcominc.com
for our complete catalog and new product listings!



2880 North Plaza Drive
Rapid City, SD 57702 · (800) 843-8848