

TIMERS FOR HVAC SYSTEMS

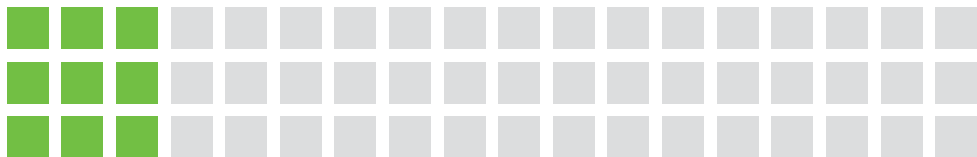

TECHNICAL PAPER



Expertise Applied | Answers Delivered

Overview

Time-delay relays protect HVAC equipment from damage caused by rapid cycling of compressors. Our experts have created this application guide to assist technical engineers in their efforts to improve product lifespan and reduce maintenance of equipment.

Debouncing – Demand Reduction Timers

Random Start Sequencing

Random start sequencing is a common practice used to prevent overloading of power lines due to peak demand current levels. Peak demand usually occurs after power failures or when night shutdown systems are used.

A low-cost random start system includes a delay-on-make time delay in the control circuitry of the system as shown in **Figure 1**. Random start timers are placed in each piece of equipment, each timer set for a different time delay period.

The random start delay is connected so that its time delay occurs after loss of power. When power is restored, the normally open solid-state output of the TDU#1 timer keeps the transformer de-energized for a selected time delay. Upon completion of this delay, the solid-state output changes state and the transformer is energized.

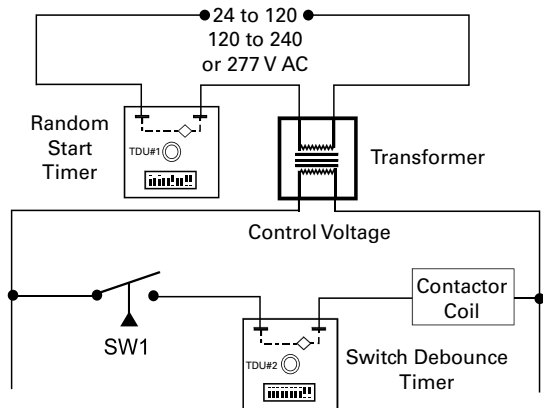

FIGURE 1. Random Start Sequencing

Preventing Contact Chatter

Switch bounce can cause unacceptable contact chatter. In this application, the TDU#2 timer is used to debounce control switch SW1. Upon closure of SW1, the normally open solid-state output of the TDU#2 timer keeps the contactor coil de-energized during the debounce time delay. Upon completion of the time delay, the contactor is energized. The debounce time delay will be reset to zero if SW1 opens at any time prior to the completion of the TDU#2 time delay.

Exhaust Fan Delay

In many existing installations, a neutral connection (white wire) is not available in the switch box. The two terminal delay-on-break THD1 is perfect for these installations. SW1, when closed, operates the fan directly and holds THD7 reset (see **Figure 2**). When SW1 opens, THD7 times and holds the fan on until the end of the time delay. The system is reset each time SW1 is closed (see **Figure 3**).

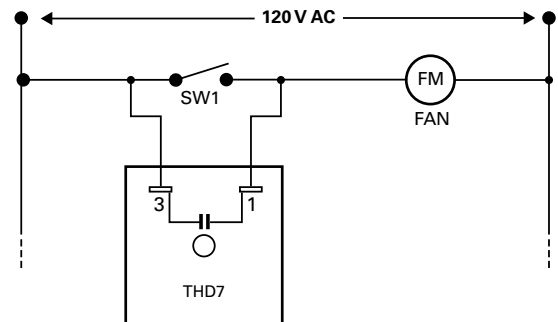

FIGURE 2. Wiring Diagram for Exhaust Fan Delay

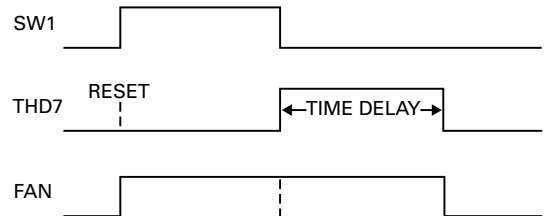

FIGURE 3. Timing Diagram for Exhaust Fan Delay

Prepurge Gas Vapors

When the thermostat closes, the fan turns on. While purging the combustion chamber, the fan forces the flag switch to close, applying power to the solid-state timer as shown in **Figure 4**. The time delay starts, keeping ignition controls off until gas vapors are removed. The solid-state timer then sends power to the flame sensor control section, which fires the electrode.

If the pilot is lit, the main burner is also lit. If the flame sensor does not see a flame, as shown in **Figure 5**, the electrode is fired one more time. After a second failure, the system goes into lockout and must be manually reset (lockout circuitry not shown).

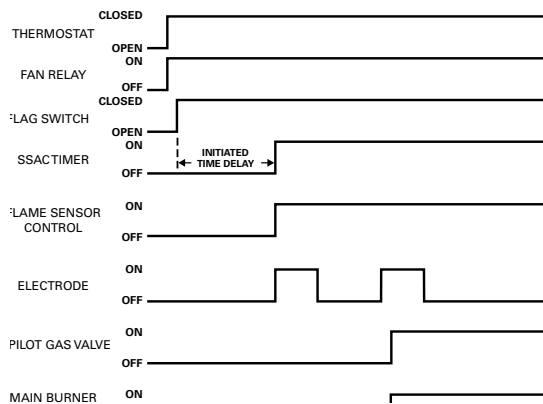

FIGURE 4. Wiring Diagram for Prepurge Gas Vapors System

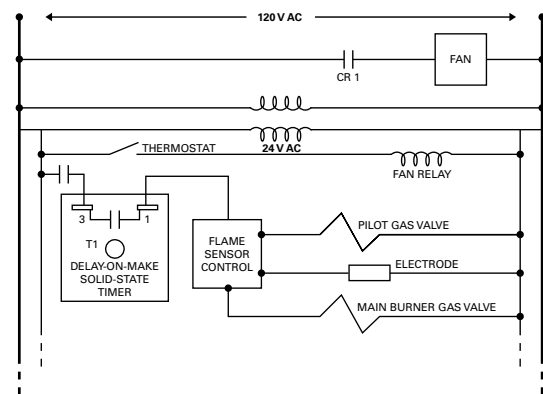

FIGURE 5. Timing Diagram for Prepurge Gas Vapors System

A Dual Anti-Short Cycle Timer – Lockout Plus Random Start Delay

Unfortunately, momentary power outages can oftentimes cause motors to short cycle. The utilities reclosing process attempts to reestablish power automatically after a fault has tripped OFF a supply line. The reclosing breaker makes three attempts to reestablish power. Each attempt is a few seconds after the circuit re-trips.

Compressors, pumps, machine tools and milling machines that operate with variable loads may not be able to start under peak loading. These motors may be subjected to excessive locked rotor stress after a momentary power outage.

The compact T2D series time-delay relay doubles the protection provided by traditional anti-short cycle timers. When power is applied, a random start delay begins. The T2D's solid state output is OFF during the random start delay. After timeout, the output energizes and latches ON regardless of the condition of the initiate switch.

With traditional random start timers, the time delay doesn't begin (see **Figure 6**) until the initiate switch is closed. When the initiate switch opens ending the machine cycle, another anti-short cycle delay called a lockout delay begins. The machine cannot be restarted until this delay is completed. This relay limits the number of motor starts per hour.

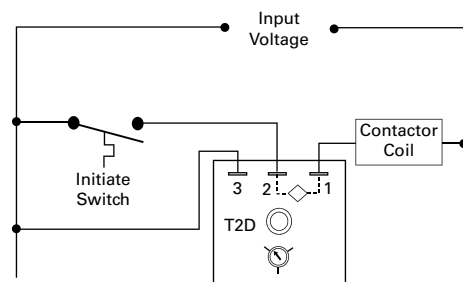

FIGURE 6. Lockout Plus Random Start Delay

Conclusion

Using the right timer for an HVAC application is a cost-effective way to help ensure that a system is running reliably and efficiently. Additional specifications and applications information for the complete line of timers from Littelfuse can be found at Littelfuse.com/Timers to help you choose the right series. Or, you can call +1 800-832-3873 or email relays@littelfuse.com for technical support.



For more information, visit
Littelfuse.com/Timers

