

Automotive Sensor Products

DEF Level Sensing – PWG™

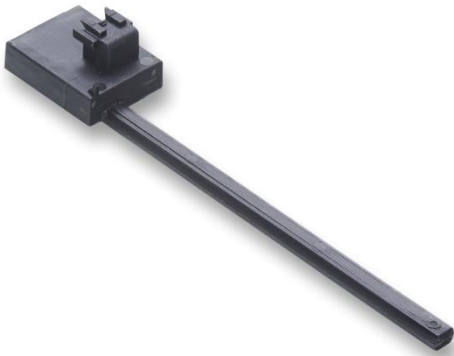

General Description

Littelfuse *Pulsed WaveGuide™* (PWG™) sensor technology, patent pending¹, is a cost effective linear position sensing technology that is capable of producing a highly versatile, robust and accurate distance measurement solution.

The Pulsed WaveGuide Sensor package contains signal conditioning electronics and a screened wave guide transmission line – the sensing element. When used in conjunction with a suitable permanent magnet, the signal transmitted along the wave guide is reflected at the magnet position. The time of flight between start of transmission and the reflected signal is directly proportional to the distance between the start point of the wave guide and the magnet position.

In order to minimize power consumption, the measurement frequency can be optimized. In addition, the measurement mode can also be set to burst mode and poll mode. In burst mode the system enters a sleep state and awakes to report position at preset intervals; in poll mode the sensor reports position upon demand from an ECU.

Features

- ◆ Contactless linear position sensor
- ◆ Robust, simple, cost effective design
- ◆ Works with Ferrite magnet 4mT (40Gauss)
- ◆ Sensor stroke lengths up to 340mm
- ◆ Longer designs feasible upon request
- ◆ Accuracy without correction < 2%
- ◆ Low current consumption < 20mA
- ◆ Operating temperature range: -40°C up to +145°C

Applications

- ◆ Linear Actuator Position Sensing
- ◆ Liquid Level Sensing, SCR
- ◆ Valve Position Sensing
- ◆ Clutch and Brake cylinder piston position
- ◆ Vehicle suspension height sensing
- ◆ Robotic Applications
- ◆ Industrial Positioning Applications

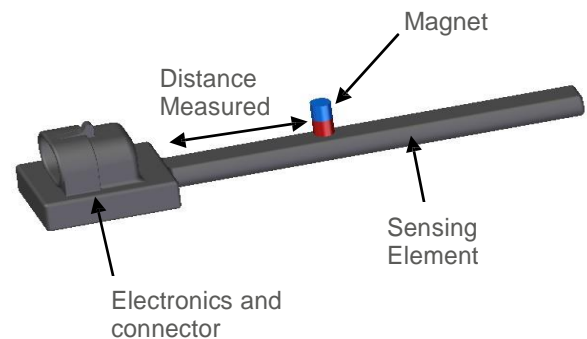

Figure 1: Typical PWG sensor and magnet arrangement

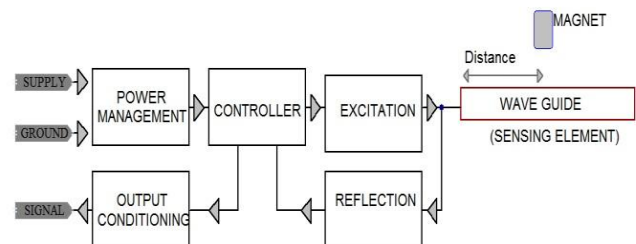

Figure 2: System Block Diagram

¹ European patent application 12006827.5; US Provisional patent application no. 61/810802; Other patent applications pending.

Automotive Sensor Products

Table of Contents

General Description.....	1
Features	1
Applications	1
Version History	2
Technical Specifications	3
Absolute Maximum Ratings.....	4
EMC Specifications	4
Typical Performance Characteristics.....	5
Digital Signal Processing and Linearization	5
Magnet Selection.....	5
Typical Pin Configuration.....	5
Typical Applications.....	6

Automotive Sensor Products

Technical Specifications

Parameter	Comments	Min.	Typ.	Max.	Unit
Power Requirements					
Supply Voltage		3.3 ²	-	24	V
Supply Current	in continuous power mode ³		20		mA
Output Signal					
Ratio-metric Output Voltage		0.2*Vcc		0.8*Vcc	V
PWM Interface		10		90	%
Magnetic Requirement					
Min Field Strength Required		20 (200)			mT (Gaus
Performance					
Air Gap (AG) ⁴		0	5	10	mm
Independent Linearity ⁵			1	2	%
Resolution				12	bit
Max Measurement Length				340 ⁶	mm
Insulation Resistance		>10M			Ω
Degrees of Protection (IP-Code)	IP6K4K acc. ISO 20653 / DIN 40050-9				
Environmental Testing	Prequalified acc. IEC 60068-2 ⁷				

Table 1: Sensor Specification

² Application specific³ Low-power mode can be designed as per customer requirements⁴ Air gap (AG) varies greatly depending on magnet shape, strength and total stroke length. Littelfuse engineering team will work closely with customers to optimize performance for the application.⁵ Linearity performance stated here is raw sensor response. Further piecewise linearization with a build in microcontroller improves this performance.⁶ Longer designs feasible upon request

Automotive Sensor Products

Absolute Maximum Ratings

Parameter	Rating	Unit
Supply to GND	28	V
Operating Temperature Range	-40°C to +125 (Extended version: +145)	°C
Storage Temperature Range	-40°C to +150	°C

Table 2: Absolute Maximum Rating

EMC Specifications

Parameter	Rating/Level	standard
EMC		
Radiated Emissions, Absorber Lined Shielded Enclosure (ALSE)	Class 3	IEC CISPR 25
Conducted Emissions (CE)	Class 3	IEC CISPR 25
Radiated Immunity, Bulk Current Injection (BCI)	Level 4	ISO 11452-4
Radiated Immunity, Anechoic Chamber	100 V/m	ISO 11452-2
Conducted Immunity, Supply line	12V, Level 4 24V, Level 4	ISO 7637-2 ISO 7637-2
Conducted Immunity, Coupling to I/O	12V, Level 4 24V, Level 4	ISO 7637-3 ISO 7637-3
Immunity to Magnetic Fields	Level 4	ISO 11452-8
Electrostatic Discharge (ESD), Handling of Devices	±8kV contact ±15kV air	ISO 10605:2001

Table 3: PWG Sensor EMC Specifications

Automotive Sensor Products

Typical Performance Characteristics

Typical linearity performance of the PWG Sensor without additional signal processing or linearization is shown below in Figure 3.

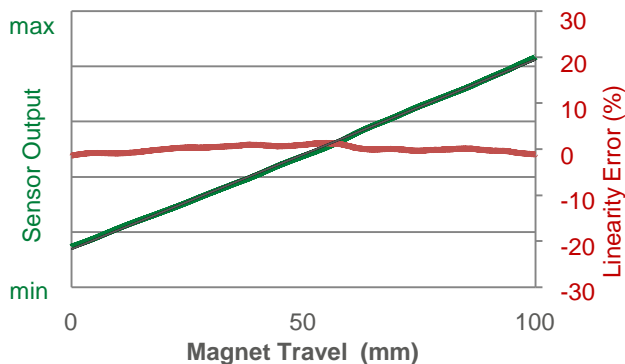

Figure 3: PWG output over 100mm of magnet travel

In this example, a ferrite ring magnet, Grade 8/22, is used at an air gap of 4mm. The linearity error of less than 2% is achieved without correction routine. Then on-board microcontroller can perform linearity correction to achieve linearity error of less than 1%.

Digital Signal Processing and Linearization

Piecewise linearization of the sensor output can also be implemented for high precision applications. Additionally, the on-board microcontroller will enable the user to customize the sensing range and report a scaled output for the set range. This programming can be applied at the sensor factory or after the sensor has been assembled in the target application.

Magnet Selection

The PWG Sensor is activated with magnetic field intensities of approximately 4mT (40 Gauss). Various magnet geometries such as ring or bar magnets can be used as shown in Figure 4 Typical PWG sensor and magnet arrangements on page 6.

Depending on the application and the proposed magnetic circuit, ferrite or rare earth magnets can be used. The selection of the magnet geometry and corresponding material properties depends on the parameters of the application, such as the air-gap, total space available, the surrounding ferromagnetic materials, and operating temperature.

Littelfuse will provide technical support utilizing magnetic modeling to define optimum solution for a given application.

Typical Pin Configuration

Connector: Customer specific;

Pin No.	Name	Description
1	SUPPLY	Supply connection
2	SIGNAL	Sensor voltage / Digital PWM
3	GROUND	Ground connection

Table 4: Pin function and description

Automotive Sensor Products

Typical Applications

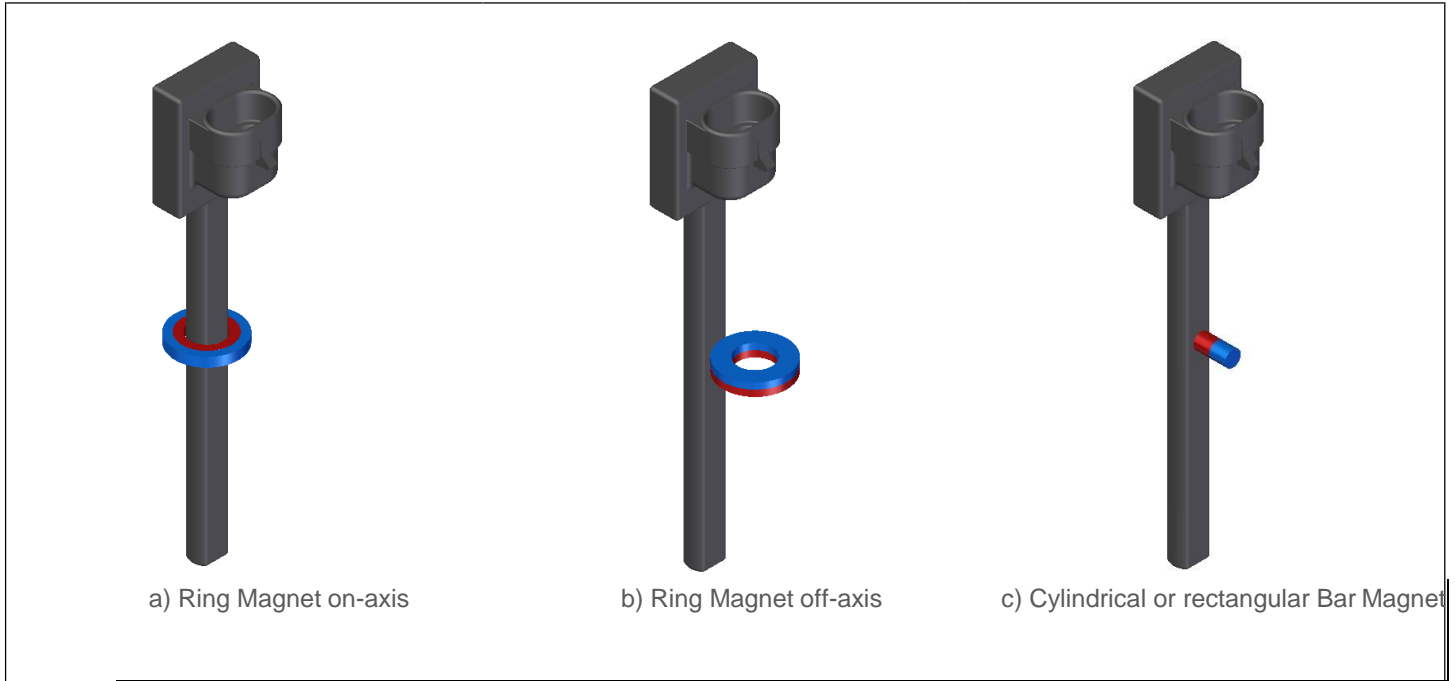

Figure 4: Typical PWG sensor and magnet arrangements

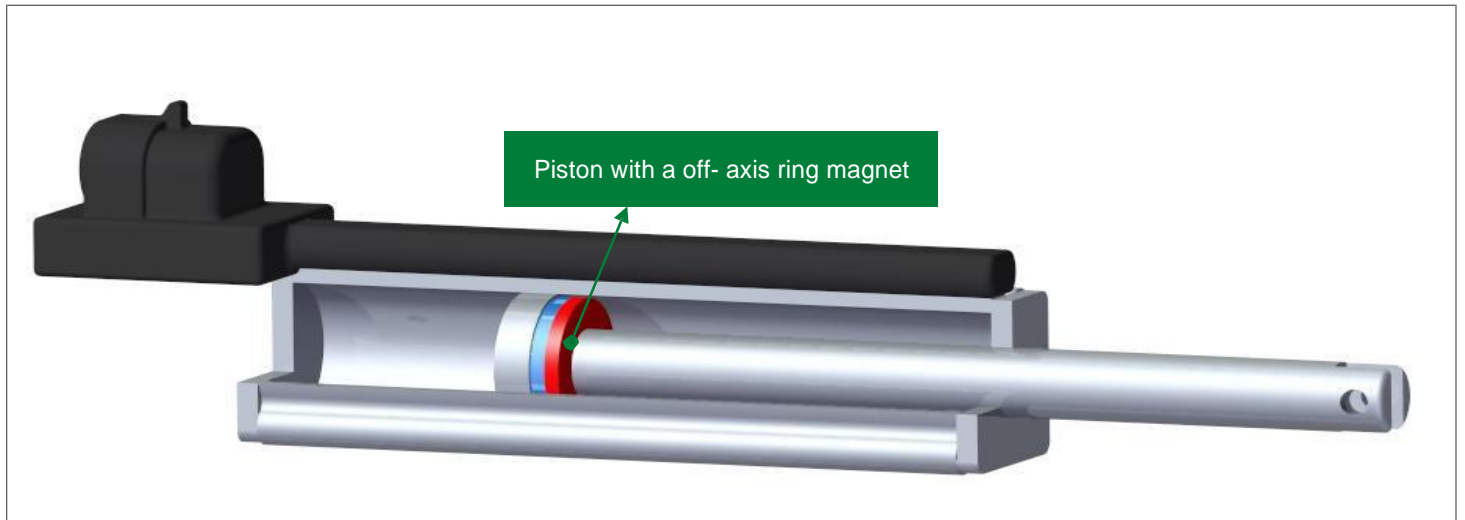

Figure 5: Piston position measurement using PWG sensor

Automotive Sensor Products

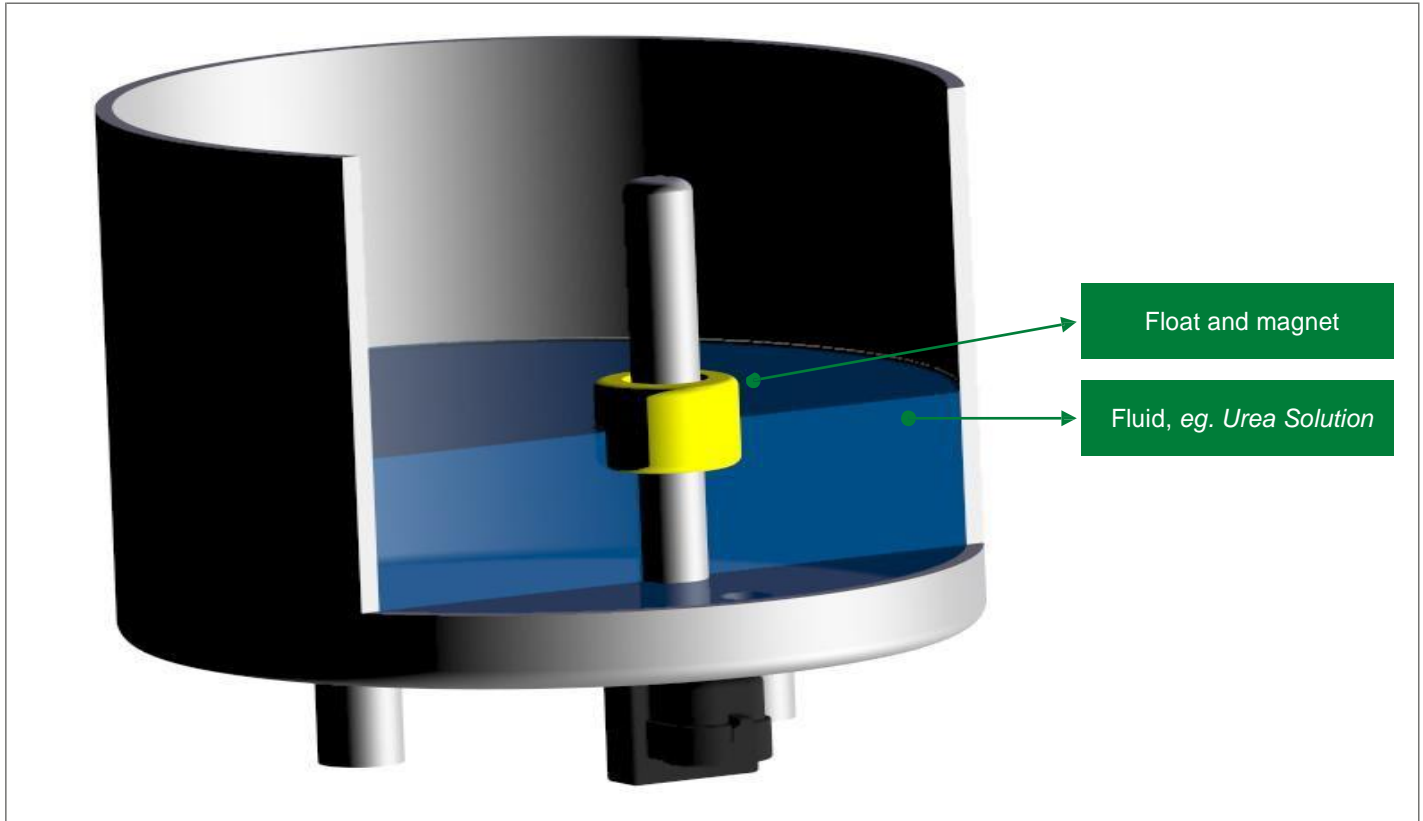

Figure 6: Fluid level measurement using PWG sensor



Figure 7: Fork Position measurement using PWG sensor

Automotive Sensor Products

Littelfuse

Website: www.littelfuse.com
Sales Support: ALL_Autosensors_Sales@littelfuse.com
Technical Support: ALL_Autosensors_Tech@littelfuse.com

Information provided by Littelfuse is believed to be accurate and reliable.

All rights reserved. Trademarks and registered trademarks are the property of their respective owners.

Littelfuse products are designed for specific applications and should not be used for any purpose (including, without limitation, automotive applications) not expressly set forth in applicable Littelfuse product documentation. Warranties granted by Littelfuse shall be deemed void for products used for any purpose not expressly set forth in applicable Littelfuse product documentation. Littelfuse shall not be liable for any claims or damages arising out of products used in applications not expressly intended by Littelfuse as set forth in applicable Littelfuse product documentation.

Patents applications

European patent application 12006827.5;

US Provisional patent application no.

61/810802 Other patent applications pending

1055507004

DCR C1521 Rev. AG