

Automotive Sensor Products

Linear Position Sensor – Hall



Figure 1: Linear Position Sensor

Features

- ◆ Magnetically operated position sensor
- ◆ Linear PWM outputs
- ◆ Programmable sensor – custom option
- ◆ Separate magnet assembly as actuator
- ◆ Large air gap operating
- ◆ Non-contact measuring

Benefits

- ◆ Robust construction makes this sensor well suited to harsh environments
- ◆ Magnetically operated non-contact sensing gives excellent life and reliability
- ◆ Ability to customize programming output states to customer needs

Applications

- ◆ Transmission fork position
- ◆ Linear stroke

General Description

The Hall Effect Linear Position Sensor detects the position of each fork in a DCT transmission. Each position sensor operates in a pair with one magnet actuator. There are four pairs in total to detect the fork position of gears 1~7 and reverse position.

Operation

Basic Principle

The sensor is a linear PWM output sensor which detects the position of moving parts. After programming, the sensor will output a linear PWM signal to reflect the position of the magnet assembly actuator.



Figure 2: Magnet Actuator



Figure 3: Linear Position Sensor

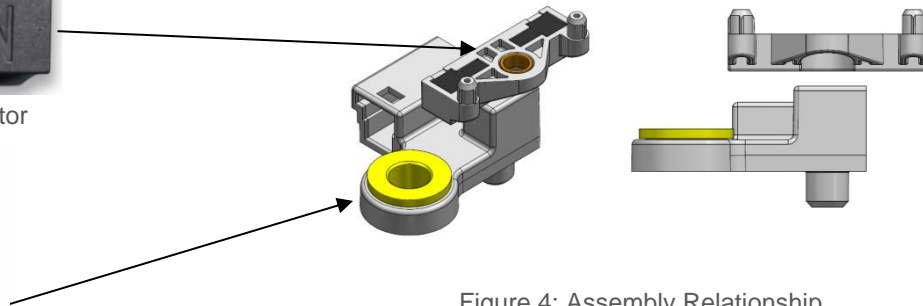

Figure 4: Assembly Relationship

Automotive Sensor Products

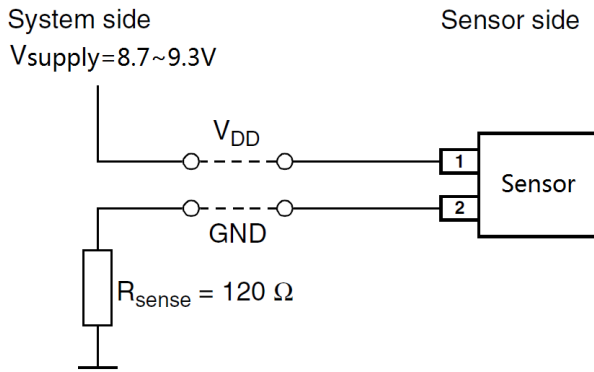

Figure 5: Typical Application Schematic Diagram

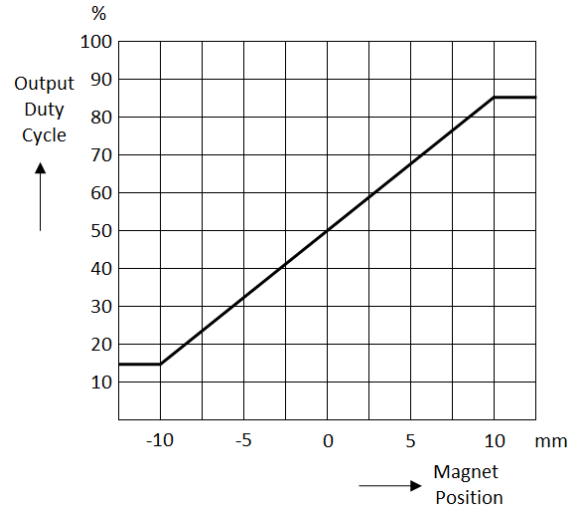

Figure 6: Output Curve

Packaging Options

Custom packaging can be provided to meet any need, please contact Littelfuse Engineering for details.

Automotive Sensor Products

Functional Characteristics

Parameter			
Type			
Hall Effect Sensor		Programmable	
Output		Linear PWM Duty Cycle	
Electrical			
Voltage Supply	Max.	9.3Vdc	
	Min.	8.7Vdc	
PWM Output Signal Current	Low	4.0 ~ 8.0mA	
	High	12.0~ 16.5mA	
PWM output Frequency		420~540Hz	
Magnet to Sensor Air Gap	Max.	2.3mm	
	Min.	4.7mm	
Magnet Linear Sensing Range		-10~+10mm	
Repeatability Across Temp Range		0.5%FS	
Sensor Output Performance (typical)	Air Gap	-10.0mm	+10.0mm
	2.3mm	15%DC	85%DC
	3.5mm	25%DC	75%DC
	4.7mm	33%DC	67%DC
PWM Output Signal Clamps	Min.	3%DC	
	Max.	97%DC	
Environmental/Mechanical			
Temperature	Operating	Celsius	-40° C to +140°C
	Storage	Celsius	-55°C to +150°C
Mechanical Shock	15ms ½ Sine	Max.	25g
Random Vibration	12 – 2000Hz	Max.	RMS MAX 4.2g

Littelfuse

Website: www.littelfuse.com
 Sales Support: ALL_Autosensors_Sales@littelfuse.com
 Technical Support: ALL_Autosensors_Tech@littelfuse.com

Information provided by Littelfuse is believed to be accurate and reliable.
 All rights reserved. Trademarks and registered trademarks are the property of their respective owners.
 Littelfuse products are designed for specific applications and should not be used for any purpose (including, without limitation, automotive applications) not expressly set forth in applicable Littelfuse product documentation. Warranties granted by Littelfuse shall be deemed void for products used for any purpose not expressly set forth in applicable Littelfuse product documentation. Littelfuse shall not be liable for any claims or damages arising out of products used in applications not expressly intended by Littelfuse as set forth in applicable Littelfuse product documentation.

ASP-MKT45-0021-AB