

THIS DRAWING AND THE INFORMATION CONTAINED WITHIN IT ARE CONFIDENTIAL AND MAY NOT BE COPIED OR DISCLOSED WITHOUT THE WRITTEN PERMISSION OF LITTELFUSE.

REV	DATE	DESCRIPTION	DESIGNED	CHECKED
A	08/02/2018	ISSUED	F. Gasparini	C. Crovetti

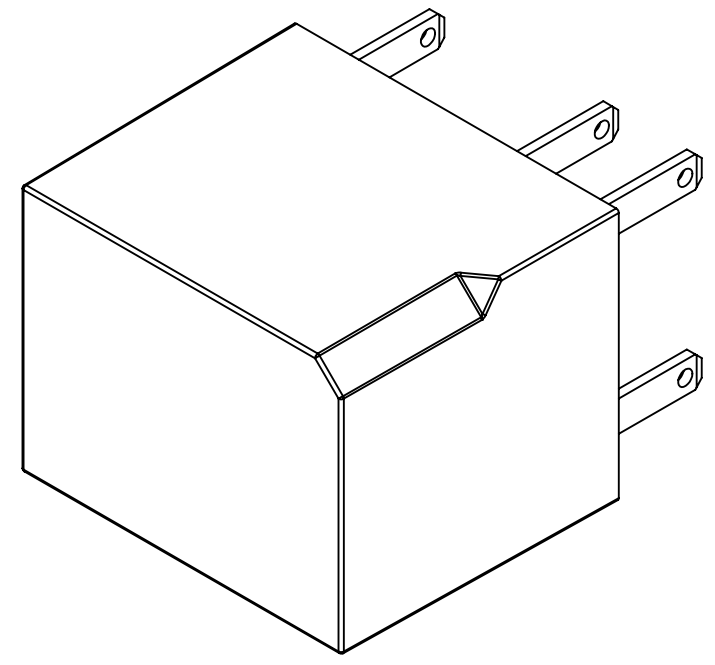
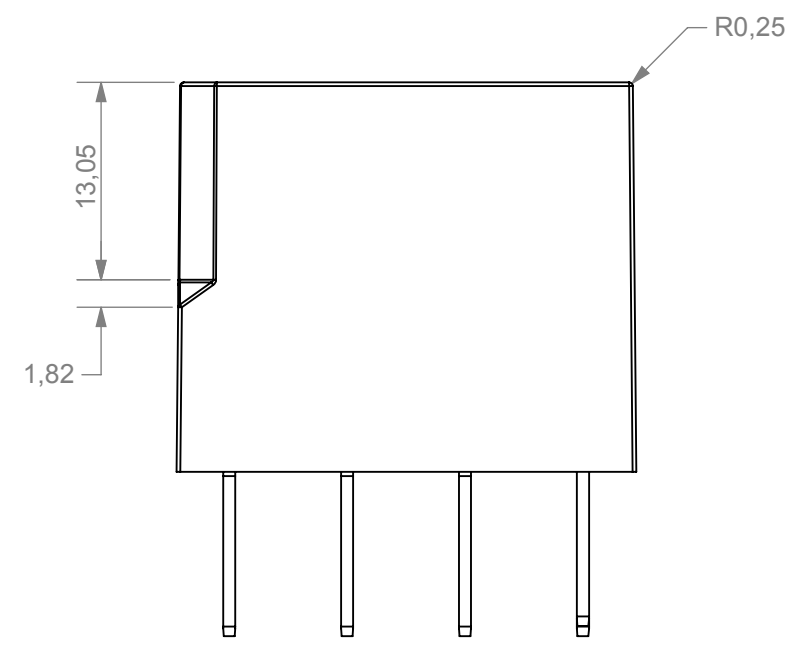
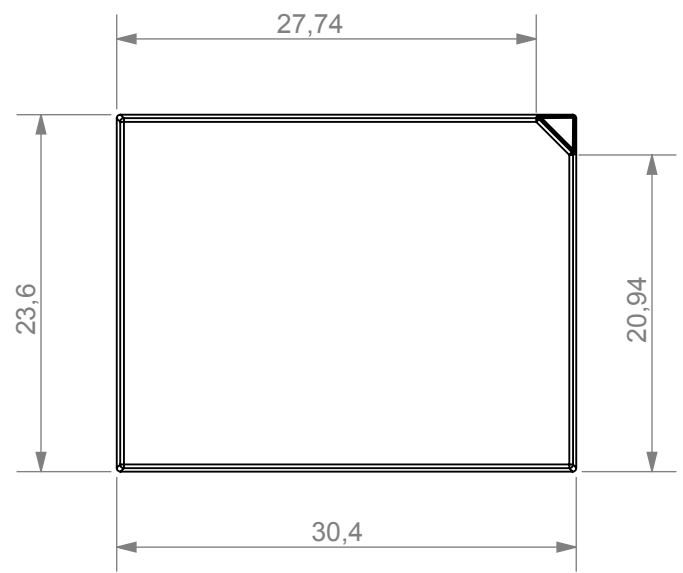
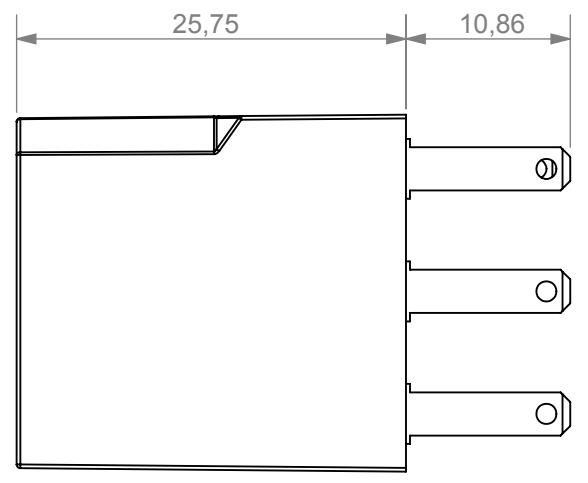
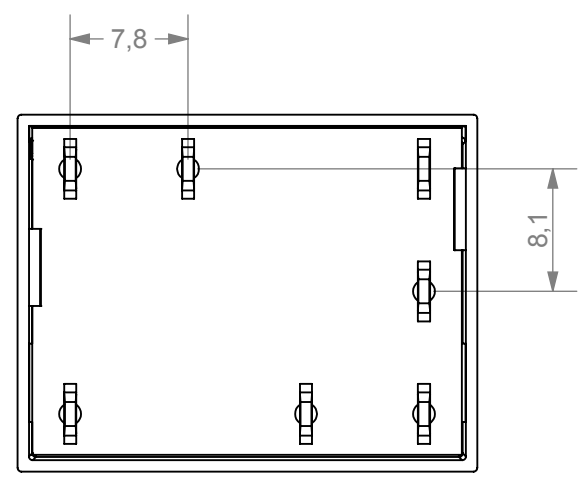

MRS part n° 1.135.330.00

INTERPRET DRAWING TO ANSI/ASME Y14.5-1994.	
●	DENOTES PRODUCTS CRITICAL CHARACTERISTICS
CPK	DENOTES CPK DIMENSIONS MINIMUM CPK VALUE
ST	DENOTES A CHARACTERISTIC THAT PROVIDES AN INDICATION OF PROCESS PERFORMANCE. PROCEDURE FOR MEASUREMENT AND TRACKING TO BE DEFINED IN LITTELFUSE INSPECTION INSTRUCTIONS
CP	DENOTES CP DIMENSIONS, -MINIMUM CP VALUE MUST BE WITHIN THE DIMENSIONAL LIMITATIONS SHOWN ON DRAWING AND INITIALLY LOCATED TO ALLOW FOR MAXIMUM TOOL LIFE
TOLERANCES UNLESS OTHERWISE SPECIFIED ONE PLACE DECIMAL ± 0.5 THREE PLACES DECIMAL ± 0.100 TWO PLACES DECIMAL ± 0.20 ANGULAR ± 2°	
DRAWN	NAME: F. Gasparini DATE: 07/02/2018
Littelfuse Expertise Applied Answers Delivered	
TITLE MicroPlex SSR30	
FIRST ANGLE PROJECTION	
SIZE: A3	DWG. NO. LFMCRPLX005 REV. A
DO NOT SCALE DRAWING	SCALE 2:1 SHEET 1 OF 1