

Revision Control Record

Rev.	Description of Change	ECN No.	Date
E	REVISED DRAWING, SSR	07035	1/25/07
F	BOM CHANGE	09588	01/15/10

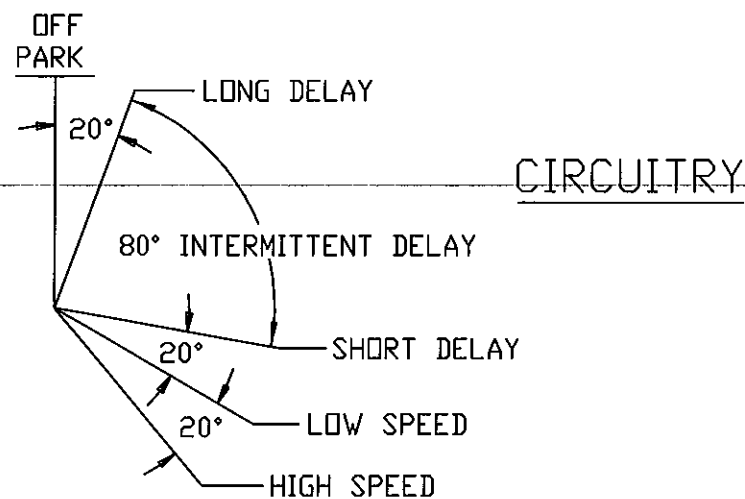

CIRCUITRY

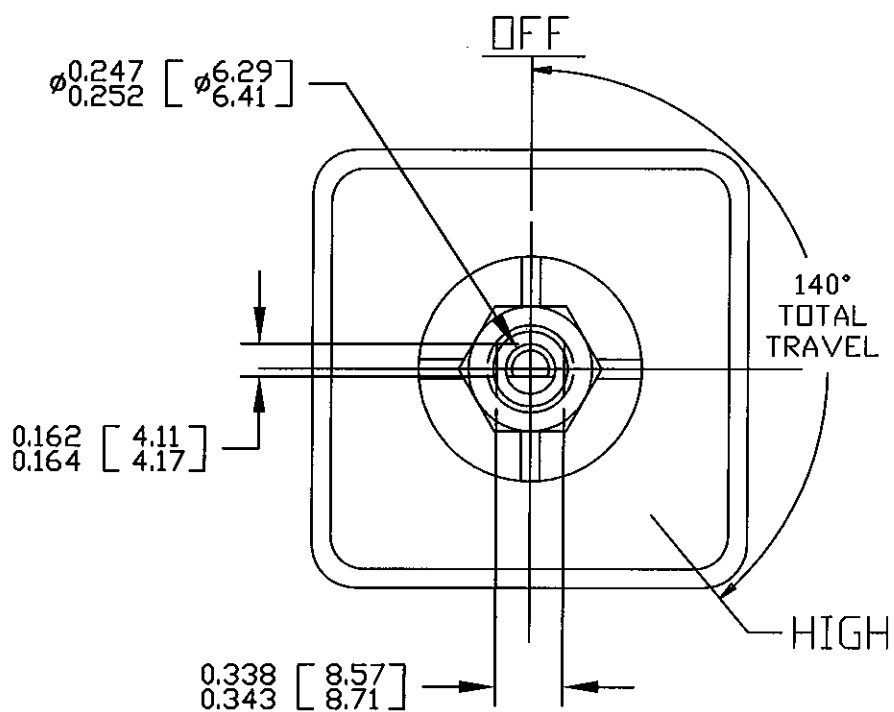

FRONT VIEW OF KNOB

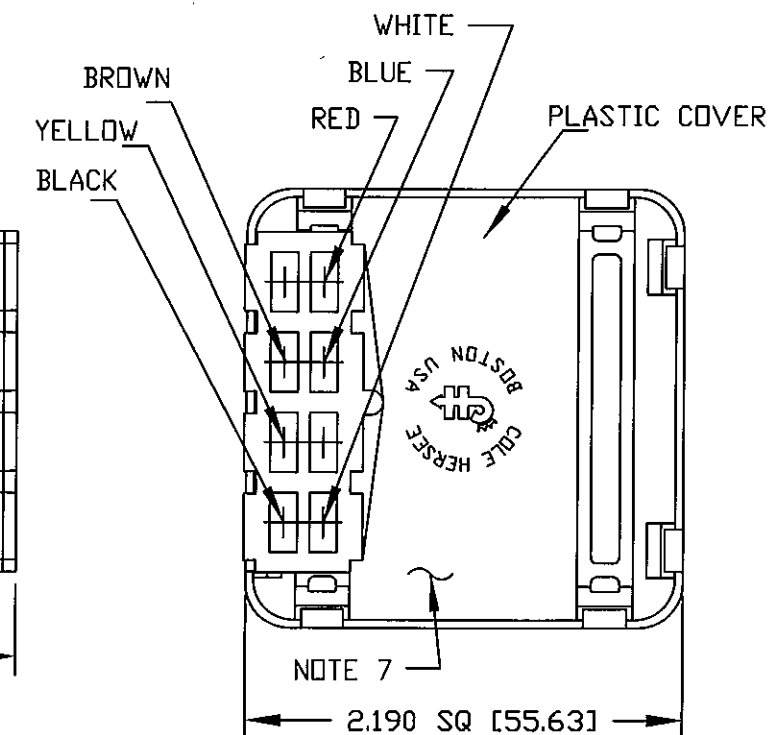
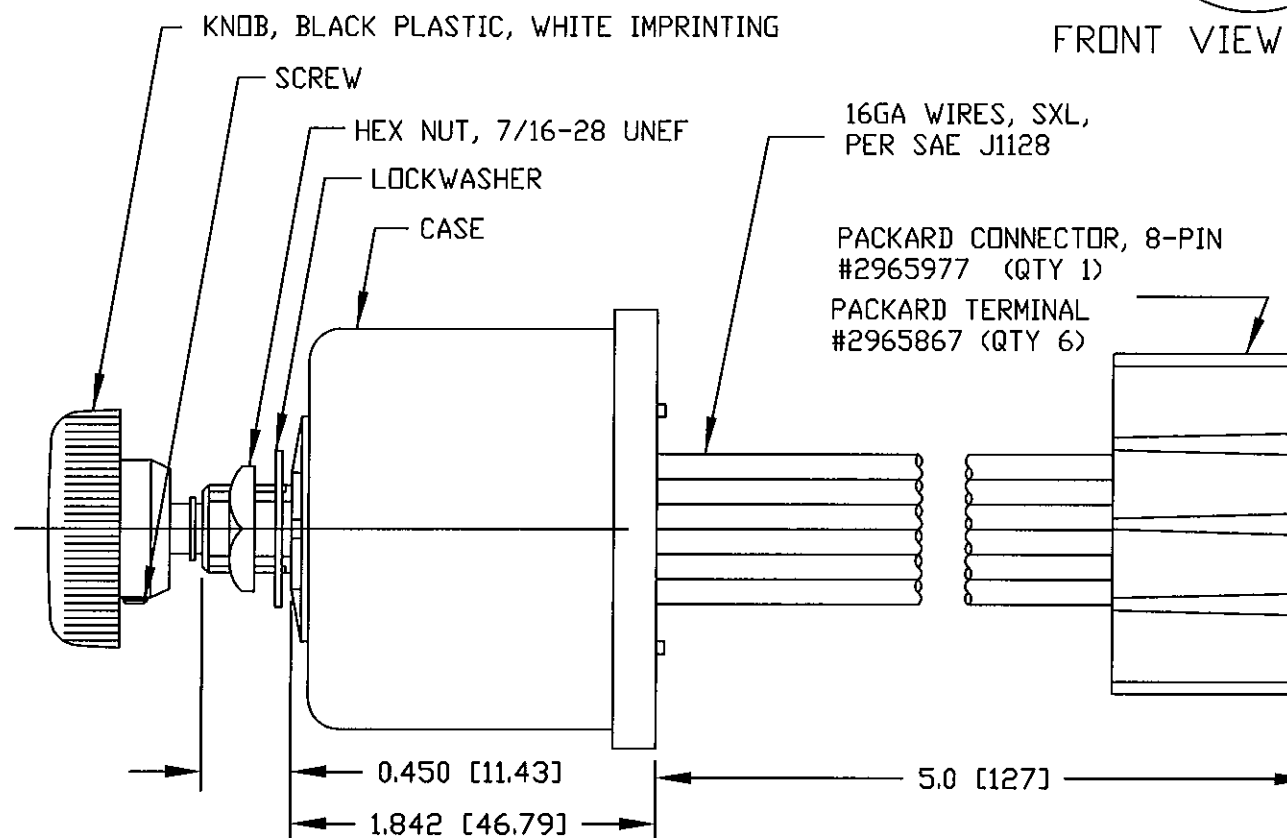

NOTES:

- DESIGNED FOR 12V SYSTEM, SINGLE MOTOR, DYNAMIC AND NON-DYNAMIC PARK. TO BE USED WITH PERMANENT MAGNET MOTOR, NEGATIVE GROUND ONLY.
- PUSH TO WASH FUNCTION: RESULTS IN 2 TO 3 WIPES AFTER RELEASE OF PUSH SWITCH.
- RATING: VOLTAGE OPERATING RANGE 9VDC TO 16VDC
 ROTARY SWITCH ACTUATION 20,000 CYCLES MINIMUM.
 MOTOR DRIVE: 15 AMPS CONTINUOUS. START-UP/STALL/LOCKED-ROTOR 50 AMPS. SHORT-CIRCUIT PROOF.
 WASHER CIRCUIT 3 AMPS, PUSH SWITCH 20,000 CYCLES MINIMUM.
- MICROPROCESSOR CONTROLLED, SOLID-STATE RELAY, CURRENT LIMIT SENSE CIRCUIT, REVERSE POLARITY PROTECTED
- CONFORMS TO SAE J1455:
 - GENERAL HEAVY DUTY TRUCK ELECTRICAL ENVIRONMENT.
 - STEADY-STATE ELECTRICAL CHARACTERISTICS.
 - TRANSIENT, NOISE AND ELECTROSTATIC CHARACTERISTICS.
 - ENVIRONMENTAL EXTREMES BY LOCATION.
 - INTERIOR-FORWARD.
- ALL DIMENSIONS ARE REFERENCE ONLY UNLESS NOTED OTHERWISE.
- COLE HERSEE PART NUMBER, REVISION, & DATE CODE STAMPED IN WHITE.

COLOR	FUNCTION
WHITE	MOTOR HIGH SPEED
YELLOW	MOTOR LOW SPEED
BLACK	GROUND (0V)
BROWN	WASHER PUMP
RED	VBB (12V)
BLUE	MOTOR PARK

Tolerances Unless otherwise specifically noted, the following are default tolerances:
 * 2-place Decimal Dimensions +/- .02"
 * 3-place Decimal Dimensions +/- .005"
 * Angular Dimensions +/- 1.0 Deg.
 * Metric: Refer to equivalent English Dimension Tolerance
 >>> NOTE: All tolerances are Non-Cumulative. <<<

Dimensional Units All dimensions are expressed in inches except those shown in brackets (xxx) are expressed in millimeters

"REF." or an Asterisk (*) = Non-Toleranced Reference Dimension, shown for clarification purposes only.

PROPRIETARY INFORMATION This Engineering Drawing, and the information contained herein, is proprietary to Cole Hersee Company and may not be disclosed, re-produced, or in any other way transferred or communicated to any other party without the express written consent of an authorized representative of Cole Hersee Company.

DESIGN CONTROL It is the responsibility of the individual using / referencing this drawing to assure that the noted design revision level agrees with the revision level of the Controlled Document (Master Drawing). This is a NON-CONTROLLED DOCUMENT unless otherwise specifically noted.

DO NOT SCALE - Dimensional variation may occur during printing / reproduction.

Special Characteristics:

- CC Critical Characteristic, relating to Safety and/or Regulatory Compliance
- X Significant Characteristic relating to Process Control (SPC)
- KC Control Dimension relating to Form - Fit - Function as defined by Cole Hersee Company and/or the Customer

(Note that the identification of any Characteristics as being "Special" does not alter the requirement that ALL specified dimensions & tolerances must be met.)

Cole Hersee Co.
 20 Old Colony Ave., South Boston, MA, 02127
 Phn: 617-268-2100 Web: www.colehersee.com

Description: WINDSHIELD WIPER CONTROLLER, UNIVERSAL, 12V

Drawing / Part No.: 75600

Current Rev.: F

Revision Control Record

Rev.	Description of Change	ECN No.	Date
E	ADDED NOTE TO COVER VIEW	03274	7/24/03
F	CHANGE TO SSR PCB	07060	02/16/07
G	BOM CHANGE	09587	01/13/10

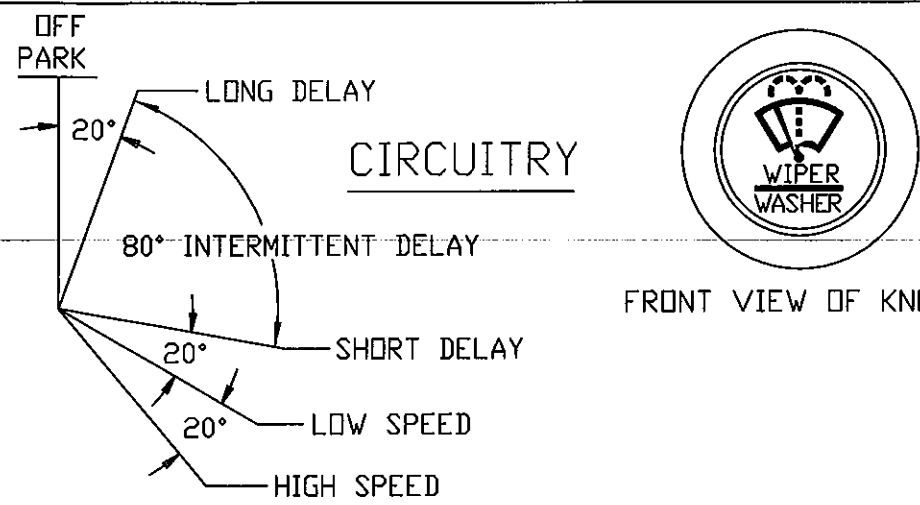

FRONT VIEW OF KNOB

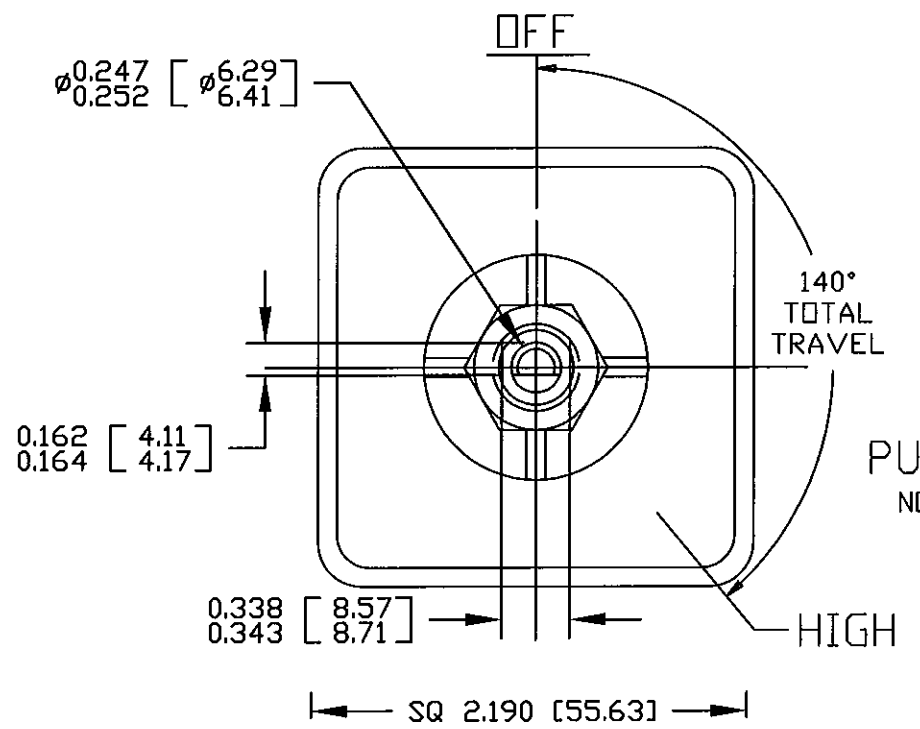

PUSH TO WASH
NOTE 2

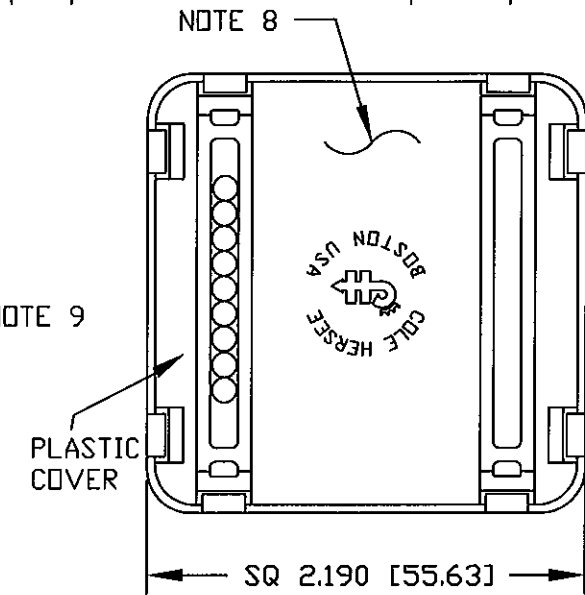
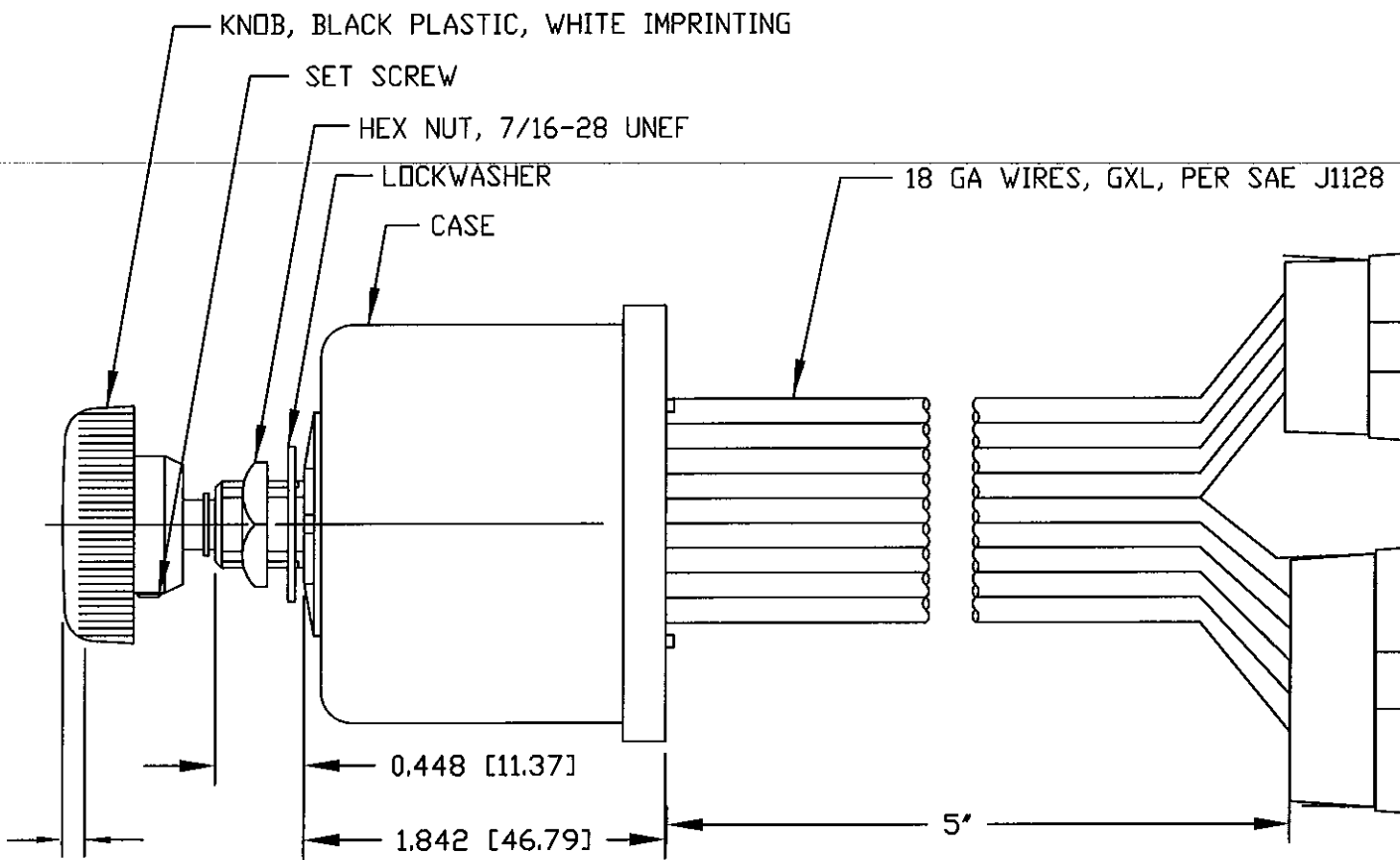

NOTES:

- DESIGNED FOR 12V SYSTEM, DUAL MOTOR, DYNAMIC AND NON-DYNAMIC PARK.
- PUSH TO WASH FUNCTION RESULTS IN 3 WIPES AFTER RELEASE OF PUSH SWITCH.
- RATING: VOLTAGE OPERATING RANGE 9VDC TO 16VDC
 ROTARY SWITCH ACTUATION 20,000 CYCLES MINIMUM.
 MOTOR DRIVE: 10 AMPS PER MOTOR CONTINUOUS. START-UP/STALL/LOCKED-ROTOR 30 AMPS. SHORT-CIRCUIT PROOF.
 WASHER CIRCUIT 3 AMPS, PUSH SWITCH 20,000 CYCLES MINIMUM.
- MICROPROCESSOR CONTROLLED, SOLID-STATE RELAY, CURRENT LIMIT SENSE CIRCUIT, REVERSE POLARITY PROTECTED
- CONFORMS TO SAE J1455:
 4.11 GENERAL HEAVY DUTY TRUCK ELECTRICAL ENVIRONMENT.
 4.11.1 STEADY-STATE ELECTRICAL CHARACTERISTICS.
 4.11.2 TRANSIENT, NOISE AND ELECTROSTATIC CHARACTERISTICS.
- INTERMITTENT DELAYS: 1, 2, 4, 7, 11 AND 16 SECONDS
- ALL DIMENSIONS ARE REFERENCE ONLY UNLESS NOTED OTHERWISE.
- COLE HERSEE PART NUMBER, REVISION, & DATE CODE STAMPED IN WHITE ON REAR PLASTIC COVER.
- CONNECTORS, DELPHI: 6-PIN, PART# 2977042 (QTY 1); 4-PIN, PART# 6294544 (QTY 1)
 TERMINALS, DELPHI: PART#2965439 (QTY 10)

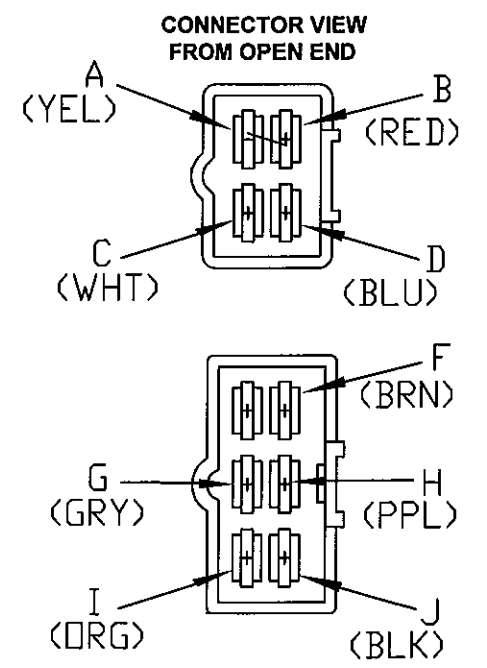

COLOR	FUNCTION	TERMINAL
YELLOW	LOW-SPEED MOTOR #1	A
RED	VBB (12V POWER)	B
WHITE	HIGH-SPEED MOTOR#1	C
BLUE	PARK MOTOR #1	D
BROWN	WASHER	F
GREY	HIGH-SPEED MOTOR #2	G
PURPLE	PARK MOTOR #2	H
ORANGE	LOW-SPEED MOTOR #2	I
BLACK	GROUND (0V)	J

Tolerances Unless otherwise specifically noted, the following are default tolerances:
 * 2-place Decimal Dimensions +/- .02"
 * 3-place Decimal Dimensions +/- .005"
 * Angular Dimensions +/- 1.0 Deg.
 * Metric: Refer to equivalent English Dimension Tolerance
 >>> NOTE: All tolerances are Non-Cumulative. <<<

Dimensional Units All dimensions are expressed in inches except those shown in brackets (xxx) are expressed in millimeters

"REF." or an Asterisk (*) = Non-Toleranced Reference Dimension, shown for clarification purposes only.

Used On or Ref.: **EX28333** Scale: **1:1**

PROPRIETARY INFORMATION This Engineering Drawing, and the information contained herein, is proprietary to Cole Hersee Company and may not be disclosed, re-produced, or in any other way transferred or communicated to any other party without the express written consent of an authorized representative of Cole Hersee Company.

DESIGN CONTROL It is the responsibility of the Individual using / referencing this drawing to assure that the noted design revision level agrees with the revision level of the Controlled Document (Master Drawing). This is a NON-CONTROLLED DOCUMENT unless otherwise specifically noted.

DO NOT SCALE - Dimensional variation may occur during printing / reproduction.

Drawn **JCS** Date **10/10/06**
 By: Drawn:

Special Characteristics:

- Critical Characteristic, relating to Safety and/or Regulatory Compliance
- Significant Characteristic relating to Process Control (SPC)
- Control Dimension relating to Form - Fit - Function as defined by Cole Hersee Company and/or the Customer

(Note that the identification of any Characteristics as being "Special" does not alter the requirement that ALL specified dimensions & tolerances must be met.)

Responsible Engineer: **JCS** Pg. **1**

Cole Hersee Co.
 20 Old Colony Ave., South Boston, MA, 02127
 Phn: 617-268-2100 Web: www.colehersee.com

Description:
WINDSHIELD WIPER CONTROLLER, DUAL-MOTOR, W/ WIPER ENABLE, 12V, SSR

Drawing / Part No.: **75600-01** Current Rev.: **G**



Revision Control Record

Rev.	Description of Change	ECN No.	Date
L	REVISED DRAWING, SSR	07035	1/24/07
M	EDIT NOTE 7	09257	04/21/09
N	BOM CHANGE	09588	01/15/10

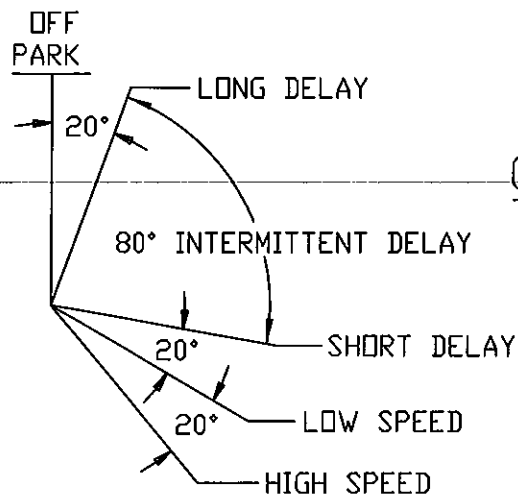

CIRCUITRY

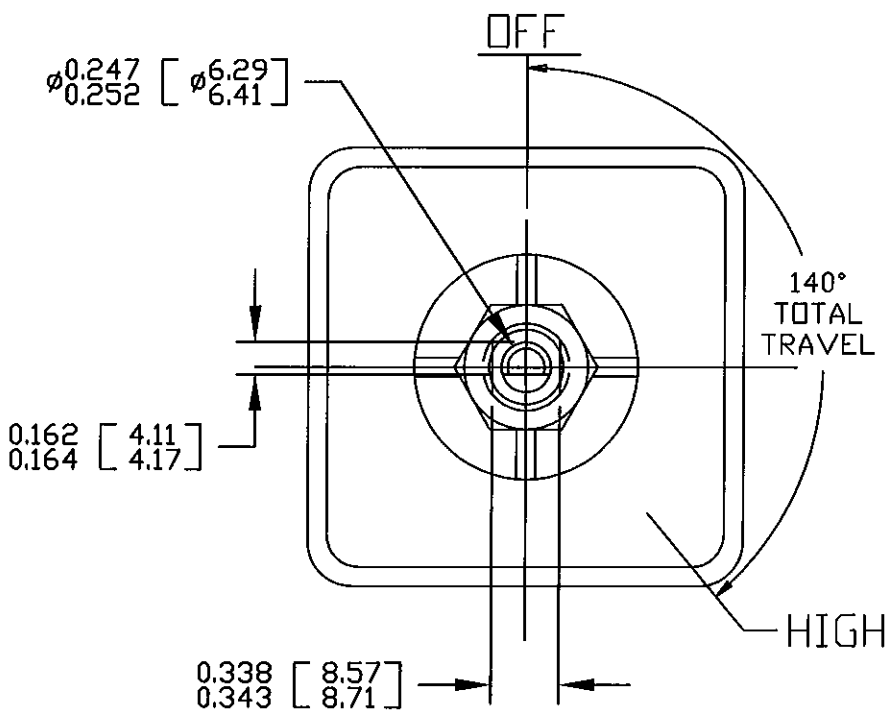

FRONT VIEW OF KNOB

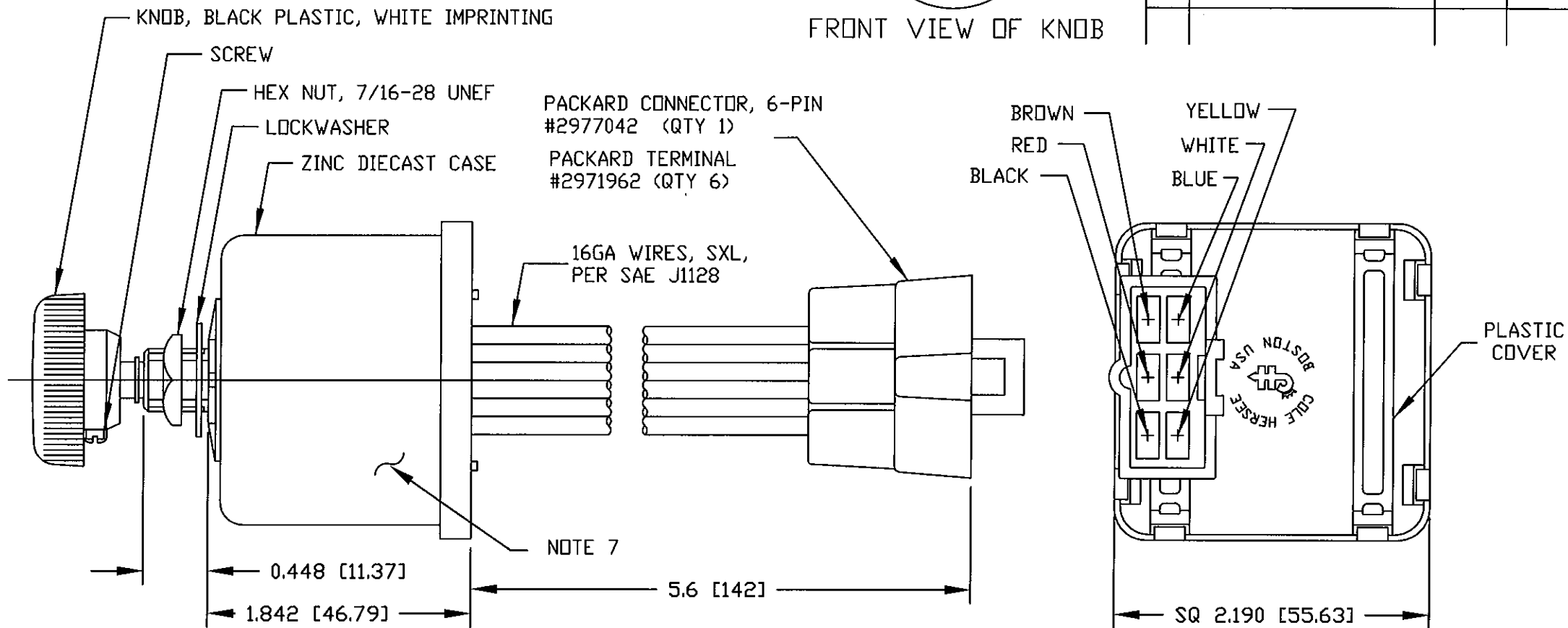

- NOTES:**
- DESIGNED FOR 12V SYSTEM, SINGLE MOTOR, DYNAMIC AND NON-DYNAMIC PARK. TO BE USED WITH PERMANENT MAGNET MOTOR, NEGATIVE GROUND ONLY.
 - PUSH TO WASH FUNCTION: RESULTS IN 2 TO 3 WIPES AFTER RELEASE OF PUSH SWITCH.
 - RATING: VOLTAGE OPERATING RANGE 9VDC TO 16VDC
 ROTARY SWITCH ACTUATION 20,000 CYCLES MINIMUM.
 MOTOR DRIVE: 15 AMPS CONTINUOUS. START-UP/STALL/LOCKED-ROTOR 50 AMPS. SHORT-CIRCUIT PROOF.
 WASHER CIRCUIT 3 AMPS, PUSH SWITCH 20,000 CYCLES MINIMUM.
 - MICROPROCESSOR CONTROLLED, SOLID-STATE RELAY, CURRENT LIMIT SENSE CIRCUIT, REVERSE POLARITY PROTECTED
 - CONFORMS TO SAE J1455:
 - GENERAL HEAVY DUTY TRUCK ELECTRICAL ENVIRONMENT.
 - STEADY-STATE ELECTRICAL CHARACTERISTICS.
 - TRANSIENT, NOISE AND ELECTROSTATIC CHARACTERISTICS.
 - ENVIRONMENTAL EXTREMES BY LOCATION.
 - INTERIOR-FORWARD.
 - ALL DIMENSIONS ARE REFERENCE ONLY UNLESS NOTED OTHERWISE.
 - COLE HERSEE PART NUMBER, REVISION, & DATE CODE MARKED AT RANDOM ON CASE.

COLOR	FUNCTION
WHITE	MOTOR HIGH SPEED
YELLOW	MOTOR LOW SPEED
RED	VBB (+12V)
BROWN	WASHER PUMP
BLACK	GROUND (0V)
BLUE	MOTOR PARK

Tolerances Unless otherwise specifically noted, the following are default tolerances:
 * 2-place Decimal Dimensions +/- .02"
 * 3-place Decimal Dimensions +/- .005"
 * Angular Dimensions +/- 1.0 Deg.
 * Metric: Refer to equivalent English Dimension Tolerance
 >>> NOTE: All tolerances are Non-Cumulative. <<<

Dimensional Units All dimensions are expressed in inches except those shown in brackets (xxx) are expressed in millimeters

"REF." or an Asterisk (*) = Non-Toleranced Reference Dimension, shown for clarification purposes only.

Used On or Ref.: **EX26541** Scale: **1:1**

PROPRIETARY INFORMATION This Engineering Drawing, and the information contained herein, is proprietary to Cole Hersee Company and may not be disclosed, re-produced, or in any other way transferred or communicated to any other party without the express written consent of an authorized representative of Cole Hersee Company.

DESIGN CONTROL It is the responsibility of the individual using / referencing this drawing to assure that the noted design revision level agrees with the revision level of the Controlled Document (Master Drawing). This is a NON-CONTROLLED DOCUMENT unless otherwise specifically noted.

DO NOT SCALE - Dimensional variation may occur during printing / reproduction.

Drawn By: **DPS** Date Drawn: **1/23/07**

Special Characteristics:

- Critical Characteristic, relating to Safety and/or Regulatory Compliance
- Significant Characteristic relating to Process Control (SPC)
- Control Dimension relating to Form - Fit - Function as defined by Cole Hersee Company and/or the Customer

(Note that the Identification of any Characteristics as being "Special" does not alter the requirement that ALL specified dimensions & tolerances must be met.)

Responsible Engineer: **JCS** Pg. **1**

Cole Hersee Co.
 20 Old Colony Ave., South Boston, MA, 02127
 Phn: 617-268-2100 Web: www.colehersee.com

Description: WINDSHIELD WIPER CONTROLLER, UNIVERSAL, 12V

Drawing / Part No.: **75600-02** **Current Rev.:** **N**

Revision Control Record

Rev.	Description of Change	ECN No.	Date
L	CHANGE BOM	09588	01/15/10
M	CHANGE NOTE 3	13054	02/07/13

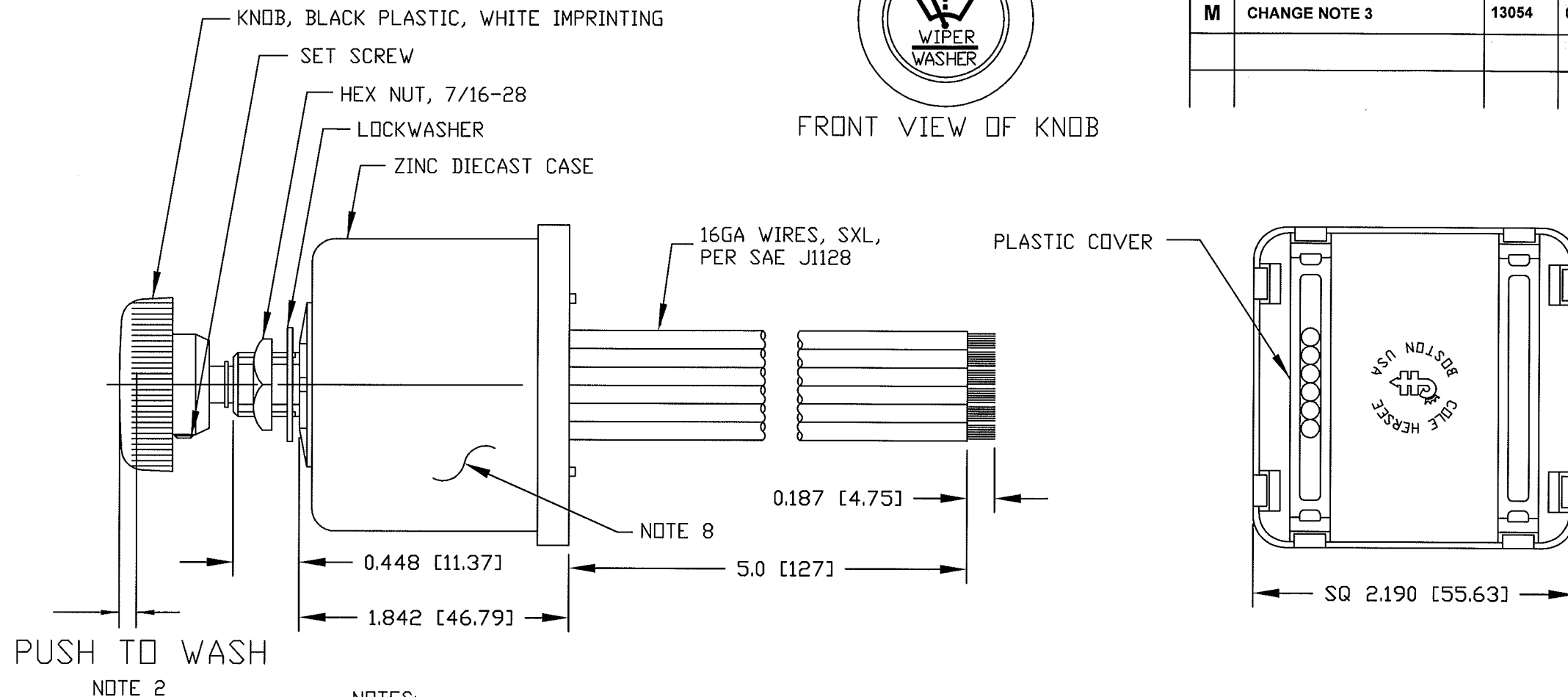
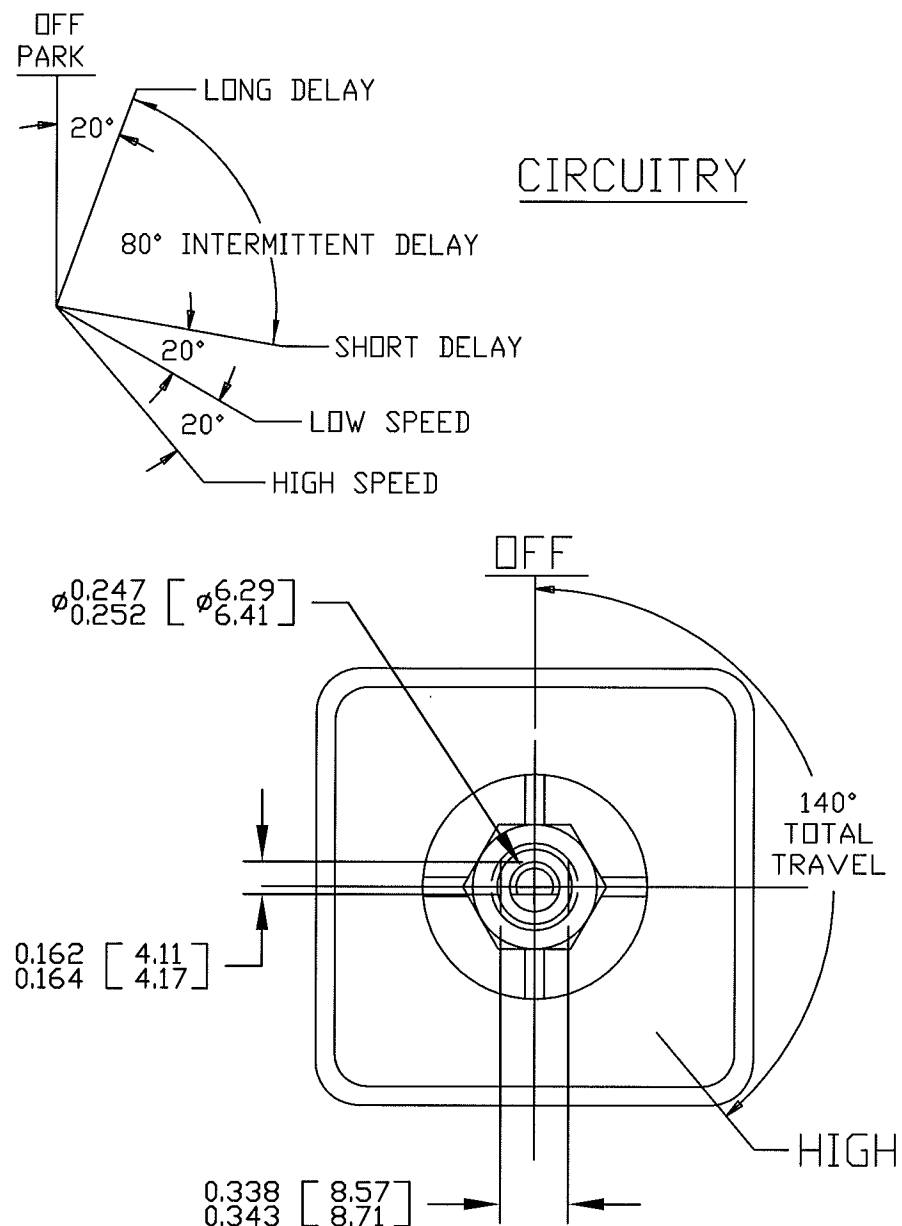

- NOTES:
- DESIGNED FOR 12V SYSTEM, SINGLE MOTOR, DYNAMIC AND NON-DYNAMIC PARK. TO BE USED WITH PERMANENT MAGNET MOTOR, NEGATIVE GROUND ONLY.
 - PUSH TO WASH FUNCTION: RESULTS IN 2 TO 3 WIPES AFTER RELEASE OF PUSH SWITCH.
 - RATING: VOLTAGE OPERATING RANGE 9VDC TO 16VDC
ROTARY SWITCH ACTUATION 20,000 CYCLES MINIMUM.
MOTOR DRIVE: 15 AMPS CONTINUOUS. START-UP/STALL/LOCKED-ROTOR 50 AMPS. SHORT-CIRCUIT PROTECTED (M)
WASHER CIRCUIT 3 AMPS, PUSH SWITCH 20,000 CYCLES MINIMUM.
 - MICROPROCESSOR CONTROLLED, SOLID-STATE RELAY, CURRENT LIMIT SENSE CIRCUIT, REVERSE POLARITY PROTECTED
 - CONFORMS TO SAE J1455:
4.11 GENERAL HEAVY DUTY TRUCK ELECTRICAL ENVIRONMENT.
4.11.1 STEADY-STATE ELECTRICAL CHARACTERISTICS.
4.11.2 TRANSIENT, NOISE AND ELECTROSTATIC CHARACTERISTICS.
 - ENVIRONMENTAL EXTREMES BY LOCATION.
5.2 INTERIOR-FORWARD.
 - ALL STEEL PARTS PLATED
 - ALL DIMENSIONS ARE REFERENCE ONLY UNLESS NOTED OTHERWISE.
 - COLE HERSEE PART NUMBER, REVISION, & DATE CODE MARKED AT RANDOM ON CASE.

COLOR	FUNCTION
WHITE	MOTOR HIGH SPEED
YELLOW	MOTOR LOW SPEED
RED	VBB (+12V)
BROWN	WASHER PUMP
BLACK	GROUND (0V)
BLUE	MOTOR PARK

Tolerances Unless otherwise specifically noted, the following are default tolerances:
 * 2-place Decimal Dimensions +/- .02"
 * 3-place Decimal Dimensions +/- .005"
 * Angular Dimensions +/- 1.0 Deg.
 * Metric: Refer to equivalent English Dimension Tolerance
 >>> NOTE: All tolerances are Non-Cumulative. <<<

Dimensional Units All dimensions are expressed in inches except those shown in brackets (xxx) are expressed in millimeters

"REF." or an Asterisk (*) = Non-Toleranced Reference Dimension, shown for clarification purposes only.

Used On or Ref.: **EX28241** Scale: **1:1**

PROPRIETARY INFORMATION This Engineering Drawing, and the information contained herein, is proprietary to Cole Hersee Company and may not be disclosed, re-produced, or in any other way transferred or communicated to any other party without the express written consent of an authorized representative of Cole Hersee Company.

DESIGN CONTROL It is the responsibility of the individual using / referencing this drawing to assure that the noted design revision level agrees with the revision level of the Controlled Document (Master Drawing). This is a NON-CONTROLLED DOCUMENT unless otherwise specifically noted.

DO NOT SCALE - Dimensional variation may occur during printing / reproduction.

Drawn By: **JCS** Date Drawn: **1/9/07**

Special Characteristics:

- Critical Characteristic, relating to Safety and/or Regulatory Compliance
- Significant Characteristic relating to Process Control (SPC)
- Control Dimension relating to Form - Fit - Function as defined by Cole Hersee Company and/or the Customer

(Note that the identification of any Characteristics as being "Special" does not alter the requirement that ALL specified dimensions & tolerances must be met.)

Responsible Engineer: **JCS** Pg. **1**

Cole Hersee Co.
 20 Old Colony Ave., South Boston, MA, 02127
 Phn: 617-268-2100 Web: www.colehersee.com

Description: WINDSHIELD WIPER CONTROLLER, UNIVERSAL, 12V

Drawing / Part No.: **75600-04** Current Rev.: **M**

Revision Control Record

Rev.	Description of Change	ECN No.	Date
H	CHANGED TO SSR	07074	03/02/07
J	BOM CHANGE	09588	01/15/10

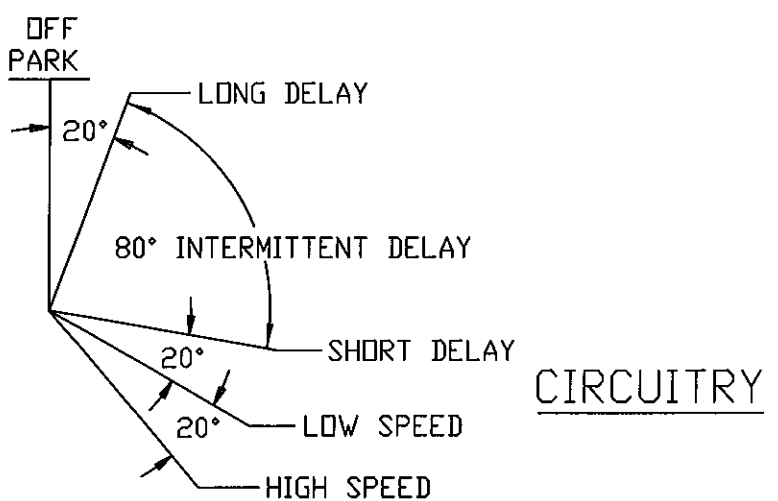
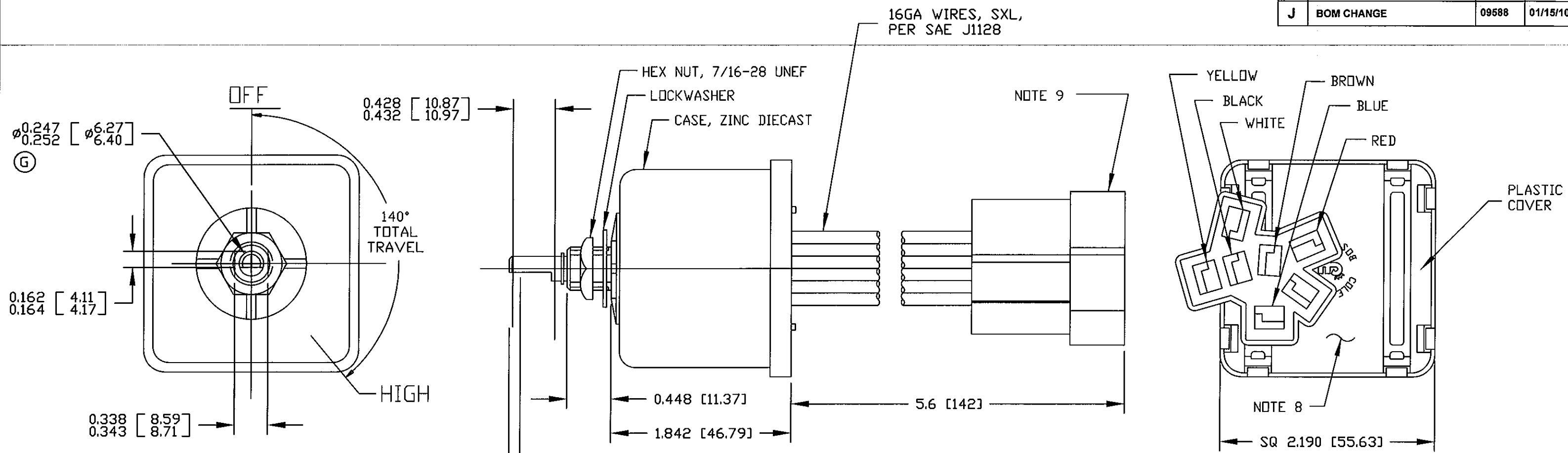

- NOTES:**
- DESIGNED FOR 12V SYSTEM, SINGLE MOTOR, DYNAMIC AND NON-DYNAMIC PARK. TO BE USED WITH PERMANENT MAGNET MOTOR, NEGATIVE GROUND ONLY.
 - PUSH TO WASH FUNCTION: RESULTS IN 2 TO 3 WIPES AFTER RELEASE OF PUSH SWITCH.
 - RATING: VOLTAGE OPERATING RANGE 9VDC TO 16VDC
 ROTARY SWITCH ACTUATION 20,000 CYCLES MINIMUM.
 MOTOR DRIVE: 15 AMPS CONTINUOUS. START-UP/STALL/LOCKED-ROTOR 50 AMPS. SHORT-CIRCUIT PROOF.
 WASHER CIRCUIT 3 AMPS, PUSH SWITCH 20,000 CYCLES MINIMUM.
 - MICROPROCESSOR CONTROLLED, SOLID-STATE RELAY, CURRENT LIMIT SENSE CIRCUIT, REVERSE POLARITY PROTECTED
 - CONFORMS TO SAE J1455:
 4.11 GENERAL HEAVY DUTY TRUCK ELECTRICAL ENVIRONMENT.
 4.11.1 STEADY-STATE ELECTRICAL CHARACTERISTICS.
 4.11.2 TRANSIENT, NOISE AND ELECTROSTATIC CHARACTERISTICS.
 - ENVIRONMENTAL EXTREMES BY LOCATION.
 5.2 INTERIOR-FORWARD.
 - ALL STEEL PARTS PLATED.
 - ALL DIMENSIONS ARE REFERENCE ONLY UNLESS NOTED OTHERWISE.
 - COLE HERSEE PART NUMBER, REVISION, & DATE CODE STAMPED IN WHITE.
 - CONNECTOR: DILL #059074. TERMINALS: DELPHI #12020126, QTY 6

COLOR	FUNCTION
WHITE	MOTOR HIGH SPEED
YELLOW	MOTOR LOW SPEED
BLACK	GROUND (0V)
BROWN	WASHER PUMP
RED	VBB (12V)
BLUE	MOTOR PARK

Tolerances Unless otherwise specifically noted, the following are default tolerances:
 * 2-place Decimal Dimensions +/- .02"
 * 3-place Decimal Dimensions +/- .005"
 * Angular Dimensions +/- 1.0 Deg.
 * Metric: Refer to equivalent English Dimension Tolerance
 >>> NOTE: All tolerances are Non-Cumulative. <<<

Dimensional Units All dimensions are expressed in inches except those shown in brackets (xxx) are expressed in millimeters

"REF." or an Asterisk (*) = Non-Toleranced Reference Dimension, shown for clarification purposes only.

PROPRIETARY INFORMATION This Engineering Drawing, and the information contained herein, is proprietary to Cole Hersee Company and may not be disclosed, re-produced, or in any other way transferred or communicated to any other party without the express written consent of an authorized representative of Cole Hersee Company.

DESIGN CONTROL It is the responsibility of the individual using / referencing this drawing to assure that the noted design revision level agrees with the revision level of the Controlled Document (Master Drawing). This is a NON-CONTROLLED DOCUMENT unless otherwise specifically noted.

DO NOT SCALE - Dimensional variation may occur during printing / reproduction.

Special Characteristics:

- CC Critical Characteristic, relating to Safety and/or Regulatory Compliance
- X Significant Characteristic relating to Process Control (SPC)
- KC Control Dimension relating to Form - Fit - Function as defined by Cole Hersee Company and/or the Customer

(Note that the identification of any Characteristics as being "Special" does not alter the requirement that ALL specified dimensions & tolerances must be met.)

Cole Hersee Co.
 20 Old Colony Ave., South Boston, MA, 02127
 Phn: 617-268-2100 Web: www.colehersee.com

Description: WINDSHIELD WIPER & WASHER SW. INTERMITTENT DELAY, 12V.D.C.

Drawing / Part No.: 75600-07

Current Rev.: J

MM	IN
4.75	.187
8.58	.338
11.43	.452
14.68	.578
18.58	.731
22.00	.866
25.62	1.010
29.00	1.142
32.00	1.260
35.00	1.378
38.00	1.496
41.00	1.614
44.00	1.732
47.00	1.850
50.00	1.968
53.00	2.086
56.00	2.204
59.00	2.322
62.00	2.440
65.00	2.558
68.00	2.676
71.00	2.794
74.00	2.912
77.00	3.030
80.00	3.148
83.00	3.266
86.00	3.384
89.00	3.502
92.00	3.620
95.00	3.738
98.00	3.856
101.00	3.974
104.00	4.092
107.00	4.210
110.00	4.328
113.00	4.446
116.00	4.564
119.00	4.682
122.00	4.800
125.00	4.918
128.00	5.036
131.00	5.154
134.00	5.272
137.00	5.390
140.00	5.508
143.00	5.626
146.00	5.744
149.00	5.862
152.00	5.980
155.00	6.098
158.00	6.216
161.00	6.334
164.00	6.452
167.00	6.570
170.00	6.688
173.00	6.806
176.00	6.924
179.00	7.042
182.00	7.160
185.00	7.278
188.00	7.396
191.00	7.514
194.00	7.632
197.00	7.750
200.00	7.868
203.00	7.986
206.00	8.104
209.00	8.222
212.00	8.340
215.00	8.458
218.00	8.576
221.00	8.694
224.00	8.812
227.00	8.930
230.00	9.048
233.00	9.166
236.00	9.284
239.00	9.402
242.00	9.520
245.00	9.638
248.00	9.756
251.00	9.874
254.00	9.992
257.00	10.110
260.00	10.228
263.00	10.346
266.00	10.464
269.00	10.582
272.00	10.700
275.00	10.818
278.00	10.936
281.00	11.054
284.00	11.172
287.00	11.290
290.00	11.408
293.00	11.526
296.00	11.644
299.00	11.762
302.00	11.880
305.00	11.998
308.00	12.116
311.00	12.234
314.00	12.352
317.00	12.470
320.00	12.588
323.00	12.706
326.00	12.824
329.00	12.942
332.00	13.060
335.00	13.178
338.00	13.296
341.00	13.414
344.00	13.532
347.00	13.650
350.00	13.768
353.00	13.886
356.00	14.004
359.00	14.122
362.00	14.240
365.00	14.358
368.00	14.476
371.00	14.594
374.00	14.712
377.00	14.830
380.00	14.948
383.00	15.066
386.00	15.184
389.00	15.302
392.00	15.420
395.00	15.538
398.00	15.656
401.00	15.774
404.00	15.892
407.00	16.010
410.00	16.128
413.00	16.246
416.00	16.364
419.00	16.482
422.00	16.600
425.00	16.718
428.00	16.836
431.00	16.954
434.00	17.072
437.00	17.190
440.00	17.308
443.00	17.426
446.00	17.544
449.00	17.662
452.00	17.780
455.00	17.898
458.00	18.016
461.00	18.134
464.00	18.252
467.00	18.370
470.00	18.488
473.00	18.606
476.00	18.724
479.00	18.842
482.00	18.960
485.00	19.078
488.00	19.196
491.00	19.314
494.00	19.432
497.00	19.550
500.00	19.668

75601-06

COLE-HERSEE CO.

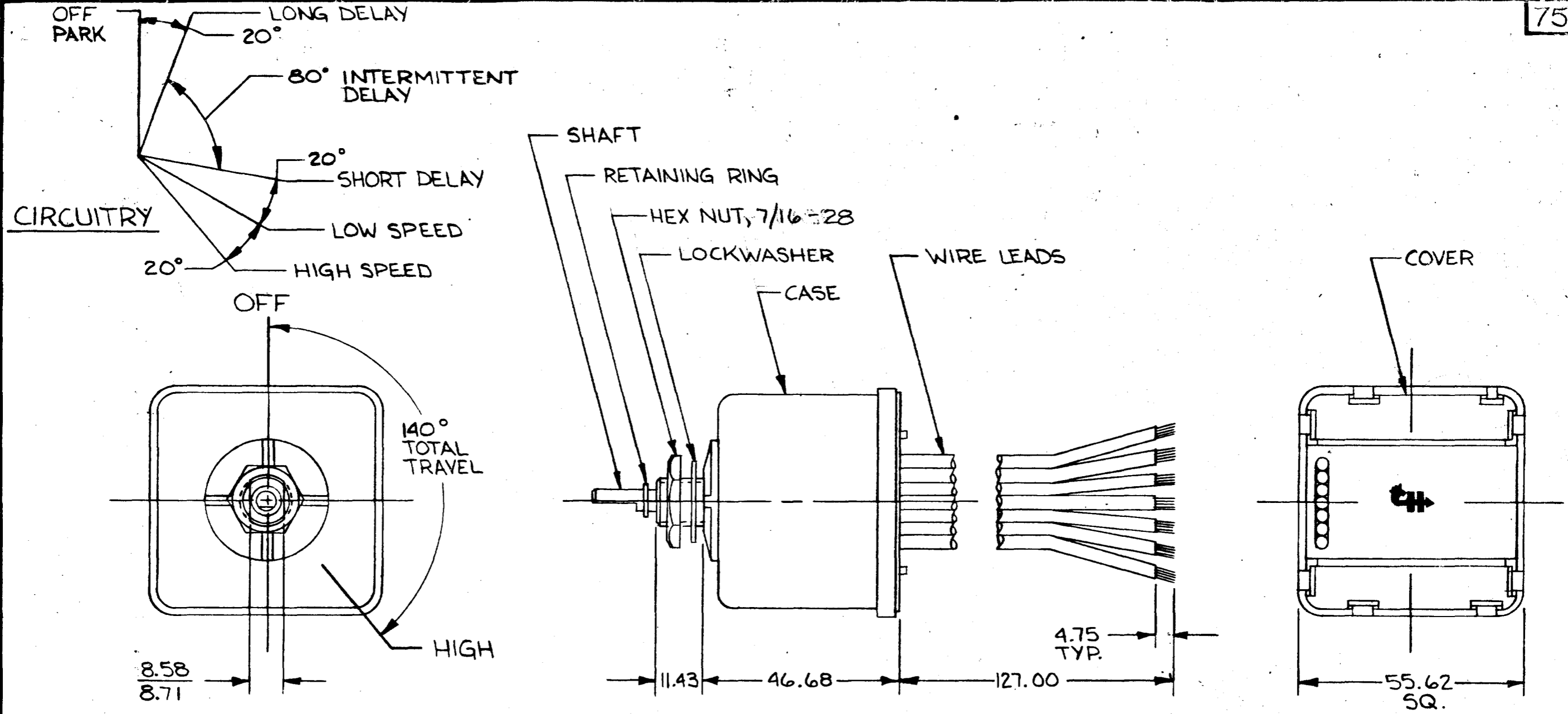

SWITCH CONNECTIONS		
COLOR	WIRE SIZE	CONNECT WIRE TO:
YELLOW	2.0 mm ² (14 GA)	MOTOR LOW SPEED TERMINAL
WHITE	2.0 mm ² (14 GA)	MOTOR HIGH SPEED TERMINAL
GREEN	2.0 mm ² (14 GA)	MOTOR PARK TERMINAL
BLACK	0.8 mm ² (18 GA)	GROUND (B-) THIS CONNECTION MUST BE MADE
BROWN	0.8 mm ² (18 GA)	WASHER PUMP (B+ TERMINAL)
RED	2.0 mm ² (14 GA)	B+ (THESE TWO WIRES MUST BE CONNECTED TOGETHER)
RED	0.8 mm ² (18 GA)	

- NOTES:
1. PUSH TO WASH, WASHER & WIPER CIRCUIT ACTIVATED (1-3 WIPES AFTER WASHER CIRCUIT IS DEACTIVATED).
 2. ALL STEEL PARTS PLATED.
 3. ALL DIMENSIONS ARE REF. ONLY.
 4. 12 VOLTS D.C.
 5. SEPARATE B+ AND GROUND CONNECTIONS MUST BE MADE TO THE WIPER MOTOR.

METRIC

LET.	WAS	DATE	BY	LET.	WAS	DATE	BY	MATERIAL	DRAWN	CHECKED	APPRVD.	SCALE	DATE DRAWN
								#	LZ			1:1	3-18-87
								FINISH					DATE BLUEPRINT
								TOLERANCES	WINDSHIELDWIPER & WASHER SWITCH PM MOTOR				75601-06
								DECIMAL ±					
								METRIC ±					

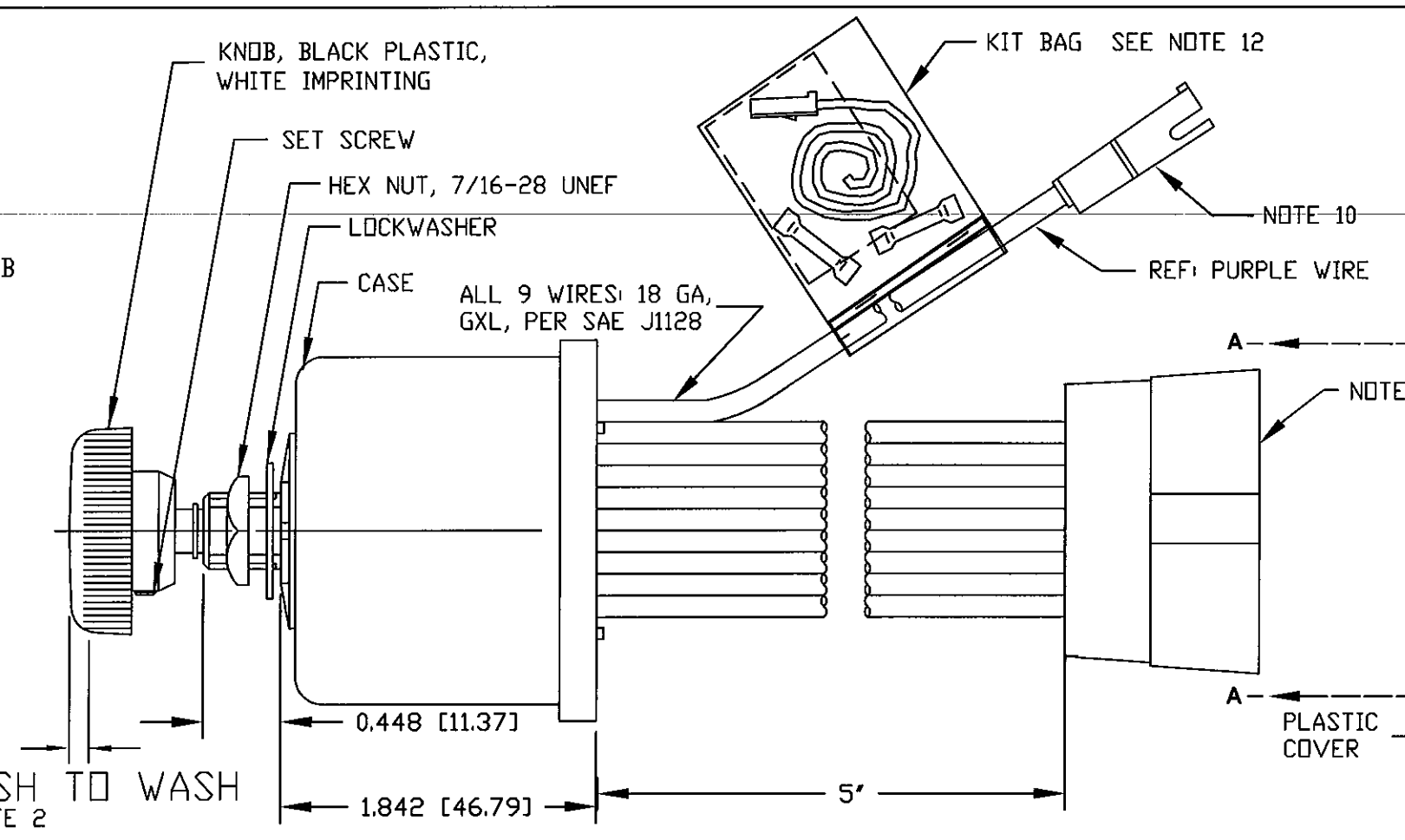
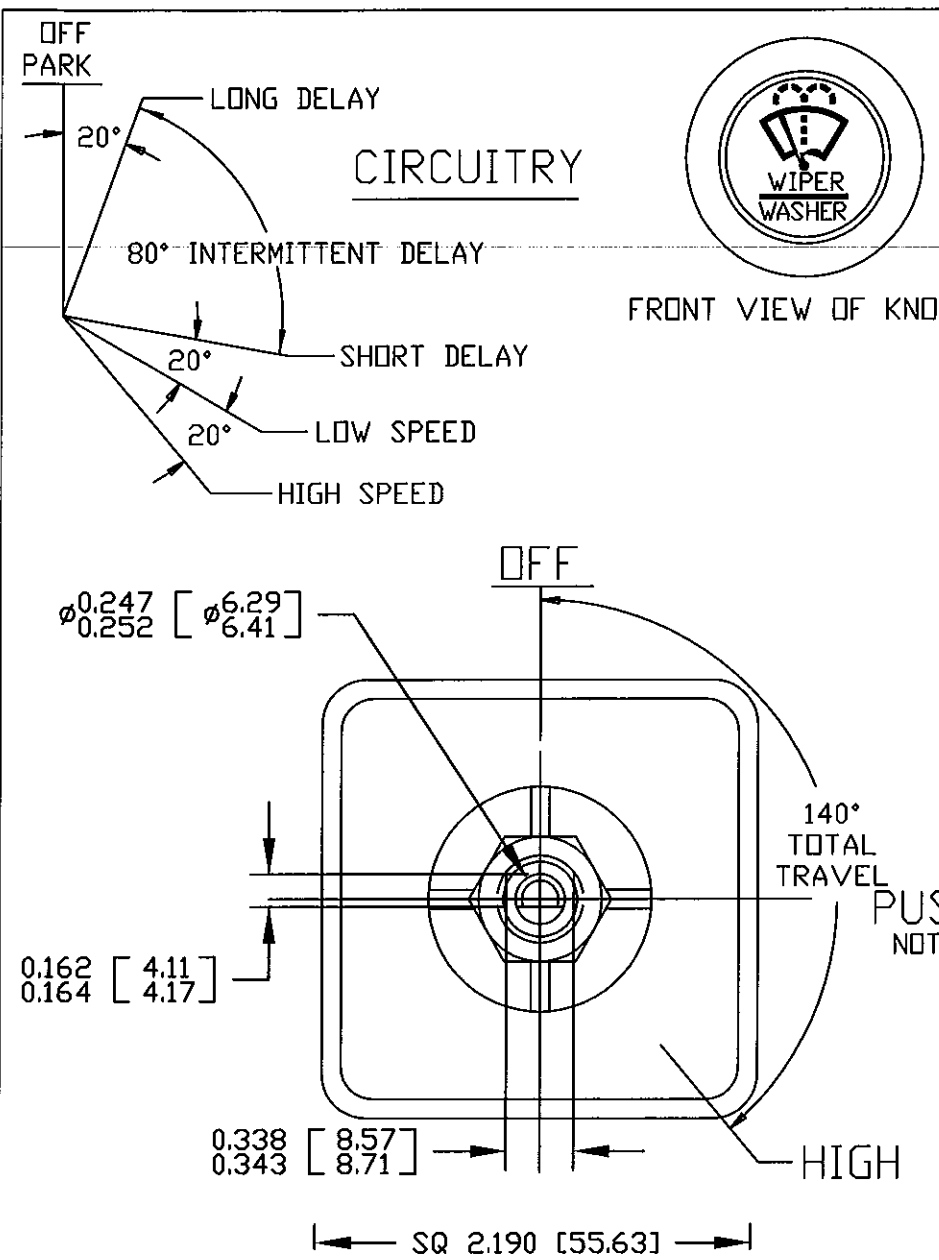

Revision Control Record			
Rev.	Description of Change	ECN No.	Date
A	NEW RELEASE	07475	12/04/07
B	SOFTWARE CHANGE	08085	01/31/08
C	BOM CHANGE	09587	01/13/10

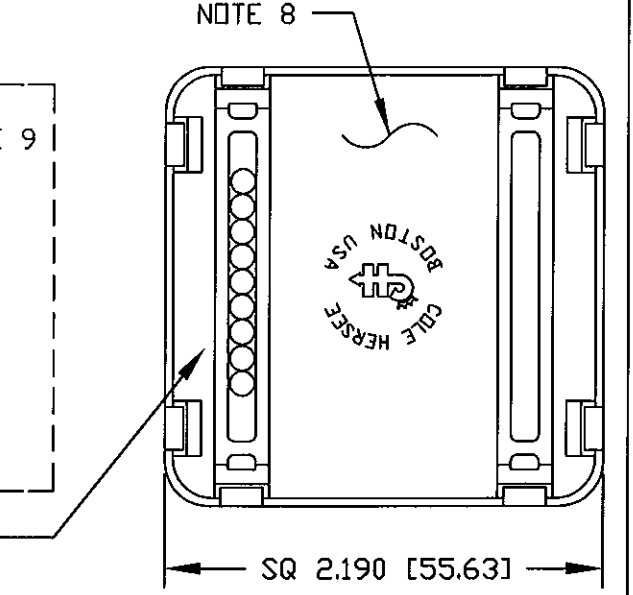

- NOTES:
- DESIGNED FOR 12V SYSTEM, DUAL MOTOR. MUST BE USED WITH NON-DYNAMIC PARK MOTORS ONLY.
 - PUSH TO WASH FUNCTION RESULTS IN 3 WIPES AFTER RELEASE OF PUSH SWITCH.
 - RATING: VOLTAGE OPERATING RANGE 9VDC TO 16VDC
 ROTARY SWITCH ACTUATION 20,000 CYCLES MINIMUM.
 MOTOR DRIVE: 10 AMPS PER MOTOR CONTINUOUS, START-UP/STALL/LOCKED-ROTOR 30 AMPS. SHORT-CIRCUIT PROOF.
 WASHER CIRCUIT 3 AMPS, PUSH SWITCH 20,000 CYCLES MINIMUM.
 - MICROPROCESSOR CONTROLLED, SOLID-STATE RELAY, CURRENT LIMIT SENSE CIRCUIT, REVERSE POLARITY PROTECTED
 - CONFORMS TO SAE J1455:
 4.11 GENERAL HEAVY DUTY TRUCK ELECTRICAL ENVIRONMENT.
 4.11.1 STEADY-STATE ELECTRICAL CHARACTERISTICS.
 4.11.2 TRANSIENT, NOISE AND ELECTROSTATIC CHARACTERISTICS.
 - INTERMITTENT DELAYS: 1, 2, 4, 7, 11 AND 16 SECONDS
 - ALL DIMENSIONS ARE REFERENCE ONLY UNLESS NOTED OTHERWISE.
 - COLE HERSEE PART NUMBER, REVISION, & DATE CODE STAMPED IN WHITE ON REAR PLASTIC COVER.
 - CONNECTOR, DELPHI: 8-PIN, PART# 2965972 (QTY 1)
 TERMINALS, DELPHI: 2965439 (QTY 8)
 - CONNECTOR, DELPHI: 1-PIN, PART# 8905650 (QTY 1)
 TERMINALS, DELPHI: 2965439 (QTY 1)
 - UNIT REQUIRES TWO SEPARATE WIRE CONNECTIONS TO MOTOR PARK SIGNALS.
 THIS MAY REQUIRE RE-WIRING VEHICLE HARNESS. DO NOT CONNECT PARK WIRES TOGETHER.
 NOTE THAT 1-PIN CONNECTOR (PURPLE WIRE) IS FOR PARK MOTOR #2.
 - WRAP PLASTIC BAG AROUND SWITCH PURPLE WIRE, FOLD AND STAPLE AS SHOWN.

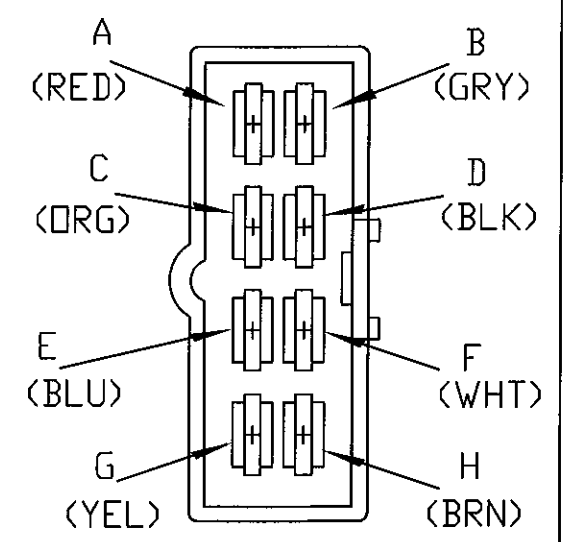

COLOR	FUNCTION	CONNECTOR	TERMINAL
RED	VBB (12V POWER)	8-PIN	A
GREY	HIGH-SPEED MOTOR #2	8-PIN	B
ORANGE	LOW-SPEED MOTOR #2	8-PIN	C
BLACK	GROUND (0V)	8-PIN	D
BLUE	PARK MOTOR #1 (SEE NOTE 11)	8-PIN	E
WHITE	HIGH-SPEED MOTOR#1	8-PIN	F
YELLOW	LOW-SPEED MOTOR #1	8-PIN	G
BROWN	WASHER	8-PIN	H
PURPLE	PARK MOTOR #2 (SEE NOTE 11)	1-PIN	

<p>Tolerances Unless otherwise specifically noted, the following are default tolerances: * 2-place Decimal Dimensions +/- .02" * 3-place Decimal Dimensions +/- .005" * Angular Dimensions +/- 1.0 Deg. * Metric: Refer to equivalent English Dimension Tolerance >>> NOTE: All tolerances are Non-Cumulative. <<<</p> <p>Dimensional Units All dimensions are expressed in inches except those shown in brackets (xxx) are expressed in millimeters</p> <p>"REF." or an Asterisk (*) = Non-Toleranced Reference Dimension, shown for clarification purposes only.</p>	<p>PROPRIETARY INFORMATION This Engineering Drawing, and the information contained herein, is proprietary to Cole Hersee Company and may not be disclosed, re-produced, or in any other way transferred or communicated to any other party without the express written consent of an authorized representative of Cole Hersee Company.</p> <p>DESIGN CONTROL It is the responsibility of the individual using / referencing this drawing to assure that the noted design revision level agrees with the revision level of the Controlled Document (Master Drawing). This is a NON-CONTROLLED DOCUMENT unless otherwise specifically noted.</p> <p>DO NOT SCALE - Dimensional variation may occur during printing / reproduction.</p>	<p>Special Characteristics:</p> <p>⊠ Critical Characteristic, relating to Safety and/or Regulatory Compliance</p> <p>⊞ Significant Characteristic relating to Process Control (SPC)</p> <p>Ⓚ Control Dimension relating to Form - Fit - Function as defined by Cole Hersee Company and/or the Customer</p> <p>(Note that the Identification of any Characteristics as being "Special" does not alter the requirement that ALL specified dimensions & tolerances must be met.)</p>	<p>Cole Hersee Co. 20 Old Colony Ave., South Boston, MA, 02127 Phn: 617-268-2100 Web: www.colehersee.com</p> <p>Description: WINDSHIELD WIPER CONTROLLER, DUAL-MOTOR, 12V, SSR, NON-DYNAMIC PARK MOTOR</p>
<p>Used On or Ref.: EX28333</p>	<p>Scale: 1:1</p>	<p>Drawn By: JCS</p>	<p>Date Drawn: 12/04/07</p>
<p>Responsible Engineer: JCS</p>	<p>Pg. 1</p>	<p>Drawing / Part No.: 75601-14</p>	<p>Current Rev. C</p>

Revision Control Record

Rev.	Description of Change	ECN No.	Date
A	NEW RELEASE	07476	12/04/07
B	PROGRAM SOFTWARE	08085	01/31/08
C	BOM CHANGE	09587	01/13/10

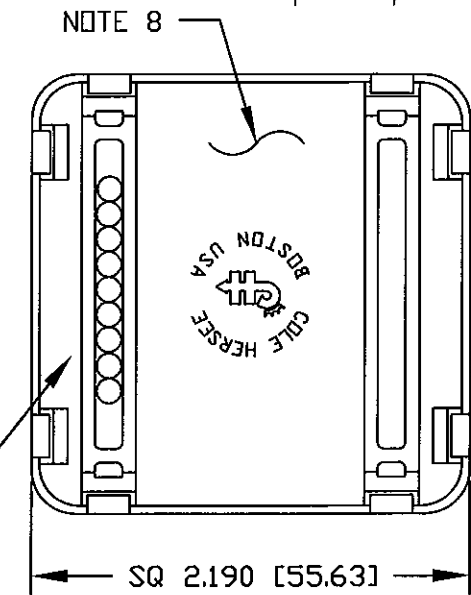
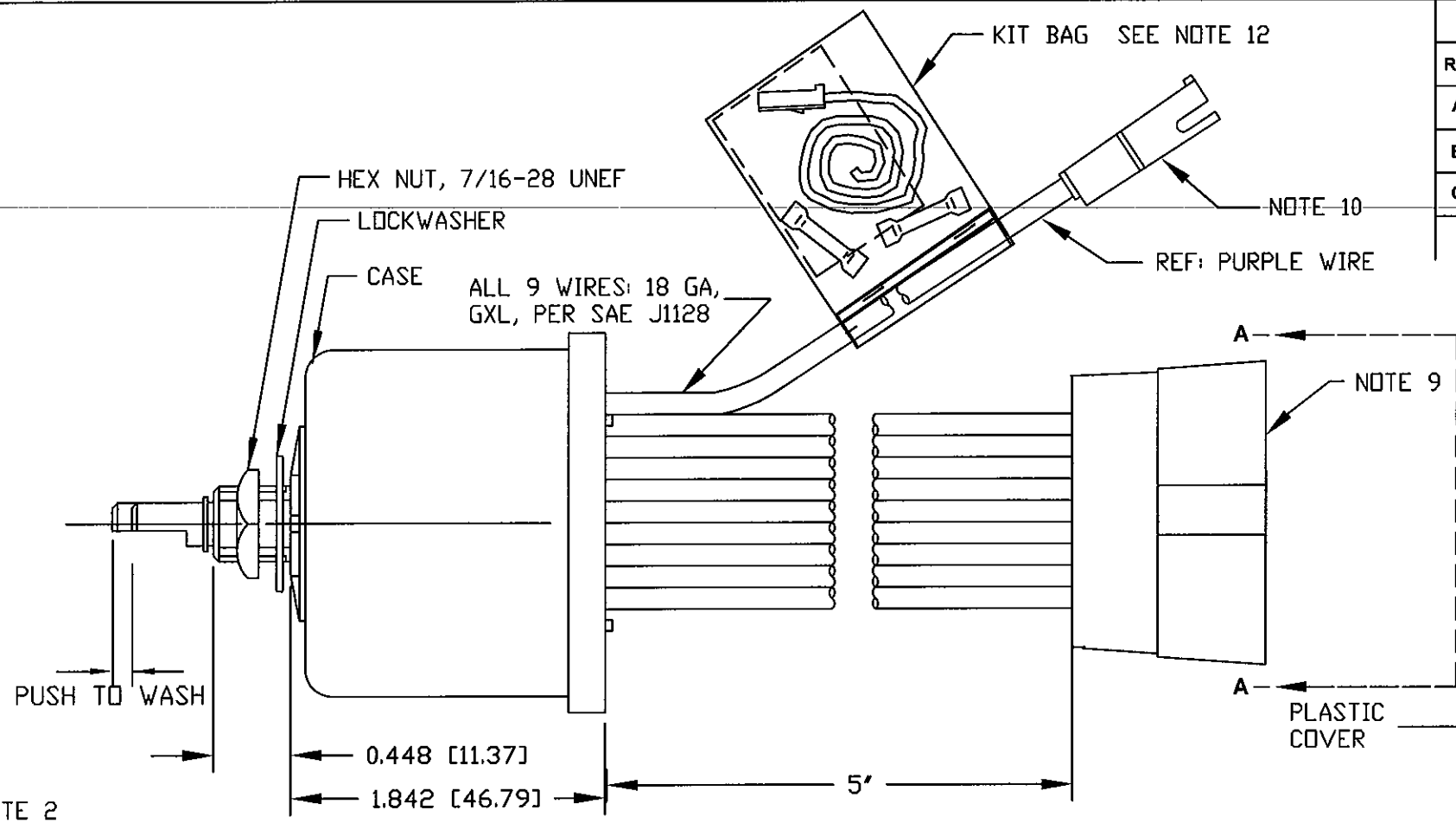
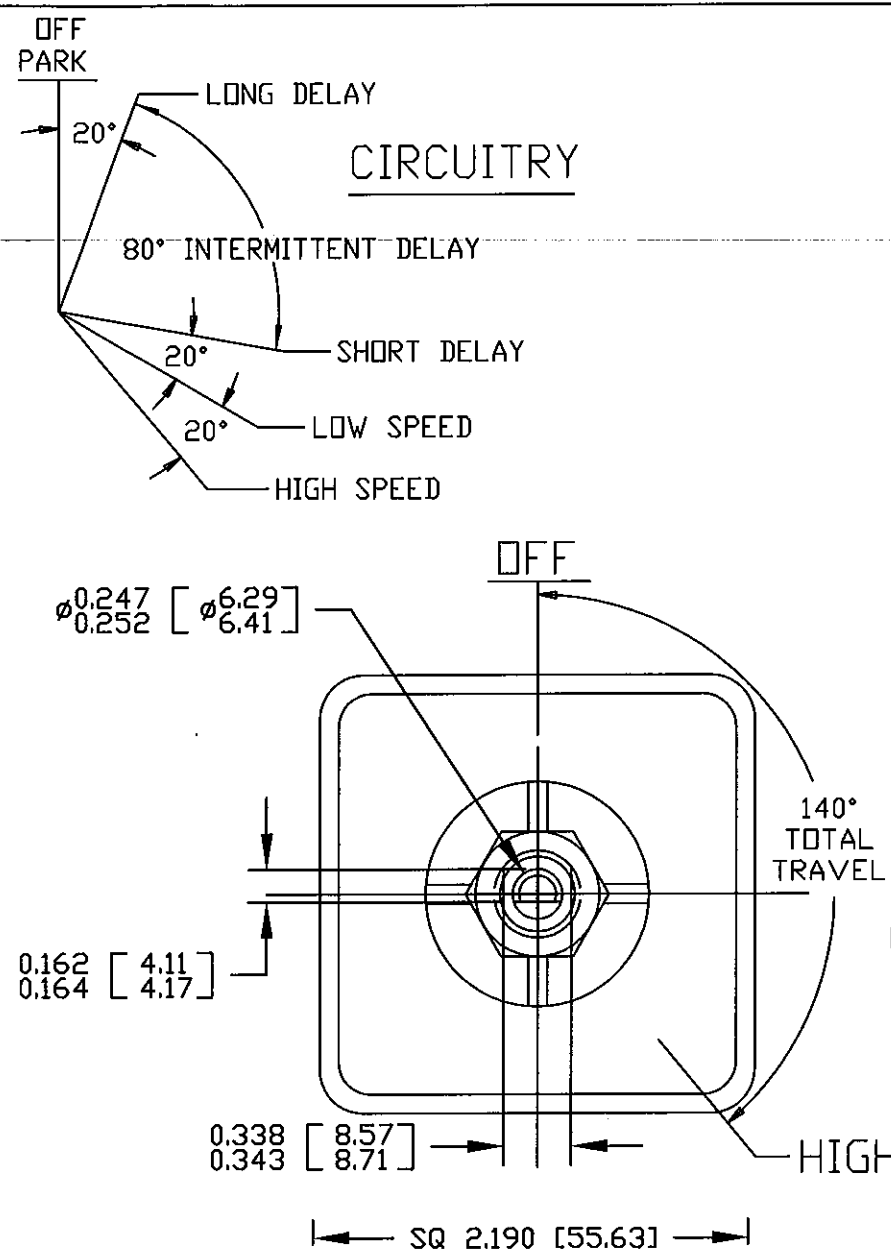

- NOTES:**
- DESIGNED FOR 12V SYSTEM, DUAL MOTOR. MUST BE USED WITH NON-DYNAMIC PARK MOTORS ONLY.
 - PUSH TO WASH FUNCTION RESULTS IN 3 WIPES AFTER RELEASE OF PUSH SWITCH.
 - RATING: VOLTAGE OPERATING RANGE 9VDC TO 16VDC
 ROTARY SWITCH ACTUATION 20,000 CYCLES MINIMUM.
 MOTOR DRIVE: 10 AMPS PER MOTOR CONTINUOUS. START-UP/STALL/LOCKED-ROTOR 30 AMPS. SHORT-CIRCUIT PROOF.
 WASHER CIRCUIT 3 AMPS, PUSH SWITCH 20,000 CYCLES MINIMUM.
 - MICROPROCESSOR CONTROLLED, SOLID-STATE RELAY, CURRENT LIMIT SENSE CIRCUIT, REVERSE POLARITY PROTECTED
 - CONFORMS TO SAE J1455:
 4.11 GENERAL HEAVY DUTY TRUCK ELECTRICAL ENVIRONMENT.
 4.11.1 STEADY-STATE ELECTRICAL CHARACTERISTICS.
 4.11.2 TRANSIENT, NOISE AND ELECTROSTATIC CHARACTERISTICS.
 - INTERMITTENT DELAYS: 1, 2, 4, 7, 11 AND 16 SECONDS
 - ALL DIMENSIONS ARE REFERENCE ONLY UNLESS NOTED OTHERWISE.
 - COLE HERSEE PART NUMBER, REVISION, & DATE CODE STAMPED IN WHITE ON REAR PLASTIC COVER.
 - CONNECTOR, DELPHI: 8-PIN, PART# 2965972 (QTY 1)
 TERMINALS, DELPHI: 2965439 (QTY 8)
 - CONNECTOR, DELPHI: 1-PIN, PART# 8905650 (QTY 1)
 TERMINALS, DELPHI: 2965439 (QTY 1)
 - UNIT REQUIRES TWO SEPARATE WIRE CONNECTIONS TO MOTOR PARK SIGNALS.
 THIS MAY REQUIRE RE-WIRING VEHICLE HARNESS. DO NOT CONNECT PARK WIRES TOGETHER.
 NOTE THAT 1-PIN CONNECTOR (PURPLE WIRE) IS FOR PARK MOTOR #2.
 - WRAP PLASTIC BAG AROUND SWITCH PURPLE WIRE, FOLD AND STAPLE AS SHOWN.

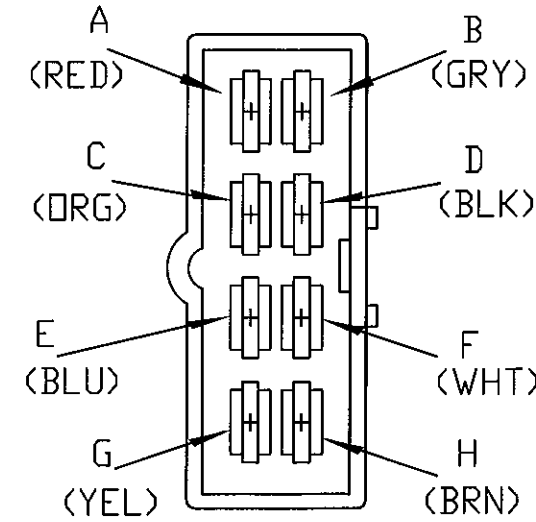

VIEW A-A

COLOR	FUNCTION	CONNECTOR	TERMINAL
RED	VBB (12V POWER)	8-PIN	A
GREY	HIGH-SPEED MOTOR #2	8-PIN	B
ORANGE	LOW-SPEED MOTOR #2	8-PIN	C
BLACK	GROUND (0V)	8-PIN	D
BLUE	PARK MOTOR #1 (SEE NOTE 11)	8-PIN	E
WHITE	HIGH-SPEED MOTOR#1	8-PIN	F
YELLOW	LOW-SPEED MOTOR #1	8-PIN	G
BROWN	WASHER	8-PIN	H
PURPLE	PARK MOTOR #2 (SEE NOTE 11)	1-PIN	

Tolerances Unless otherwise specifically noted, the following are default tolerances:
 * 2-place Decimal Dimensions $\pm .02$ "
 * 3-place Decimal Dimensions $\pm .005$ "
 * Angular Dimensions ± 1.0 Deg.
 * Metric: Refer to equivalent English Dimension Tolerance
 >>> NOTE: All tolerances are Non-Cumulative. <<<

Dimensional Units All dimensions are expressed in inches except those shown in brackets (xxx) are expressed in millimeters

"REF." or an Asterisk (*) = Non-Toleranced Reference Dimension, shown for clarification purposes only.

Used On **EX28333** Scale: **1:1**

PROPRIETARY INFORMATION This Engineering Drawing, and the information contained herein, is proprietary to Cole Hersee Company and may not be disclosed, re-produced, or in any other way transferred or communicated to any other party without the express written consent of an authorized representative of Cole Hersee Company.

DESIGN CONTROL It is the responsibility of the individual using / referencing this drawing to assure that the noted design revision level agrees with the revision level of the Controlled Document (Master Drawing). This is a NON-CONTROLLED DOCUMENT unless otherwise specifically noted.

DO NOT SCALE - Dimensional variation may occur during printing / reproduction.

Drawn By: **JCS** Date Drawn: **12/04/07**

Special Characteristics:

- CC Critical Characteristic, relating to Safety and/or Regulatory Compliance
- X Significant Characteristic relating to Process Control (SPC)
- KC Control Dimension relating to Form - Fit - Function as defined by Cole Hersee Company and/or the Customer

(Note that the Identification of any Characteristics as being "Special" does not alter the requirement that ALL specified dimensions & tolerances must be met.)

Responsible Engineer: **JCS** Pg. **1**

Cole Hersee Co.
 20 Old Colony Ave., South Boston, MA, 02127
 Phn: 617-268-2100 Web: www.colehersee.com

Description:
WINDSHIELD WIPER CONTROLLER, DUAL-MOTOR, 12V, SSR, NON-DYNAMIC PARK MOTOR

Drawing / Part No.: **75601-15** Current Rev. **C**

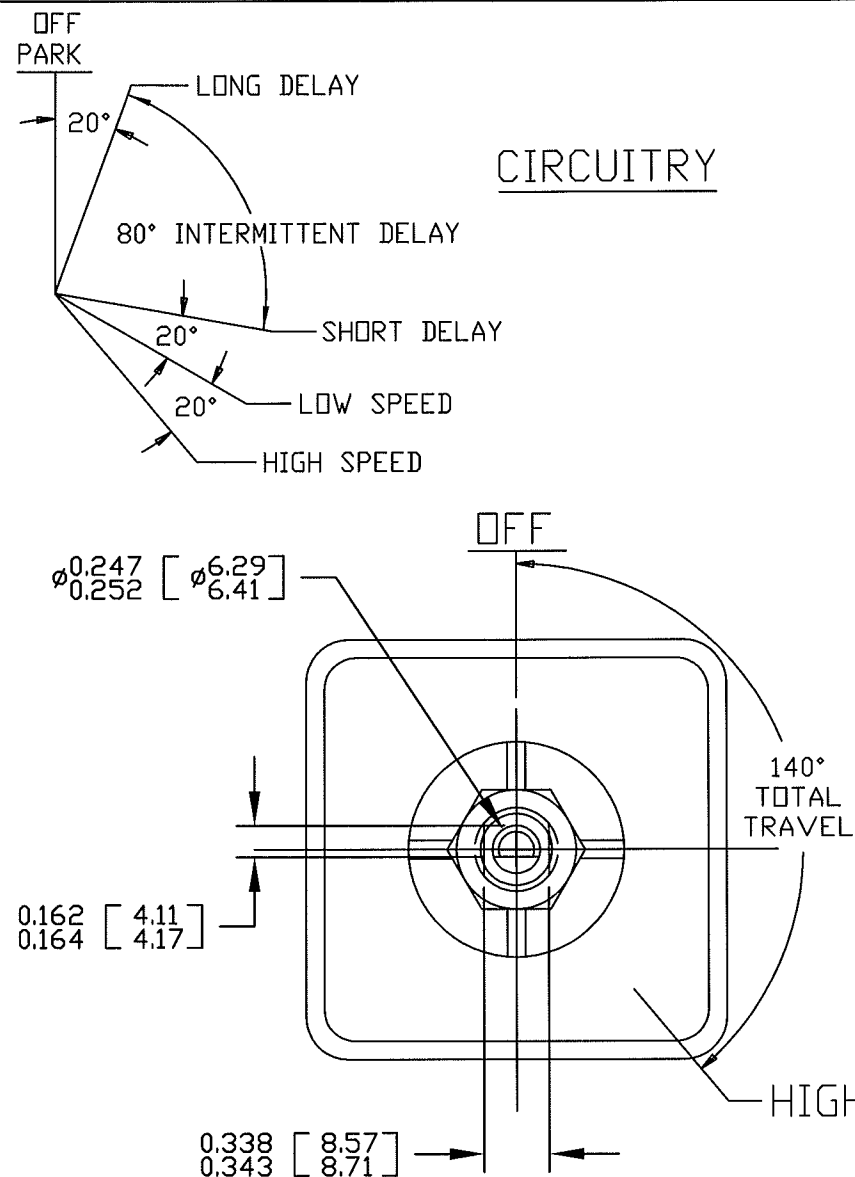

Revision Control Record			
Rev.	Description of Change	ECN No.	Date
H	BOM CHANGE	09588	01/18/10
J	CHANGE NOTE 3	13055	02/07/13

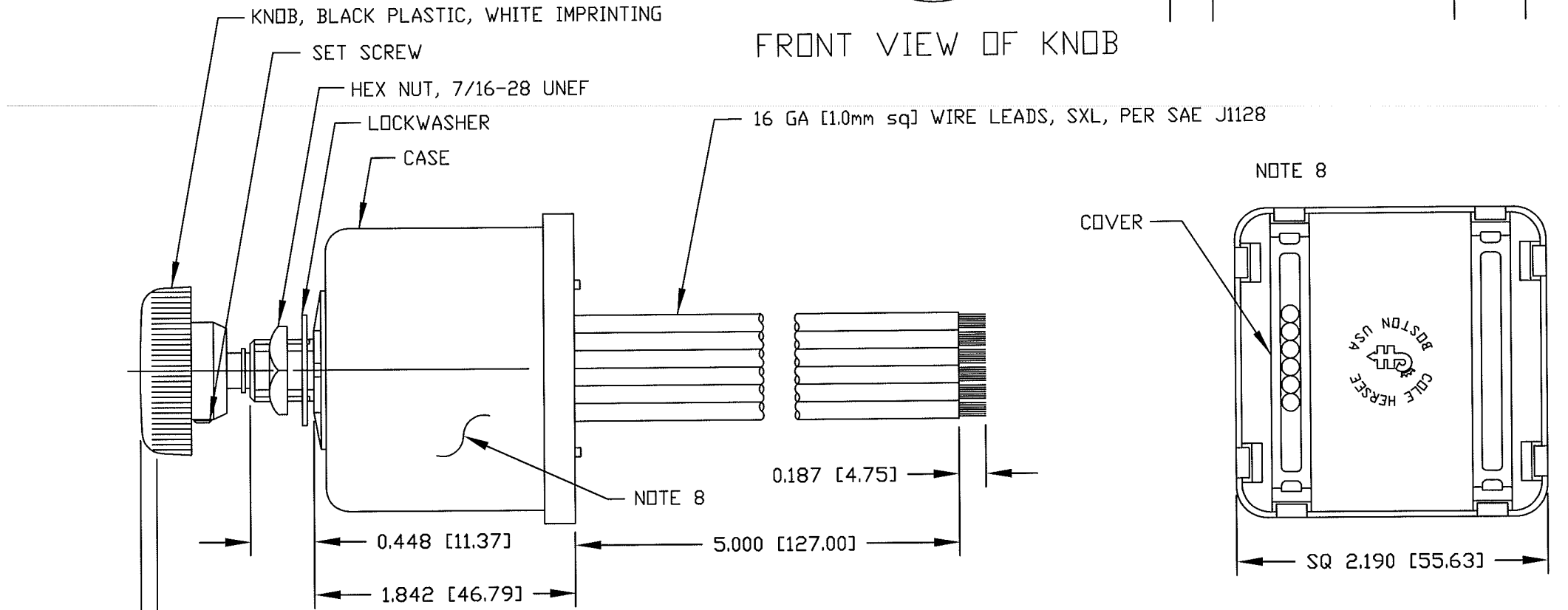

- NOTES:**
- DESIGNED FOR 24V SYSTEM, SINGLE MOTOR, DYNAMIC AND NON-DYNAMIC PARK. TO BE USED WITH PERMANENT MAGNET MOTOR, NEGATIVE GROUND ONLY.
 - PUSH TO WASH FUNCTION: RESULTS IN 2 TO 3 WIPES AFTER RELEASE OF PUSH SWITCH.
 - RATING: VOLTAGE OPERATING RANGE 18VDC TO 32VDC
ROTARY SWITCH ACTUATION 20,000 CYCLES MINIMUM.
MOTOR DRIVE: 15 AMPS CONTINUOUS, START-UP/STALL/LOCKED-ROTOR 50 AMPS. SHORT-CIRCUIT PROTECTED.
WASHER CIRCUIT 3 AMPS, PUSH SWITCH 20,000 CYCLES MINIMUM.
 - MICROPROCESSOR CONTROLLED, SOLID-STATE RELAY, CURRENT LIMIT SENSE CIRCUIT, REVERSE POLARITY PROTECTED
 - CONFORMS TO SAE J1455:
4.11 GENERAL HEAVY DUTY TRUCK ELECTRICAL ENVIRONMENT.
4.11.1 STEADY-STATE ELECTRICAL CHARACTERISTICS.
4.11.2 TRANSIENT, NOISE AND ELECTROSTATIC CHARACTERISTICS.
 - ENVIRONMENTAL EXTREMES BY LOCATION.
5.2 INTERIOR-FORWARD.
 - ALL STEEL PARTS PLATED.
 - ALL DIMENSIONS ARE REFERENCE ONLY UNLESS NOTED OTHERWISE.
 - COLE HERSEE PART NUMBER, REVISION, & DATE CODE MARKED AT RANDOM ON CASE.

COLOR	CONNECT WIRE TO:
YELLOW	MOTOR LOW SPEED TERMINAL
WHITE	MOTOR HIGH SPEED TERMINAL
BLUE	MOTOR PARK TERMINAL
BLACK	GROUND (B-) THIS CONNECTION MUST BE MADE
BROWN	WASHER PUMP (B+ TERMINAL)
RED	B+

SEPARATE B+ AND GROUND CONNECTIONS MUST BE MADE TO THE WIPER MOTOR

Tolerances Unless otherwise specifically noted, the following are default tolerances: * 2-place Decimal Dimensions +/- .02" * 3-place Decimal Dimensions +/- .005" * Angular Dimensions +/- 1.0 Deg. * Metric: Refer to equivalent English Dimension Tolerance >>> NOTE: All tolerances are Non-Cumulative. <<<		PROPRIETARY INFORMATION This Engineering Drawing, and the information contained herein, is proprietary to Cole Hersee Company and may not be disclosed, re-produced, or in any other way transferred or communicated to any other party without the express written consent of an authorized representative of Cole Hersee Company.		Special Characteristics: <input checked="" type="checkbox"/> Critical Characteristic, relating to Safety and/or Regulatory Compliance <input checked="" type="checkbox"/> Significant Characteristic relating to Process Control (SPC) <input checked="" type="checkbox"/> Control Dimension relating to Form - Fit - Function as defined by Cole Hersee Company and/or the Customer (Note that the identification of any Characteristics as being "Special" does not alter the requirement that ALL specified dimensions & tolerances must be met.)	
Dimensional Units All dimensions are expressed in inches except those shown in brackets (xxx) are expressed in millimeters "REF." or an Asterisk (*) = Non-Toleranced Reference Dimension, shown for clarification purposes only.		DESIGN CONTROL It is the responsibility of the individual using / referencing this drawing to assure that the noted design revision level agrees with the revision level of the Controlled Document (Master Drawing). This is a NON-CONTROLLED DOCUMENT unless otherwise specifically noted.		DO NOT SCALE - Dimensional variation may occur during printing / reproduction.	
Used On or Ref.: EX-26548	Scale: 1:1	Drawn By: ZU	Date Drawn: 03/13/87	Responsible Engineer:	Pg. 1
Cole Hersee Co. 20 Old Colony Ave., South Boston, MA, 02127 Phn: 617-268-2100 Web: www.colehersee.com				Description: WINDSHIELD WIPER & WASHER SW. INTERMITTENT DELAY, 24V.D.C.	
Drawing / Part No.: 75602-04				Current Rev.: J	