

SP2504N Series 2.5V 20A Diode Array

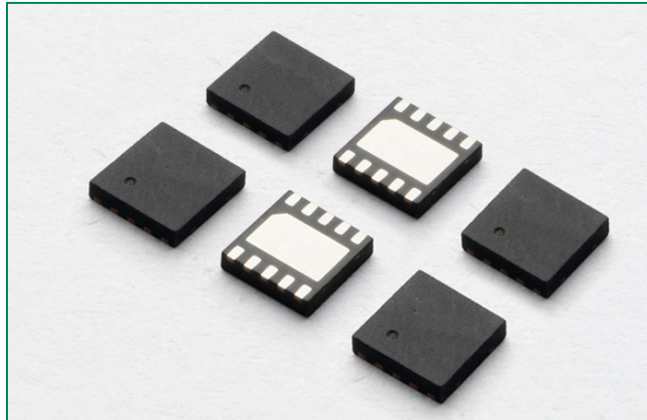

Pinout

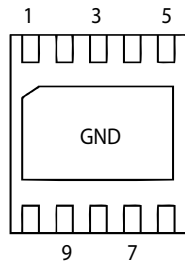

Functional Block Diagram

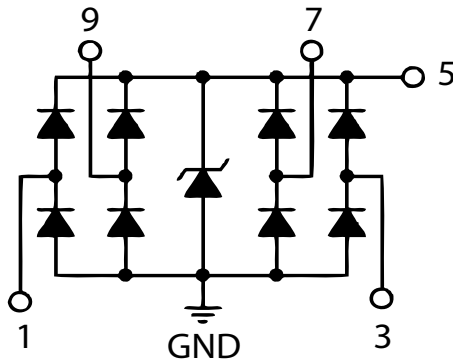

Additional Information



Resources

Samples

Description

The SP2504N integrates 4 channels of low capacitance diodes with an additional zener diode to protect sensitive I/O pins against lightning induced surge events and ESD. This robust device can safely absorb up to 20A per IEC 61000-4-5, 2nd edition ($t_p=8/20\mu s$) without performance degradation and a minimum $\pm 30kV$ ESD per IEC 61000-4-2 international standard. The low loading capacitance makes the SP2504N ideal for protecting high-speed signal pins.

Features

- ESD, IEC 61000-4-2, $\pm 30kV$ contact, $\pm 30kV$ air
- EFT, IEC 61000-4-4, 40A ($t_p=5/50ns$)
- Lightning, IEC 61000-4-5, 2nd edition 20A ($t_p=8/20\mu s$)
- Low capacitance of 3.5pF (TYP) per I/O
- Low leakage current of 1 μA (MAX) at 2.5V
- RoHS compliant and lead-free

Applications

- 10/100/1000 Ethernet Interfaces
- Customer Premise Equipment (CPE)
- VoIP Phones
- Set Top Boxes
- PBX Systems
- Surveillance Cameras

Application Example

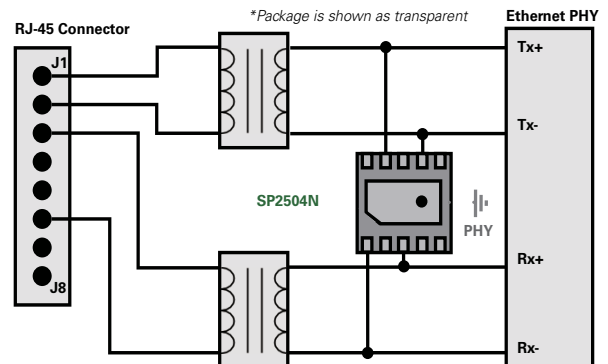

Life Support Note:

Not Intended for Use in Life Support or Life Saving Applications

The products shown herein are not designed for use in life sustaining or life saving applications unless otherwise expressly indicated.

Absolute Maximum Ratings

Symbol	Parameter	Value	Units
I_{PP}	Peak Current ($t_p=8/20\mu s$)	20.0	A
P_{PK}	Peak Pulse Power ($t_p=8/20\mu s$)	300	W
T_{OP}	Operating Temperature	-40 to 125	°C
T_{STOR}	Storage Temperature	-55 to 150	°C

CAUTION: Stresses above those listed in "Absolute Maximum Ratings" may cause permanent damage to the device. This is a stress only rating and operation of the device at these or any other conditions above those indicated in the operational sections of this specification is not implied.

Thermal Information

Parameter	Rating	Units
Storage Temperature Range	-55 to 150	°C
Maximum Junction Temperature	150	°C
Maximum Lead Temperature (Soldering 20-40s)	260	°C

Electrical Characteristics ($T_{OP}=25^\circ C$)

Parameter	Symbol	Test Conditions	Min	Typ	Max	Units
Reverse Standoff Voltage	V_{RWM}				2.5	V
Snap Back Voltage	V_{SB}	$I_{SB}=50mA$	2.0			V
Reverse Leakage Current	I_{LEAK}	$V_R=2.5V$, I/O to GND		0.5	1.0	μA
Clamp Voltage ¹	V_C	$I_{PP}=1A$, $t_p=8/20\mu s$, Fwd			5.0	V
		$I_{PP}=5A$, $t_p=8/20\mu s$, Fwd			6.3	V
		$I_{PP}=10A$, $t_p=8/20\mu s$, Fwd			8.0	V
		$I_{PP}=20A$, $t_p=8/20\mu s$, Fwd			11.5	V
Dynamic Resistance	R_{DYN}	$(V_{C2}-V_{C1})/(I_{PP2}-I_{PP1})$		0.35		\square
ESD Withstand Voltage ¹	V_{ESD}	IEC61000-4-2 (Contact)	± 30			kV
		IEC61000-4-2 (Air)	± 30			kV
Diode Capacitance ¹	$C_{I/O-GND}$	Reverse Bias=0V		3.5	5.0	pF
Diode Capacitance ¹	$C_{I/O-I/O}$	Reverse Bias=0V		2.0		pF

Note: ¹ Parameter is guaranteed by design and/or device characterization.

Pulse Waveform

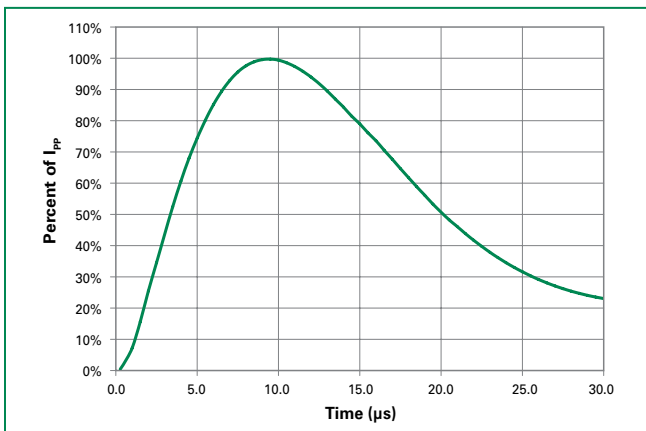

Clamping Voltage vs. I_{PP}

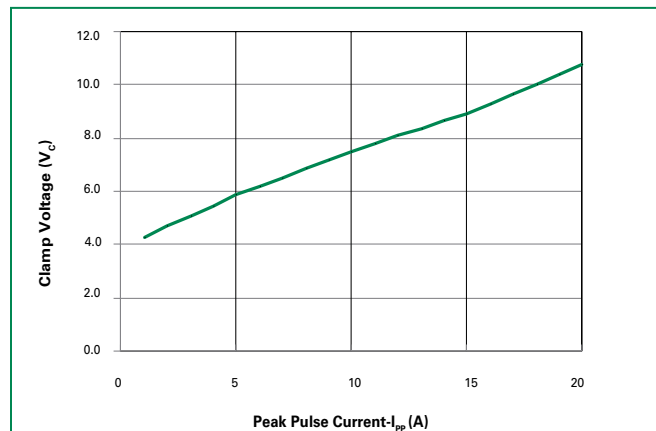

Capacitance vs. Bias

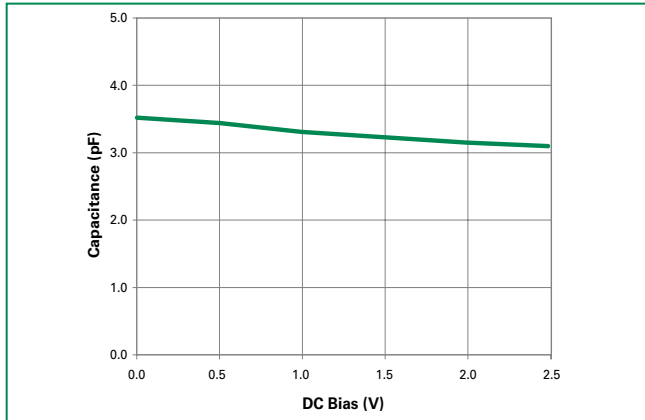

Ordering Information

Part Number	Package	Marking	Min. Order Qty.
SP2504NUTG	μDFN-10	TH4	3000

Soldering Parameters

Reflow Condition	Pb – Free assembly	
Pre Heat	- Temperature Min ($T_{s(min)}$)	150°C
	- Temperature Max ($T_{s(max)}$)	200°C
	- Time (min to max) (t_s)	60 – 180 secs
Average ramp up rate (Liquidus) Temp (T_L) to peak	3°C/second max	
$T_{s(max)}$ to T_L - Ramp-up Rate	3°C/second max	
Reflow	- Temperature (T_L) (Liquidus)	217°C
	- Temperature (t_L)	60 – 150 seconds
Peak Temperature (T_p)	260 ^{+0/-5} °C	
Time within 5°C of actual peak Temperature (t_p)	20 – 40 seconds	
Ramp-down Rate	6°C/second max	
Time 25°C to peak Temperature (T_p)	8 minutes Max.	
Do not exceed	260°C	

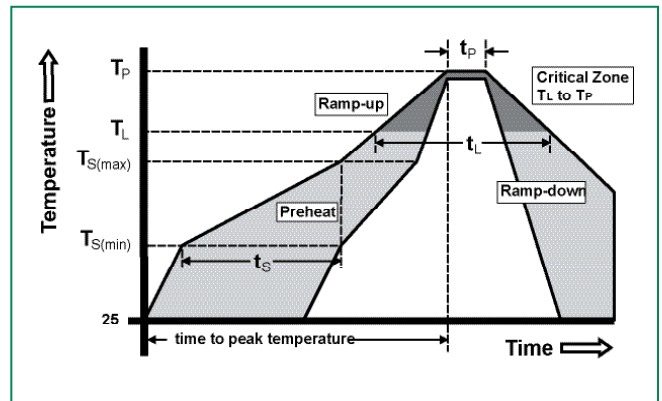

Product Characteristics

Lead Plating	Pre-Plated Frame
Lead Material	Copper Alloy
Lead Coplanarity	0.0004 inches (0.102mm)
Substitute Material	Silicon
Body Material	Molded Epoxy
Flammability	UL 94 V-0

Notes :

1. All dimensions are in millimeters
2. Dimensions include solder plating.
3. Dimensions are exclusive of mold flash & metal burr.
4. . Blo is facing up for mold and facing down for trim/form, i.e. reverse trim/form.
5. Package surface matte finish VDI 11-13.

Part Numbering System

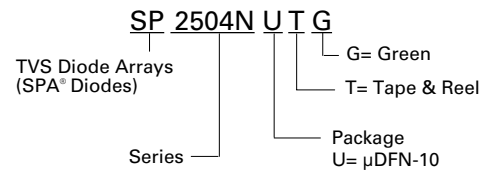

Part Marking System

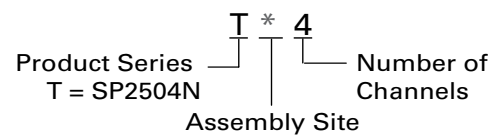

Package Dimensions — μ DFN-10

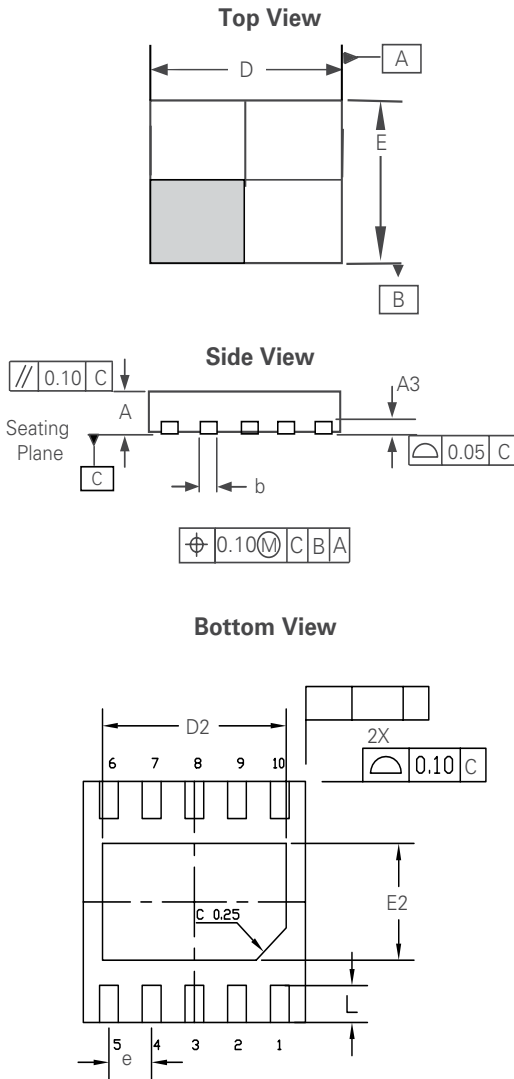

Package	μ DFN-10 (2.6x2.6mm)					
JEDEC	MO-229					
Symbol	Millimeters			Inches		
	Min	Nom	Max	Min	Nom	Max
A	0.45	0.50	0.55	0.018	0.020	0.022
A3	0.130 Ref			0.005 Ref		
b	0.17	0.22	0.27	0.006	0.008	0.010
D	2.50	2.60	2.70	0.097	0.101	0.105
D2	2.10	2.15	2.20	0.081	0.083	0.085
E	2.50	2.60	2.70	0.097	0.101	0.105
E2	1.21	1.26	1.31	0.046	0.049	0.051
e	0.50 BSC			0.020 BSC		
L	0.35	0.40	0.45	0.014	0.016	0.018

Recommended Solder Pads μ DFN-10L 2.6x2.6mm

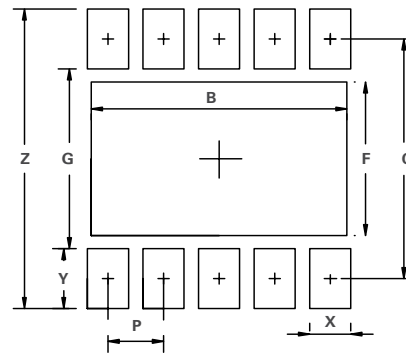

Dimension		
Symbol	Millimeters	Inches
B	2.30	0.091
C	2.20	0.087
F	1.41	0.056
G	1.65	0.065
P	0.50	0.020
X	0.37	0.015
Y	0.55	0.022
Z	2.75	0.108

Embossed Carrier Tape & Reel Specification — μ DFN-10 (2.6x2.6mm)

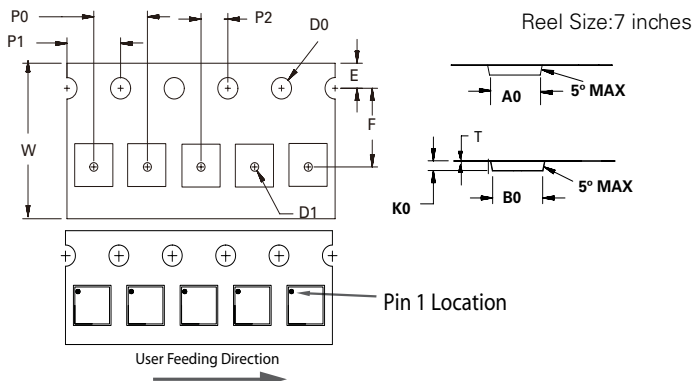

Symbol	Millimeters
A0	2.82 ± 0.05
B0	2.82 ± 0.05
D0	∅1.50 + 0.10
D1	∅0.50 + 0.05
E	1.75 ± 0.10
F	3.50 ± 0.05
K0	0.76 ± 0.05
P0	4.00 ± 0.10
P1	4.00 ± 0.10
P2	2.00 ± 0.05
T	0.25 ± 0.02
W	8.00 + 0.30 / - 0.10

Disclaimer Notice - Information furnished is believed to be accurate and reliable. However, users should independently evaluate the suitability of and test each product selected for their own applications. Littelfuse products are not designed for, and may not be used in, all applications. Read complete Disclaimer Notice at www.littelfuse.com/disclaimer-electronics.