

# SE-330HV MANUAL

## NEUTRAL-GROUNDING-RESISTOR MONITOR

REVISION 5-M-101817

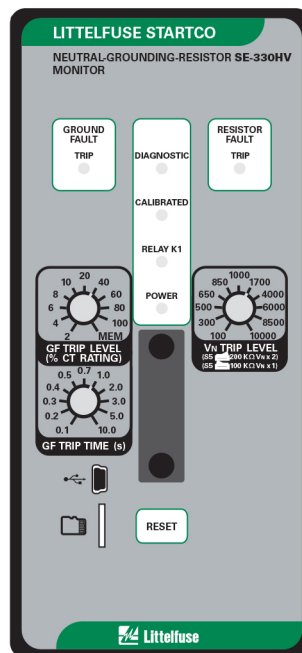

Copyright © 2017 Littelfuse Startco.

All rights reserved.

This page intentionally left blank.

## TABLE OF CONTENTS

SECTION	PAGE
<b>1 General</b> .....	1
1.1 Modern Resistance-Grounded Systems .....	1
1.2 SE-330HV NGR Monitoring .....	1
<b>2 Operation</b> .....	3
2.1 Settings .....	3
2.1.1 GF Trip Time .....	3
2.1.2 GF Trip Level .....	3
2.1.3 $V_N$ Trip Level .....	3
2.1.4 Configuration Settings .....	3
2.1.4.1 Trip-Relay Mode and Trip-Memory Mode (S2) .....	3
2.1.4.2 Ground-Fault-Trip Latch (S3) .....	3
2.1.4.3 Resistor-Fault-Trip Latch (S4) .....	3
2.1.4.4 Sensing-Resistor Selection (S5) .....	3
2.1.4.5 Frequency (S6) .....	4
2.1.4.6 Upgrade Mode (S8) .....	4
2.1.5 Resistor-Fault Trip Time .....	4
2.1.6 Resistor-Fault Trip Level .....	4
2.1.7 Geo-Magnetic Filter .....	4
2.2 Calibration .....	4
2.3 Trip Indication and Reset .....	4
2.4 Remote Operation .....	4
2.5 Relay K1 LED .....	5
2.6 Unit Healthy Output .....	5
2.7 Diagnostic LED .....	5
2.8 Analog Output .....	5
<b>3 Installation</b> .....	6
3.1 SE-330HV .....	6
3.2 Sensing Resistor .....	6
3.3 Ground-Fault CT .....	18
3.4 Isolated Ground Connection .....	23
<b>4 Data Interfaces</b> .....	24
4.1 SD Card .....	24
4.1.1 Datalogging .....	24
4.1.2 Firmware Upgrade .....	24
4.2 USB Interface .....	24
4.3 Network Communications .....	24
<b>5 Troubleshooting</b> .....	25
<b>6 Technical Specifications</b> .....	27
6.1 SE-330HV .....	27
6.2 Sensing Resistors .....	29
6.3 Current Sensors .....	30
<b>7 Ordering Information</b> .....	31
<b>8 Warranty</b> .....	32
<b>9 Test Procedures</b> .....	32
9.1 Resistor-Fault Tests .....	32
9.1.1 Calibration and Open Test .....	32
9.1.2 Voltage Test .....	32
9.2 Sensing-Resistor Test .....	32
9.3 Analog-Output Test .....	32
9.4 Ground-Fault Performance Test .....	33
<b>Appendix A SE-330HV Revision History</b> .....	34

## LIST OF FIGURES

FIGURE	PAGE
1 Configuration Switches .....	3
2 Analog-Output Connections .....	5
3 SE-330HV Connection Diagram .....	7
4 SE-330HV Outline and Panel-Mounting Details .....	8
5 SE-330HV Outline and Surface-Mounting Details .....	9
6 SE-IP65CVR-G Weatherproof Cover Outline .....	10
7 SE-IP65CVR-G Weatherproof Cover Installation .....	11
8 ER-15KV Sensing Resistor .....	12
9 ER-25KV Sensing Resistor .....	13
10 ER-35KV Sensing Resistor .....	14
11 ER-72KV Sensing Resistor Outline .....	15
12 ER-72KV Sensing Resistor Mounting Details .....	16
13 ER-1000HV Sensing Resistor .....	17
14 ER-1000HV Simplified Connection Diagram .....	18
15 EFCT-1 Ground-Fault Current Sensor .....	19
16 SE-CS30-70 Ground-Fault Current Sensor .....	20
17 EFCT-26 and SE-CS30-26 Ground-Fault Current Sensors .....	21
18 RK-332 Remote Indication and Reset .....	22
19 PGA-0520 Analog Percent Current Meter .....	22
20 Simplified Isolated-Ground Connection .....	23
21 Ground-Fault-Test Circuit .....	33

## LIST OF TABLES

TABLE	PAGE
1 Typical Values for Tripping Systems .....	2
2 Ground-Fault Trip Levels for Selected CT's .....	2
3 Ground-Fault-Test Record .....	33

## DISCLAIMER

Specifications are subject to change without notice. Littelfuse Startco is not liable for contingent or consequential damages, or for expenses sustained as a result of incorrect application, incorrect adjustment, or a malfunction.

This page intentionally left blank.

## 1. GENERAL

### 1.1 MODERN RESISTANCE-GROUNDED SYSTEMS

A high-resistance-grounded system uses a neutral-grounding resistor (NGR) with a low let-through current to limit ground-fault current. This is an improvement over low-resistance or solidly-grounded systems because, in those systems, a ground-fault flash hazard exists and a ground fault can result in substantial point-of-fault damage. High-resistance grounding eliminates these problems and modern ground-fault protection operates reliably at low current levels. Furthermore, the probability of an arc-flash incident is significantly reduced in a high-resistance-grounded system.

NGR selection depends on system charging current and whether the system is an alarm-only or a tripping system. Alarm-only systems are usually restricted to system voltages up to 5 kV with NGR let-through currents of 5 A or less. Occasionally, alarm-only systems up to 15 kV and up to 10 A are used; however, they are not common because a ground fault on such a system tends to escalate to a phase-to-phase fault before the ground fault can be located and cleared. Consult CEC 10-1102, NEC 250.36, and NEC 250.186 for application details.

System charging current is the capacitive current that flows to ground when a bolted ground fault occurs. This current can be calculated or measured. For small systems, the magnitude of charging current can be conservatively estimated as  $\frac{1}{2}$  A per 1,000 kVA on low-voltage systems and 1 A per 1,000 kVA on medium-voltage systems.

In an alarm-only system or in a tripping system without selective coordination, choose an NGR with a let-through current larger than the system charging current and set the pick-up current of ground-fault devices at or below 50% of the NGR let-through current.

In a tripping system with selective coordination, use ground-fault devices with a definite-time characteristic to achieve time coordination. Use the same pick-up current for all ground-fault devices—this value must be larger than the charging current of the largest feeder. Select an NGR with a let-through current between five and 10 times the pick-up current of the ground-fault devices.

Do not use a grounding transformer with a low-voltage resistor:

- The combined cost of a transformer and a low-voltage resistor is more than the cost of a resistor rated for line-to-neutral voltage.
- A transformer saturated by a ground fault through a rectifier can make ground-fault protection inoperative.
- Transformer inrush current up to 12 times rated current can cause a ground-fault voltage larger than expected.
- A parallel transformer winding makes it difficult to monitor NGR continuity.

- A transformer can provide the inductance necessary to cause ferroresonance if the NGR opens.

Following these guidelines will reduce the flash hazard, reduce point-of-fault damage, achieve reliable ground-fault protection, and ensure a stable system not subject to ferroresonance.

### 1.2 SE-330HV NGR MONITORING

The SE-330HV is a microprocessor-based neutral-grounding-resistor monitor that detects NGR failures and ground faults in resistance-grounded systems. The SE-330HV measures NGR resistance, NGR current, and transformer or generator neutral-to-ground voltage. The components required to monitor an NGR are an SE-330HV, a 100- or 200-k $\Omega$  ER-series sensing resistor, and a current transformer (CT).

Power-circuit elements, other than neutral-connected NGR's, that purposefully connect the power system to ground are often not compatible with SE-330HV NGR monitoring. These elements include single-phase grounding transformers, grounded-wye-primary potential transformers (PT's), and grounded-wye-primary power transformers.

The SE-330HV continuously measures NGR resistance in an unfaulted system. It will trip on resistor fault if NGR resistance varies from its calibrated value. When a ground fault occurs, voltage is present on the neutral and NGR current will flow if the NGR is healthy. The SE-330HV will trip on ground fault if fault current exceeds the GF TRIP LEVEL setting for an interval equal to the GF TRIP TIME setting. However, if the NGR fails open during a ground fault, it is possible for fault resistance to satisfy the NGR resistance measurement. To detect this double-fault condition, the SE-330HV measures neutral voltage. If neutral voltage exceeds the  $V_N$  TRIP LEVEL setting, and if NGR current is less than 5% of the current transformer (CT) rating, the SE-330HV will trip on resistor fault. If the resistor-fault circuit is tripped and the neutral voltage exceeds the  $V_N$  TRIP LEVEL setting for an interval greater than the GF TRIP TIME setting, the ground-fault circuit will also trip.

Ground-fault current is sensed by a CT with a 1- or 5-A secondary, or by a CT (EFCT-x or SE-CS30-x) with a 50-mA secondary. The trip level of the ground-fault circuit is adjustable from 2 to 100% of the CT rating and trip time is adjustable from 0.1 to 10.0 seconds.

The SE-330HV has four output relays. Relay K1 is the trip relay. Relays K2 and K3 provide ground-fault and resistor-fault indication. K4 is a solid-state relay that provides UNIT HEALTHY indication. Relay K1 will operate on either a resistor fault or a ground fault, and it can be set to operate in the fail-safe or non-fail-safe mode for undervoltage or shunt-trip applications.

Additional features include LED trip indication, trip memory, front-panel and remote reset, 4-20-mA analog output, trip event recorder, USB local communications, microSD™ data logging, and optional network communications.

The SE-330HV provides the following additional features:

- When the trip level is set to MEM, the ground-fault trip setting is defined by an internal non-volatile memory variable. Range is 2 to 100% in 1% increments of the CT-primary rating.
- Indication relays can be set to fail-safe or non-fail-safe.
- The number of trip records has been increased to 100 and includes date and time stamping.
- A microSD™ card interface can be used for long-term data logging and firmware updates. A microSD™ card and a microSD-to-SD adapter is included. See Section 4.1.
- For ease of connection to new devices, the RS-232 interface has been replaced by a Mini B USB port.
- Dual Ethernet ports are available with support for fiber-optic and RJ45 interfaces.
- The IEC 61850 protocol has been added.

TABLE 1. TYPICAL VALUES FOR TRIPPING SYSTEMS

SYSTEM VOLTAGE (LINE-LINE) (VOLTS)	NEUTRAL-GROUNDING RESISTOR		SENSING RESISTOR		GROUND-FAULT TRIP LEVEL (AMPERES)	V <sub>N</sub> TRIP LEVEL (VOLTS)
	CURRENT (AMPERES)	RESISTANCE (OHMS)	MODEL	RESISTANCE (SWITCH S5 SETTING)		
7,200	15	277	ER-15KV	100 kΩ	3.0	850
14,400	15	554	ER-15KV	100 kΩ	3.0	1,700
7,200	25	166	ER-15KV	100 kΩ	5.0	850
14,400	25	332	ER-15KV	100 kΩ	5.0	1,700
25,000	25	577	ER-25KV	100 kΩ	5.0	4,000
35,000	25	808	ER-35KV	100 kΩ	5.0	6,000
72,000	100	420	ER-72KV	200 kΩ	20.0	6,000 x 2 = 12,000

TABLE 2. GROUND-FAULT TRIP LEVELS FOR SELECTED CT'S

GF TRIP LEVEL <sup>(1)</sup> (%)	EFCT-X 5:0.05 (AMPERES)	SE-CS30-X 30:0.05 (AMPERES)	50:1 50:5 (AMPERES)	100:1 100:5 (AMPERES)	200:1 200:5 (AMPERES)	400:1 400:5 (AMPERES)
2	0.10	0.60	*	*	*	*
4	0.20	1.20	*	*	*	16
6	0.30	1.80	*	*	12	24
8	0.40	2.40	*	8	16	36
10	0.50	3.00	5	10	20	40
20	1.00	6.00	10	20	40	80
40	2.00	12.0	20	40	80	160
60	3.00	18.0	30	60	120	240
80	4.00	24.0	40	80	160	320
100	5.00	30.0	50	100	200	400

<sup>(1)</sup> When set to MEM, range is 2 to 100% in 1% increments.

\* Setting not recommended.

**2. OPERATION**

**2.1 SETTINGS**

**2.1.1 GF TRIP TIME**

GF TRIP TIME (definite time) is adjustable from 0.1 to 10.0 seconds. Time-coordinated ground-fault protection requires this setting to be longer than the trip times of downstream ground-fault devices.

A trip-time accumulator provides a ground-fault memory function for detection of intermittent faults. The accumulated time increases when a ground fault is detected and decreases when a ground fault is not detected. A trip will eventually occur when the time for fault current above the trip level is greater than the time for fault current below the trip level.

**2.1.2 GF TRIP LEVEL**

The SE-330HV uses a Discrete-Fourier Transform (DFT) Algorithm to measure the fundamental component of NGR current.

Choose an NGR let-through current and a ground-fault trip level according to the guidelines in Section 1.1. Set the ground-fault trip level as a percentage (2 to 100) of the CT-primary rating. When the GF Trip Level is set to MEM, the ground-fault setting stored in non-volatile memory is used. This parameter must be set using a PC running the SE-MON330 software connected to the USB interface. The setting range is 2 to 100% of CT primary rating in 1% increments. The default value is 15%. Inputs are provided for 5-, 1-, and 0.05-A-secondary CT's. Typical values for 15-, 25-, and 100-A tripping systems are shown in Table 1. Ground-fault trip levels for selected CT's are shown in Table 2. Refer to the NGR Monitor Set-Point Assistant at [www.littelfuse.com/relayscontrols](http://www.littelfuse.com/relayscontrols) for other systems. The Set-Point Assistant is included with the SE-MON330 software.

**2.1.3 V<sub>N</sub> TRIP LEVEL**

The SE-330HV uses a DFT algorithm to measure the fundamental component of neutral voltage (V<sub>N</sub>).

If neutral voltage is greater than the V<sub>N</sub> TRIP LEVEL setting for the duration of the resistor-fault trip time and ground-fault current is less than 5% of the CT rating, the SE-330HV will trip on resistor fault. If the resistor-fault circuit is tripped and the neutral voltage exceeds the V<sub>N</sub> TRIP LEVEL setting for an interval greater than the GF TRIP TIME setting, the ground-fault circuit will also trip.

The V<sub>N</sub> TRIP LEVEL range is 100 to 10,000 V with switch S5 in the 100-kΩ (Vx1) position, and the range is 200 to 20,000 V with switch S5 in the 200-kΩ (Vx2) position. Calculate the voltage across the NGR when NGR current is equal to the pick-up current of the ground-fault circuit. Set the V<sub>N</sub> TRIP LEVEL at the next largest value. See Fig. 1 and Section 2.1.4.4.

Typical values for 15-, 25- and 100-A tripping systems are shown in Table 1. Refer to the NGR Monitor Set-Point Assistant at [www.littelfuse.com/relayscontrols](http://www.littelfuse.com/relayscontrols) for other systems.

**NOTE:** A resistor-fault trip is held off if the ground-fault current is above 5% of the CT rating.

**2.1.4 CONFIGURATION SETTINGS**

Eight configuration switches (S1 to S8) and a calibration button are located behind the access cover on the front panel. See Fig. 1.

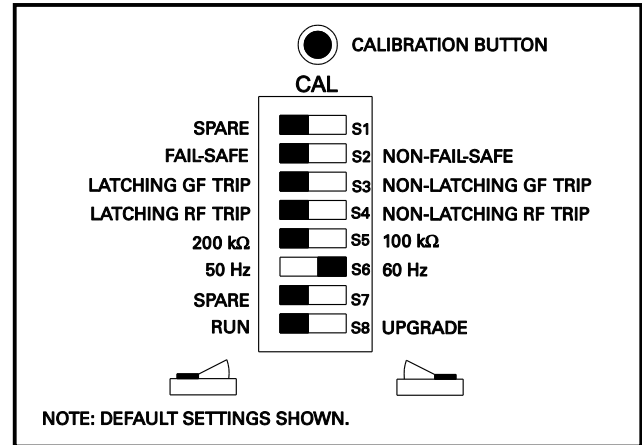

FIGURE 1. Configuration Switches.

**2.1.4.1 TRIP-RELAY MODE AND TRIP-MEMORY MODE (S2)**

Set switch S2 to select the operating mode of trip relay K1. In the non-fail-safe mode, relay K1 energizes and its contact closes when a trip occurs. The non-fail-safe mode can be used to trip shunt-trip circuit breakers. In the non-fail-safe mode, SE-330HV trips are reset when supply voltage is cycled.

In the fail-safe mode, relay K1 energizes and its contact closes if there are no trips. Contacts open if there is a trip, a loss of supply voltage, or a processor failure. In the fail-safe mode, SE-330HV trips are not reset when supply voltage is cycled.

**NOTE:** Switch S2 does not affect the operating modes of relays K2, K3, and K4.

**2.1.4.2 GROUND-FAULT-TRIP LATCH (S3)**

Set switch S3 to select latching or non-latching ground-fault-circuit operation. Non-latching operation defeats ground-fault trip-memory. See Section 2.3.

**2.1.4.3 RESISTOR-FAULT-TRIP LATCH (S4)**

Set switch S4 to select latching or non-latching resistor-fault-circuit operation. Non-latching operation defeats resistor-fault trip-memory. See Section 2.3

**2.1.4.4 SENSING-RESISTOR SELECTION (S5)**

Set switch S5 to the resistance of the sensing resistor. For the ER-15KV, ER-25KV, and ER-35KV, select 100 kΩ. For the ER-1000HV and ER-72KV, select 200 kΩ. Switch S5 sets the resistor-fault trip value and the V<sub>N</sub> TRIP LEVEL range. See Section 2.1.3.

#### 2.1.4.5 FREQUENCY (S6)

Set switch S6 to 50 or 60 Hz to tune the digital filter to the line frequency of the monitored system.

#### 2.1.4.6 UPGRADE MODE (S8)

The microSD™ card is used for firmware upgrades. See Section 4.1.2 for upgrade instructions.

**NOTE:** An upgrade causes an SE-330HV restart and this may cycle the output relays.

#### 2.1.5 RESISTOR-FAULT TRIP TIME

The resistor-fault trip time can be adjusted from 12 (default) to 60 seconds using the SE-MON330 software or via network communications.

#### 2.1.6 RESISTOR-FAULT TRIP LEVEL

The resistor-fault trip level can be adjusted using the SE-MON330 software or via network communications. See Section 6.1.

#### 2.1.7 GEO-MAGNETIC FILTER

A low-frequency ground current can be caused by the Earth's magnetic field and from charged clouds passing overhead during a thunderstorm. In some rare conditions, this can cause a false resistor-fault trip. Enabling the geo-magnetic filter and increasing the resistor-fault trip time can help counteract these effects.

A trip time of 30 seconds is recommended when the geo-magnetic filter is enabled.

The geo-magnetic filter is disabled by default, but can be enabled using the SE-MON330 software or via network communications.

### 2.2 CALIBRATION

The SE-330HV measures the resistance change of the NGR relative to the NGR-resistance value determined at the time of calibration. When the resistance change is greater than a threshold amount (2,500 Ω for 100-kΩ systems, 5,000 Ω for 200-kΩ systems), a resistor-fault trip occurs. Calibrate the SE-330HV on new installations, if the NGR is changed, or if the sensing resistor is changed.

**NOTE:** If the SE-330HV is not calibrated and is supplied from the load side of the breaker (non-fail-safe mode), calibrate within the resistor-fault trip time after power-up or it may trip and interrupt its supply. See Section 2.1.5.

The CALIBRATION button is located behind the access cover on the front panel, and it is recessed to prevent inadvertent activation.

**NOTE:** Calibration must be performed with the SE-330HV connected to the sensing resistor and NGR of the installed system.

To calibrate, press and hold the CALIBRATION button until the green CALIBRATED LED turns off and returns to on (if the LED is already off, press and hold until the LED turns on). Calibration takes approximately two seconds. If calibration is not successful, a resistor-fault trip occurs, the RESISTOR FAULT TRIP LED will be on, the CALIBRATED LED will be off, and the DIAGNOSTIC LED will flash the calibration-error code. See Section 2.7.

The SE-330HV may be calibrated remotely using the SE-MON330 software with the USB interface or the communications options.

If latching resistor fault (switch S4) is selected, the calibration-error code flashes until RESET is pressed even if the CALIBRATED LED is on.

The calibration value is stored in non-volatile memory.

### 2.3 TRIP INDICATION AND RESET

Red LED's and indication relays indicate ground-fault and resistor-fault trips. The indication relays K2 (GF) and K3 (RF) operate in fail-safe or non-fail-safe mode. The default is non-fail-safe mode. In this mode, the relays are energized when a fault occurs. The relay mode setting is stored in non-volatile memory and can be set using the SE-MON330 software or network communications.

When a trip occurs with latching operation selected, the SE-330HV remains tripped until reset with the front panel button or the remote-reset input. See Sections 2.1.4.3 and 2.1.4.4. Terminals 15 and 16 are provided for remote reset as shown in Fig. 3. The reset circuit responds only to a momentary closure so that a jammed or shorted button does not prevent a trip. The front-panel RESET button is inoperative when terminal 15 is connected to terminal 16. If non-latching operation is selected, trips and corresponding indication automatically reset when the fault clears and power-up trip memory is defeated even when configuration switch S2 is set to fail-safe. The maximum automatic reset time is 2.8 s.

The red DIAGNOSTIC LED annunciates latched calibration-error and remote trips. See Section 2.7.

When supply voltage is applied with switch S2 set to FAIL-SAFE, the SE-330HV returns to its state prior to loss of supply voltage. When supply voltage is applied with switch S2 set to NON-FAIL-SAFE, SE-330HV trips are reset. When a local, remote, or network reset is issued, both trip LED's will flash if they are off.

Resistor-fault-trip reset can take up to one second. Resistor-fault trip-memory can take up to three seconds after SE-330HV power up.

### 2.4 REMOTE OPERATION

Relays K2 and K3 can be used for remote indication, and terminals 15 and 16 are provided for remote reset. RK-332 Remote Indication and Reset components are shown in Fig. 18. Connect them as shown in Fig. 3. RK-332 components are not polarity sensitive.

Indication relays can be set to fail-safe or non-fail-safe operation using the SE-MON330 software or network



communications. The default mode is non-fail-safe. In non-fail-safe mode, relays energize on fault.

Network-enabled SE-330HV's can be remotely tripped and reset by the network master. The red DIAGNOSTIC LED indicates a network-initiated trip. See Section 2.7. Refer to the appropriate SE-330HV communications manual.

**2.5 RELAY K1 LED**

The yellow RELAY K1 LED follows the state of relay K1 and is on when K1 is energized (contact closed).

**2.6 UNIT HEALTHY OUTPUT**

UNIT HEALTHY relay K4 is energized when the processor is operating. It can be ordered with N.O. or N.C. contacts. See Section 7.

**NOTE:** The output changes state momentarily during a processor reset.

**NOTE:** K4-contact rating is 100 mA maximum.

**2.7 DIAGNOSTIC LED**

The DIAGNOSTIC LED is used to annunciate trips without individual LED indication. The number of short LED pulses between pauses indicates the cause of the trip.

By default, both critical and non-critical diagnostic flash codes are shown. Non-critical diagnostic codes include SD Card status and USB Error status. All other diagnostic codes are considered critical.

Starting with SE-330HV firmware version 2.60 and SE-MON330 software version 3.8, the SE-330HV can be configured to show only critical diagnostic codes. In this configuration, non-critical diagnostic codes will not be indicated with the DIAGNOSTIC LED.

Diagnostic messages are always visible with the SE-MON330.

See Sections 4.2 and 5.

**2.8 ANALOG OUTPUT**

An isolated 4-20-mA output indicates NGR current with full-scale output corresponding to the CT rating. An internal 24-Vdc supply allows the analog output to be connected as a self-powered output. Power from an external supply is required for loop-powered operation. See Fig. 2. A PGA-0520 analog meter can be panel-mounted to display the NGR current. See Fig. 19 and Section 7.

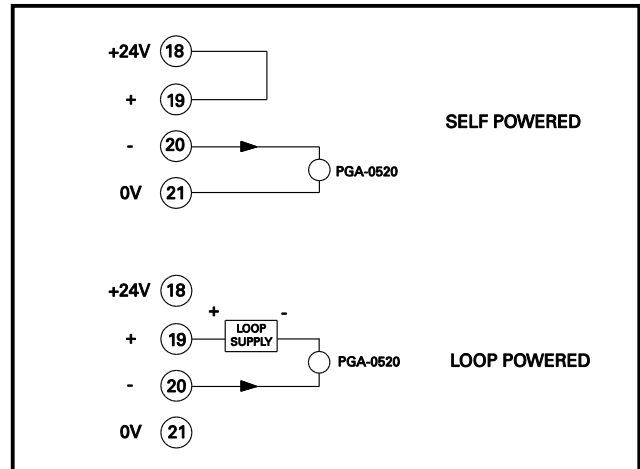

FIGURE 2. Analog-Output Connections.

### 3. INSTALLATION

#### 3.1 SE-330HV

Outline and panel-cutout dimensions for the SE-330HV are shown in Fig. 4. To panel mount the SE-330HV, insert it through the panel cutout and secure it with the four included 8-32 locknuts and flat washers.

If an optional SE-IP65CVR-G Hinged Cover is used, follow the included installation instructions. See Figs. 6 and 7.

All connections to the SE-330HV are made with plug-in, wire-clamping terminal blocks. Each plug-in terminal block can be secured to the SE-330HV by two captive screws for reliable connections.

Outline dimensions and mounting details for surface mounting the SE-330HV are shown in Fig. 5. Fasten the optional surface-mount adapter to the mounting surface and make connections to the adapter terminal blocks. Follow Fig. 5 instructions to mount or remove the SE-330HV.

Ground terminal 7 (G) and connect terminal 6 (R) to the sensing-resistor R terminal.

Use terminal 1 (L1) as the line terminal on ac systems, or the positive terminal on dc systems. Use terminal 2 (L2/N) as the neutral terminal on ac systems or the negative terminal on dc systems. Connect terminal 3 ( $\ominus$ ) to ground.

**NOTE:** Disconnect terminal 1 (L1) and terminal 2 (L2/N) before performing dielectric strength testing of the control panel.

**NOTE:** Connections to terminals 4 (SPG) and 5 (SPGA) are not required when using the SE-330HV hardware revision 10 and higher. However, it is recommended to connect terminal 4 to terminal 5 to maintain backwards compatibility with the older SE-330HV series (hardware revision 01A and lower).

#### 3.2 SENSING RESISTOR

Outline and mounting details for the ER-15KV, ER-25KV, ER-35KV and ER-72KV sensing resistors are shown in Figs. 8, 9, 10, 11, and 12. Install the NGR and the sensing resistor near the transformer or generator. When installed outdoors, a sensing resistor must be installed in a suitable enclosure. Ground sensing-resistor terminal G. Pass the sensing-resistor-to-neutral conductor and the NGR-to-neutral conductor through the ground-fault-CT window as shown in Fig. 3. Separately connect sensing-resistor terminal N and the NGR to the neutral to include neutral connections in the monitored loop. Alternately, if the NGR connection to system neutral need not be monitored, connect terminal N to the NGR neutral terminal. If a ground fault in the sensing-resistor conductor is unlikely, a minimal loss of protection will result if it does not pass through the ground-fault-CT window. See Note 3 in Fig. 3.

Outline and mounting details for the ER-1000HV Sensing Resistor are shown in Fig. 13. This sensing resistor can be used to monitor a low-voltage very-high-resistance NGR. See the simplified diagram in Fig. 14.

**NOTE:** Voltage at terminal N rises to line-to-neutral voltage when a ground fault occurs. The same clearances are required for sensing resistors as for NGR's.

**NOTE:** A parallel ground path created by moisture can result in a false resistor-fault trip. Moisture sources include wind-driven rain or snow, and condensation. Sensing-resistor terminal R and its connection to SE-330HV terminal R, including interposing terminal blocks, must remain dry.

**NOTE:** The neutral-to-sensing-resistor-terminal-N connection is not a neutral conductor as defined in Canadian Electrical Code Section 10-1108 and National Electrical Code Section 250.36(B). It is not required to be 8 AWG (8.36 mm<sup>2</sup>) or larger. Since current through this conductor is always less than 250 mA, a 14 AWG (2.08 mm<sup>2</sup>) conductor insulated to the system voltage is more than sufficient.

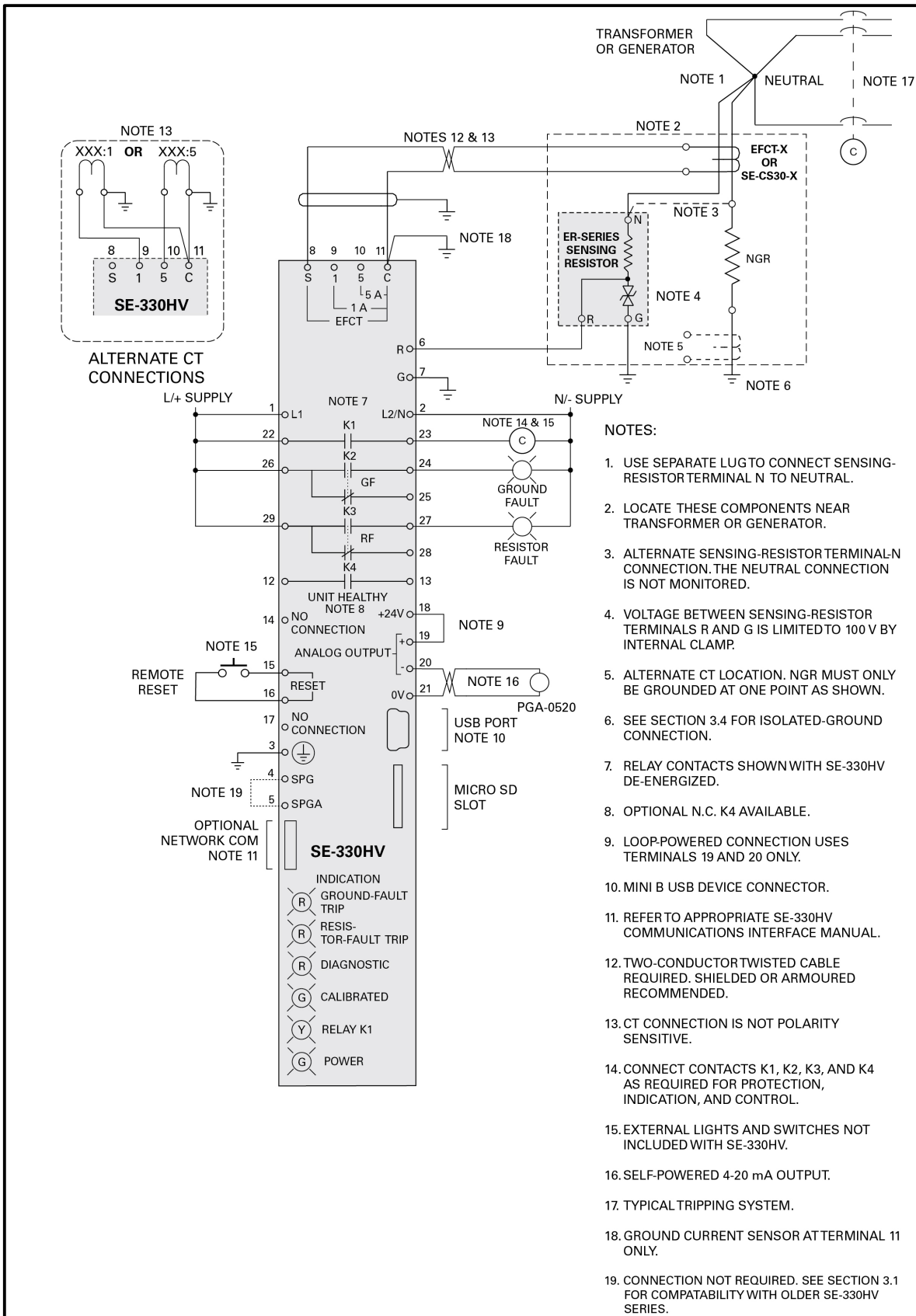

FIGURE 3. SE-330HV Connection Diagram.

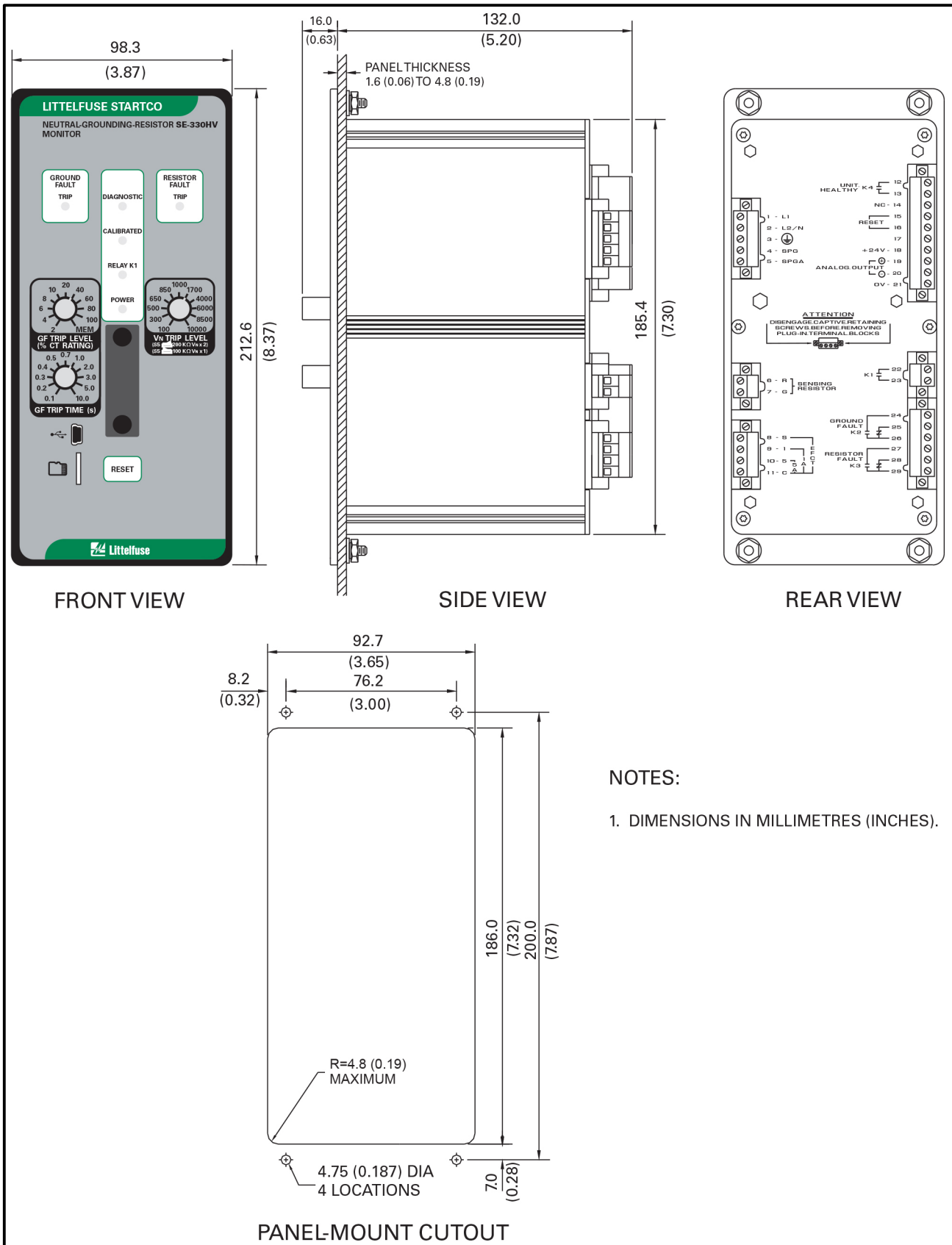

FIGURE 4. SE-330HV Outline and Panel-Mounting Details.

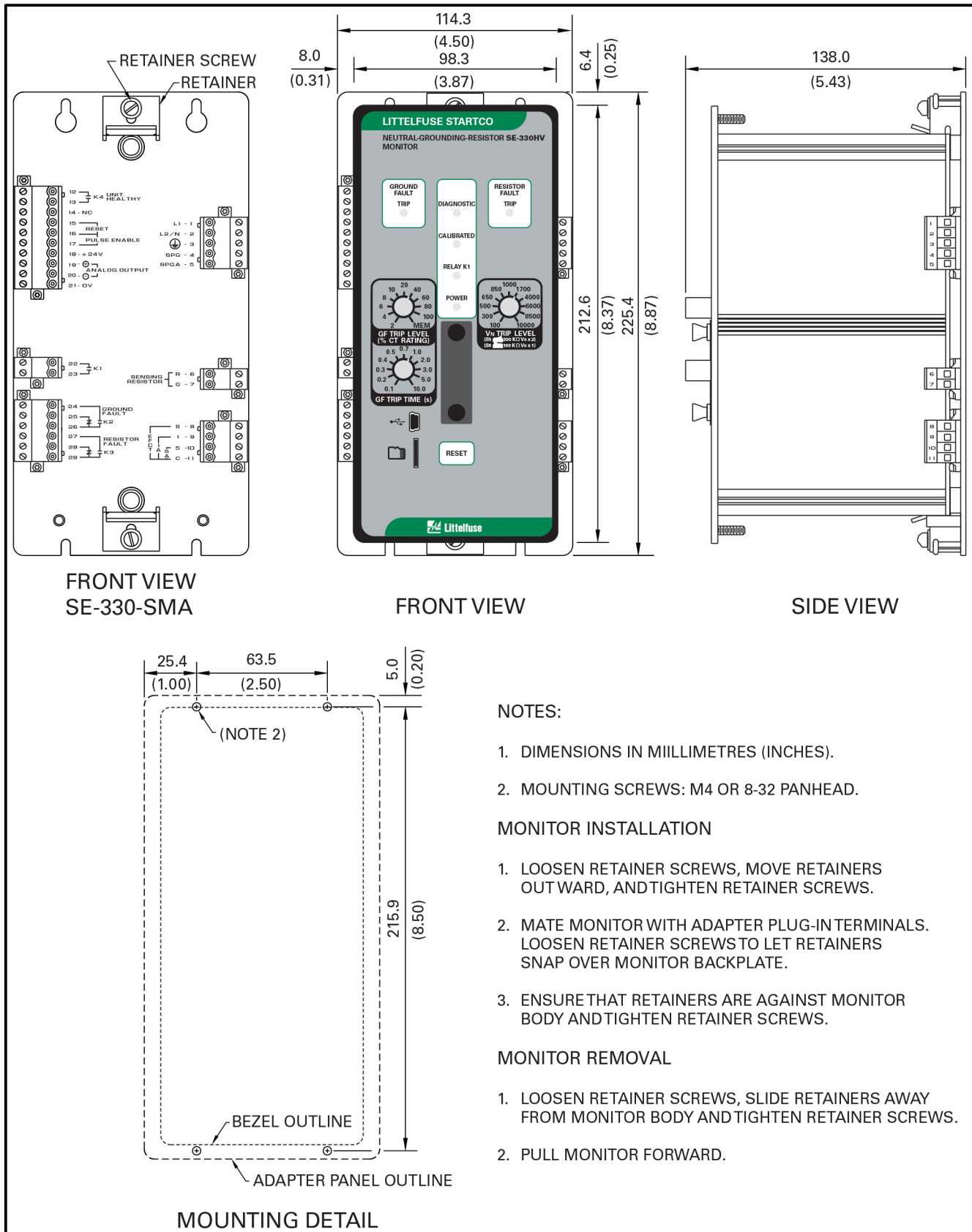

FIGURE 5. SE-330HV Outline and Surface-Mounting Details.

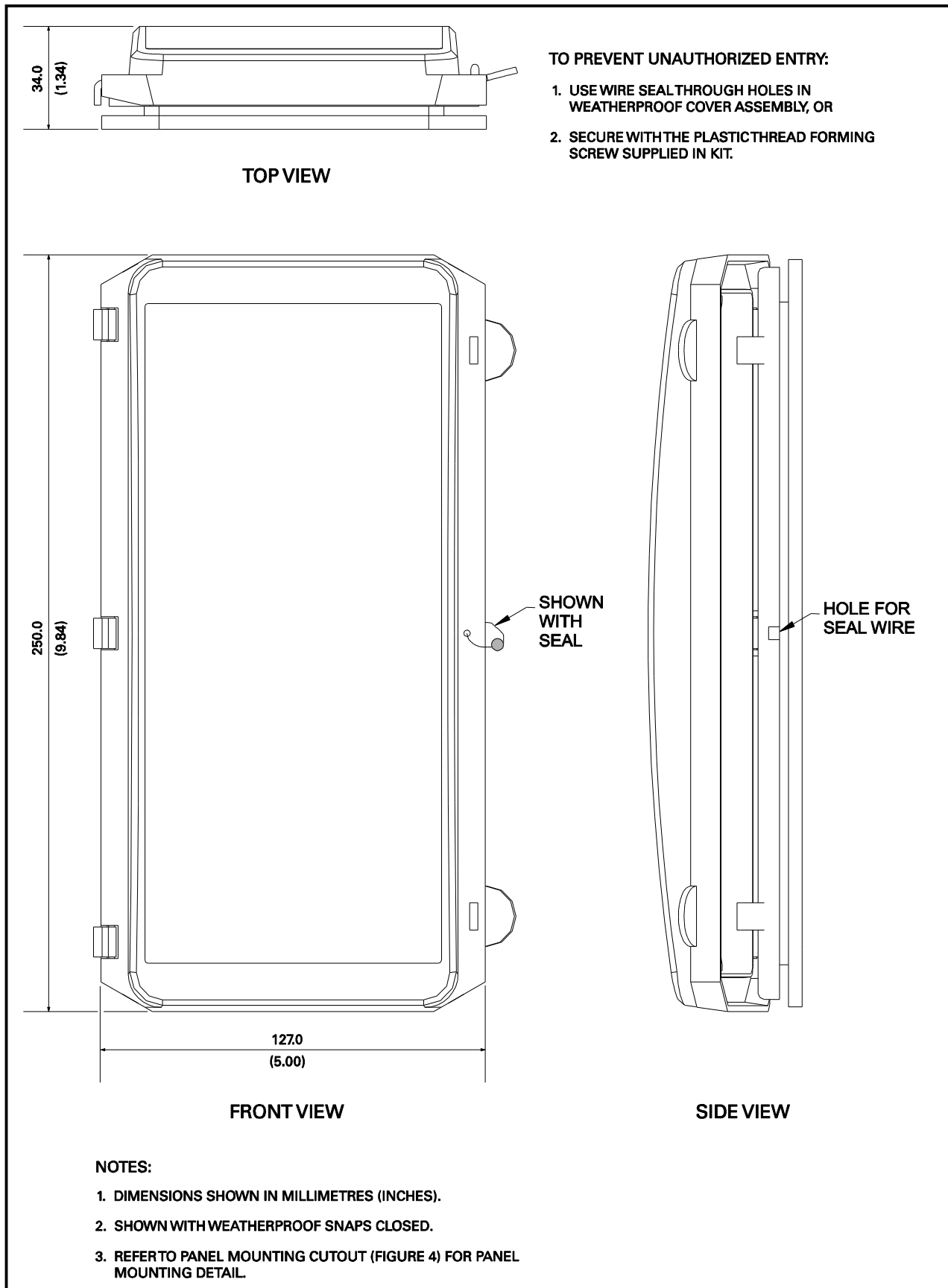

FIGURE 6. SE-IP65CVR-G Weatherproof Cover Outline.

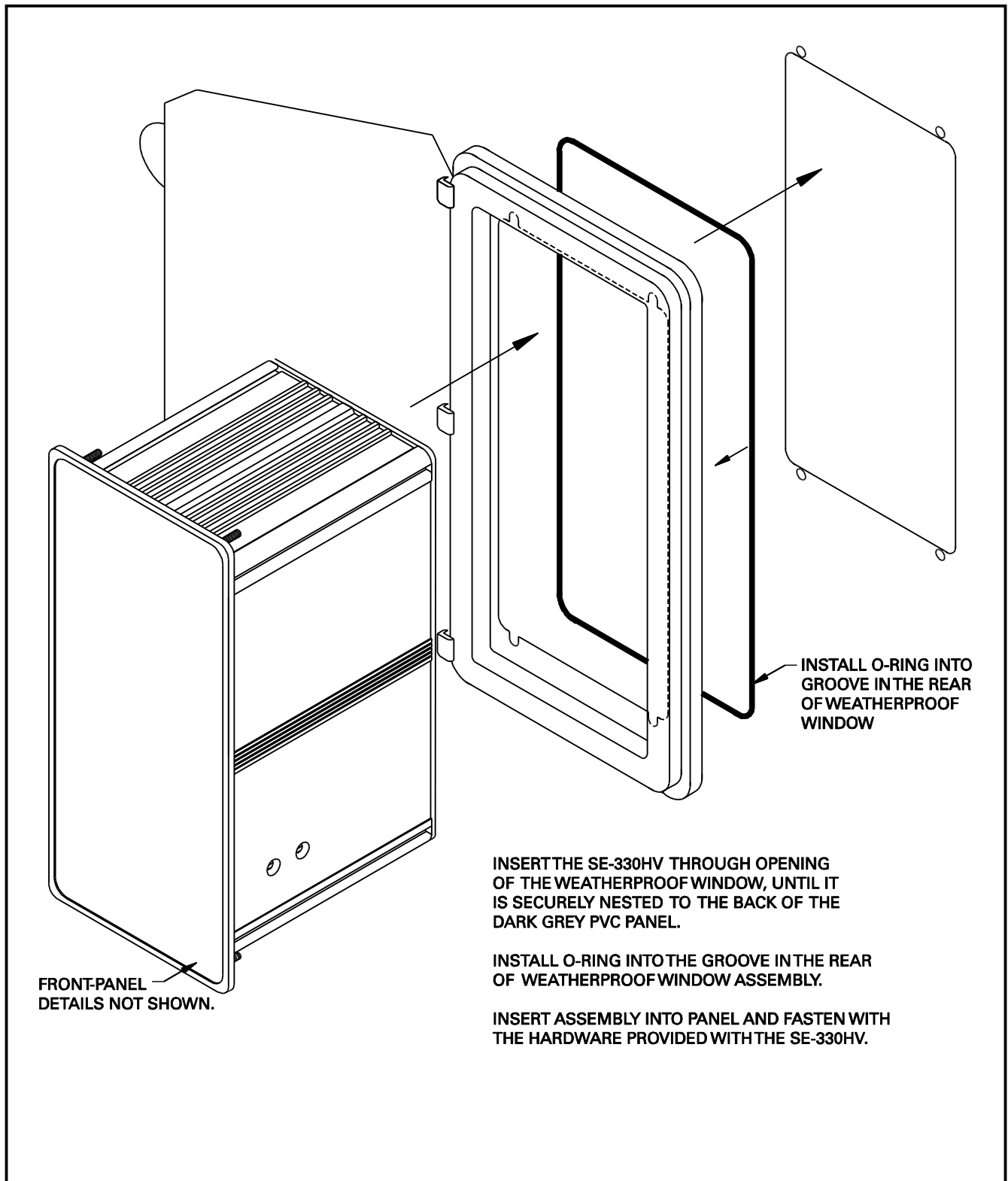

FIGURE 7. SE-IP65CVR-G Weatherproof Cover Installation.

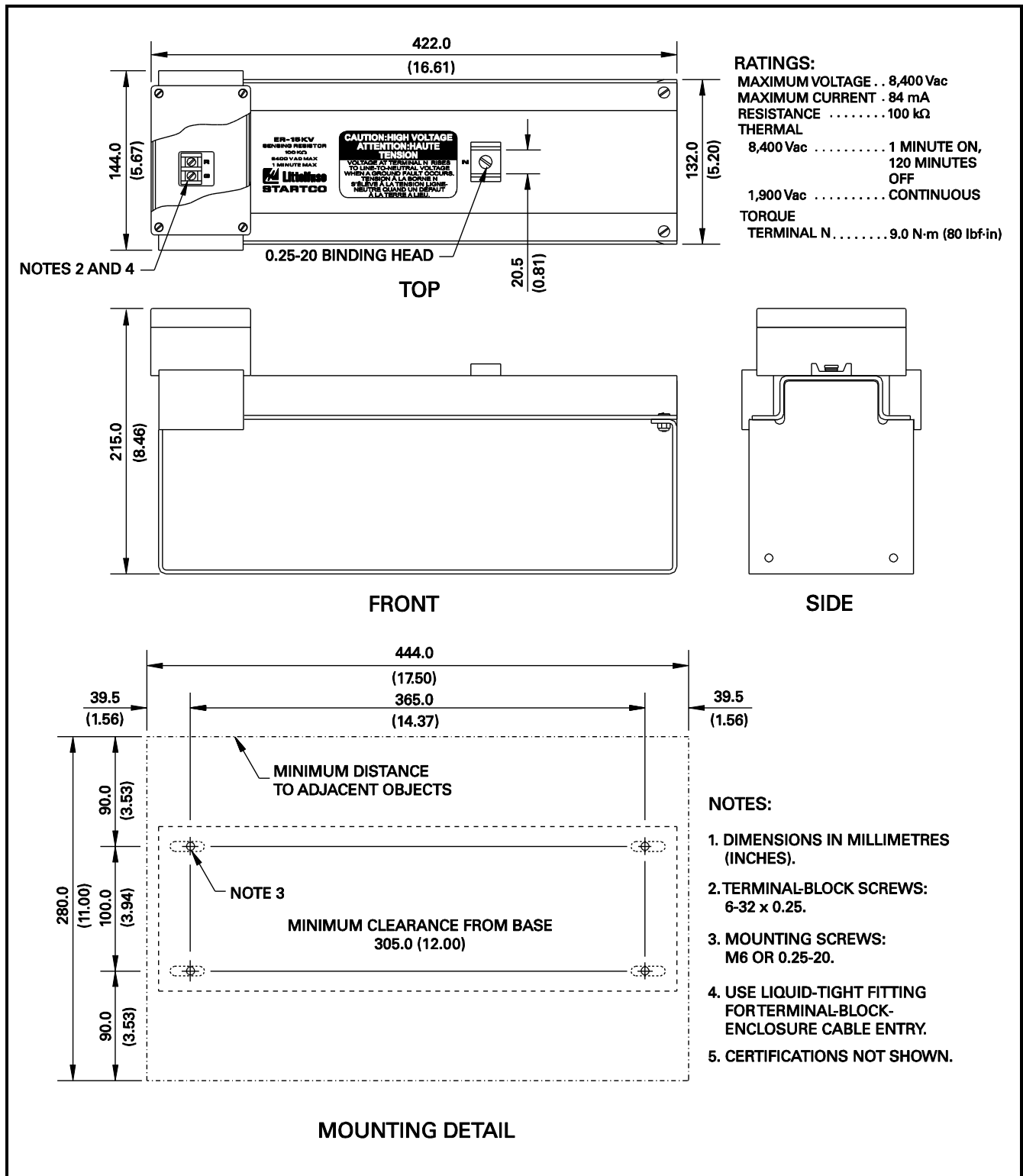

FIGURE 8. ER-15KV Sensing Resistor.



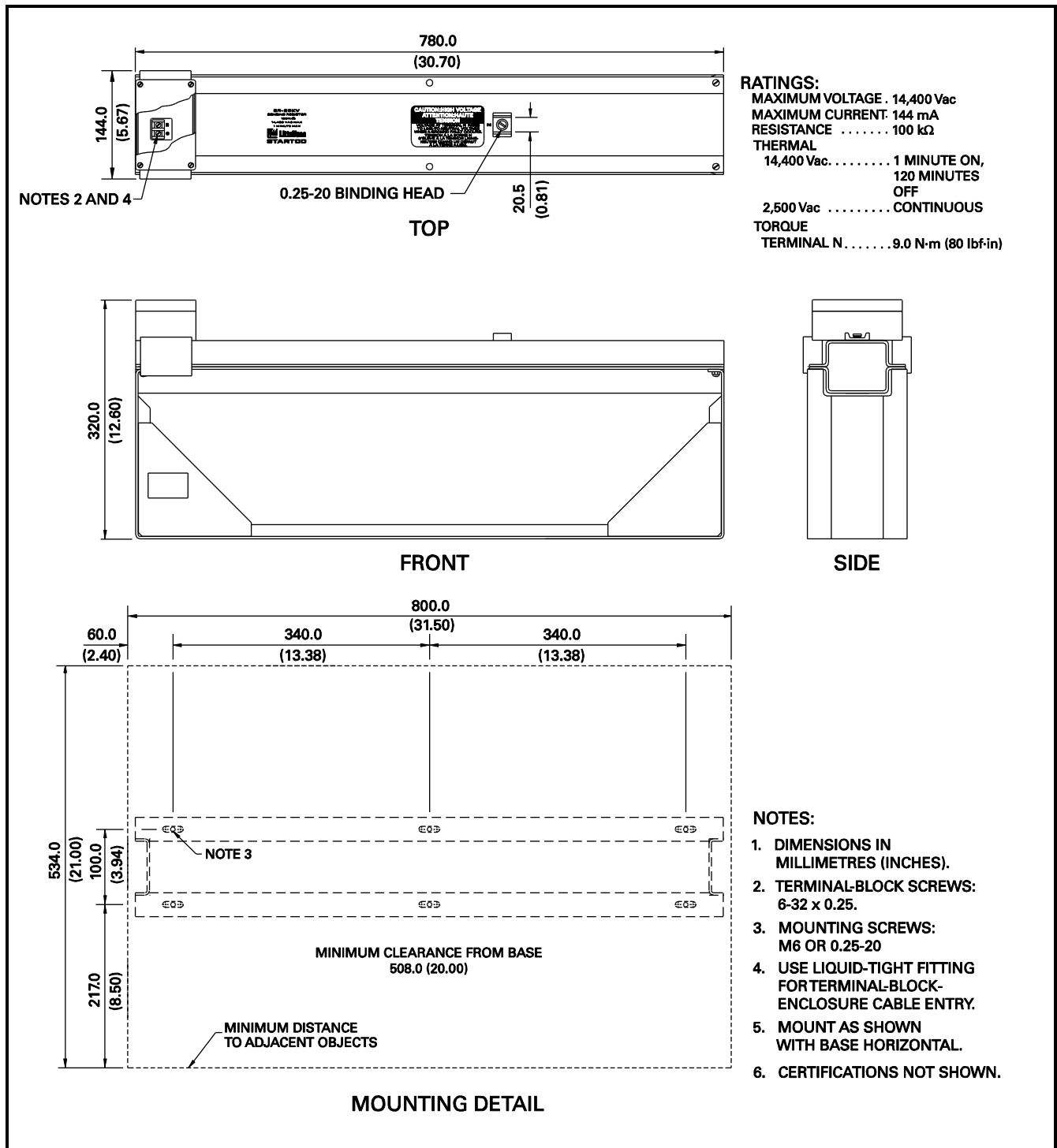

FIGURE 9. ER-25KV Sensing Resistor.

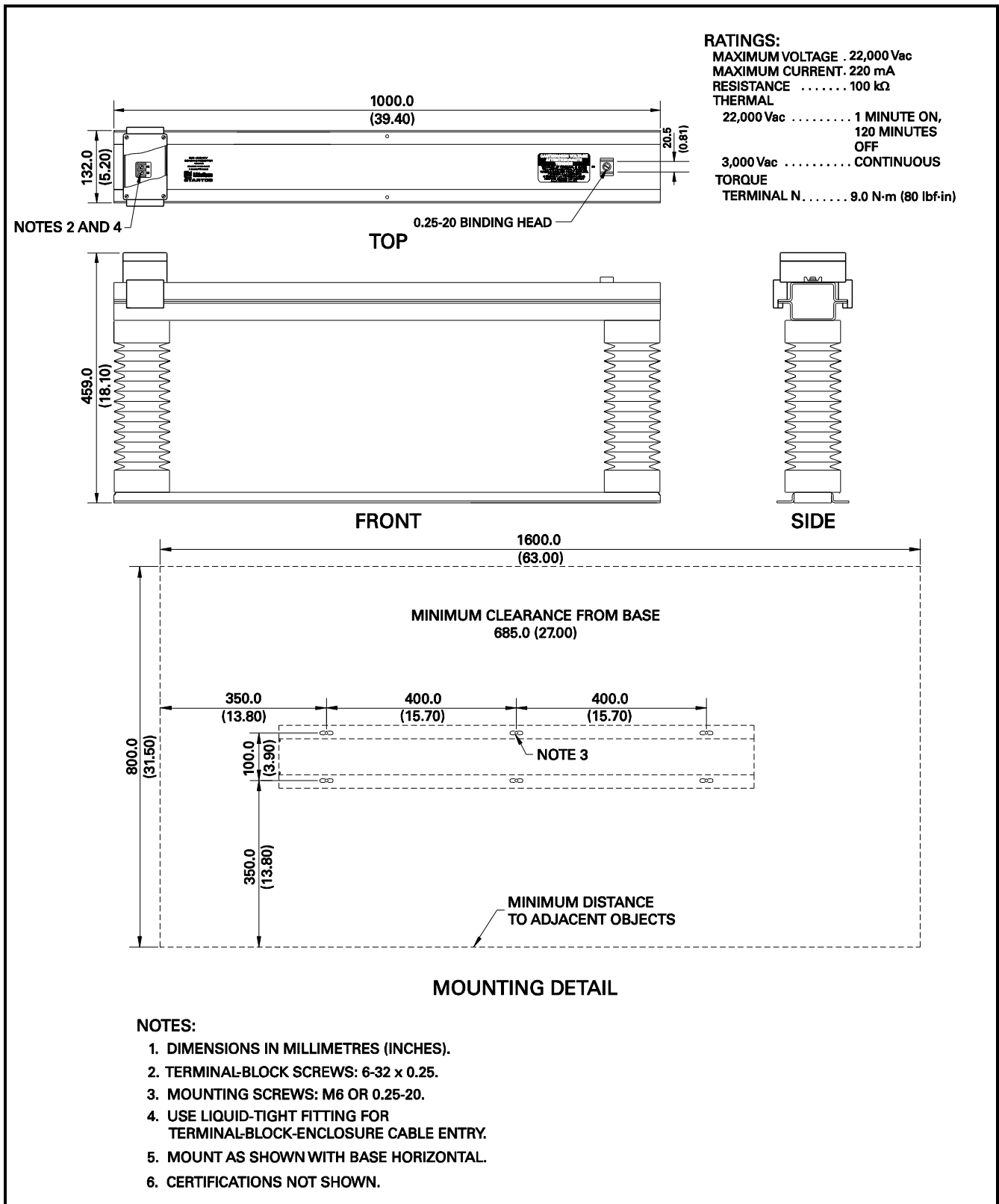
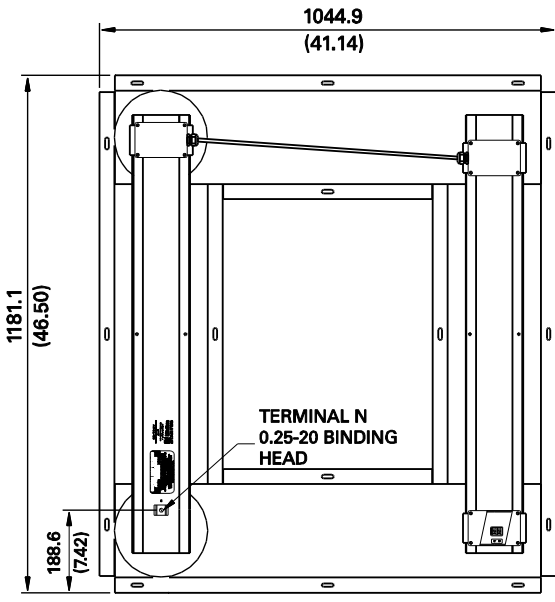
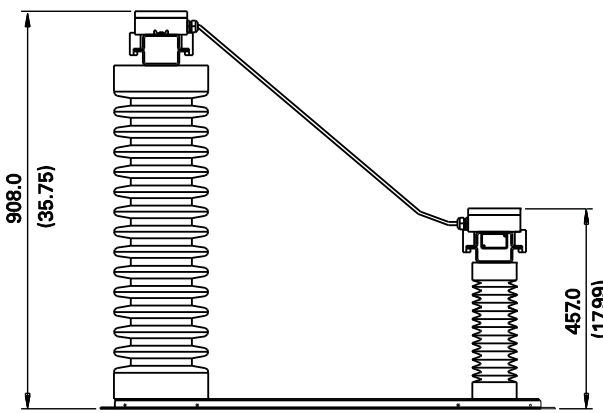

FIGURE 10. ER-35KV Sensing Resistor.



**RATINGS:**  
 MAXIMUM VOLTAGE 44,000 Vac  
 MAXIMUM CURRENT 220 mA  
 RESISTANCE ..... 200 kΩ  
**THERMAL**  
 44,000 Vac ..... 1 MINUTE ON,  
 120 MINUTES  
 OFF  
 6,000 Vac ..... CONTINUOUS  
**TORQUE**  
 TERMINAL N ..... 9.0 N·m (80 lbf·in)

**TOP**



**FRONT**

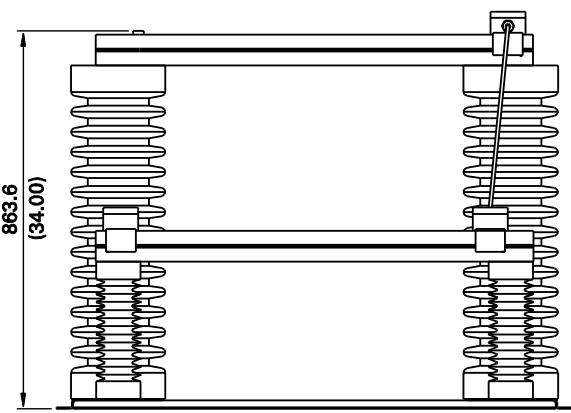

**RIGHT SIDE**

- NOTES:**
1. DIMENSIONS IN MILLIMETRES (INCHES).
  2. TERMINAL-BLOCK SCREWS: 6-32 x 0.25.
  3. MOUNTING SCREWS: M6 OR 0.25-20.
  4. USE LIQUID-TIGHT FITTING FOR TERMINAL-BLOCK-ENCLOSURE CABLE ENTRY.

FIGURE 11. ER-72KV Sensing Resistor Outline.

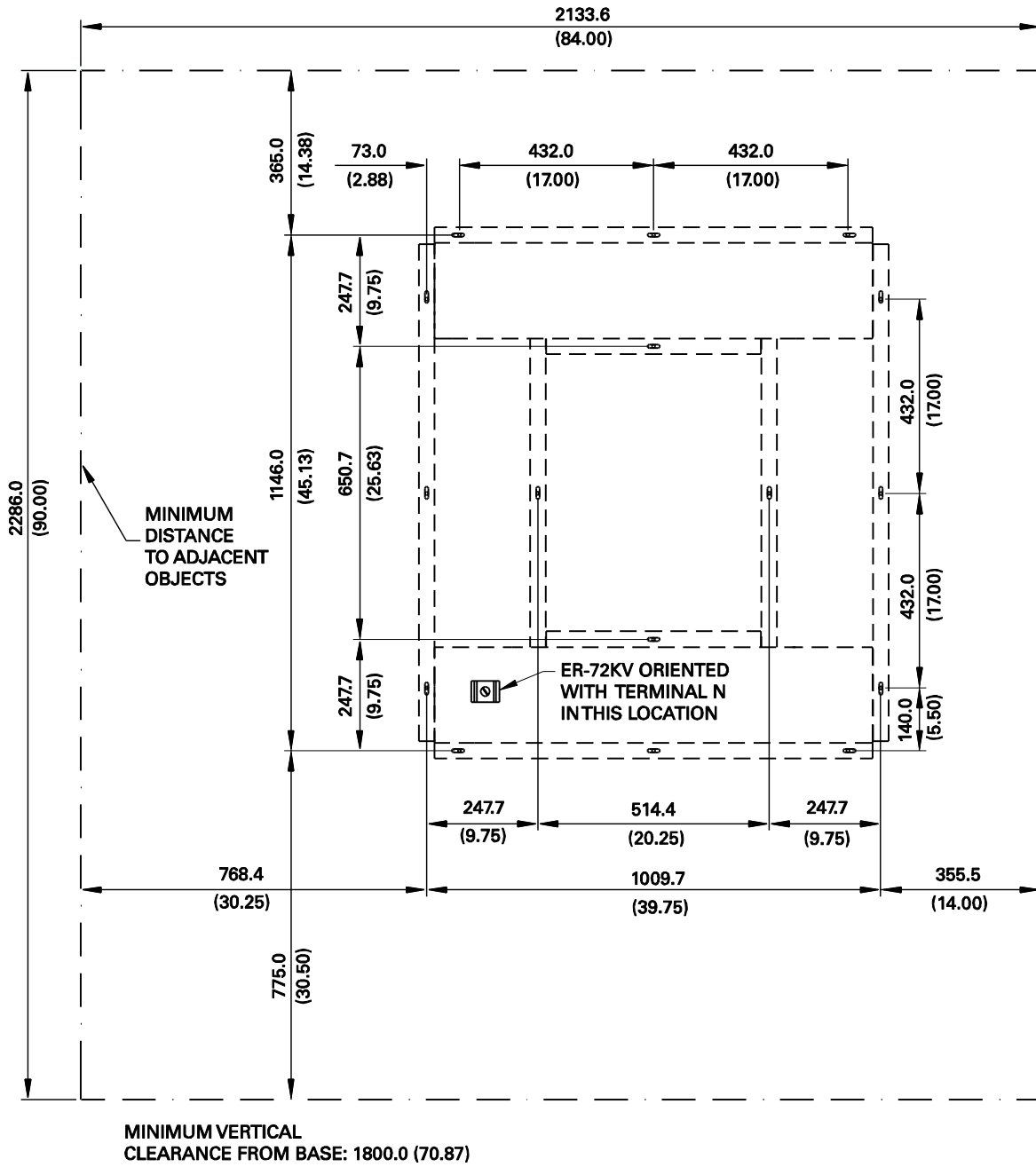

**NOTES:**

1. DIMENSIONS IN MILLIMETRES (INCHES).
2. MOUNTING SCREWS: M6 OR 0.25-20.

FIGURE 12. ER-72KV Sensing Resistor Mounting Details.

**RATINGS:**

MAXIMUM VOLTAGE . 600 Vac  
 MAXIMUM CURRENT. 3 mA  
 RESISTANCE . . . . . 200 kΩ  
 THERMAL . . . . . 600 Vac CONTINUOUS

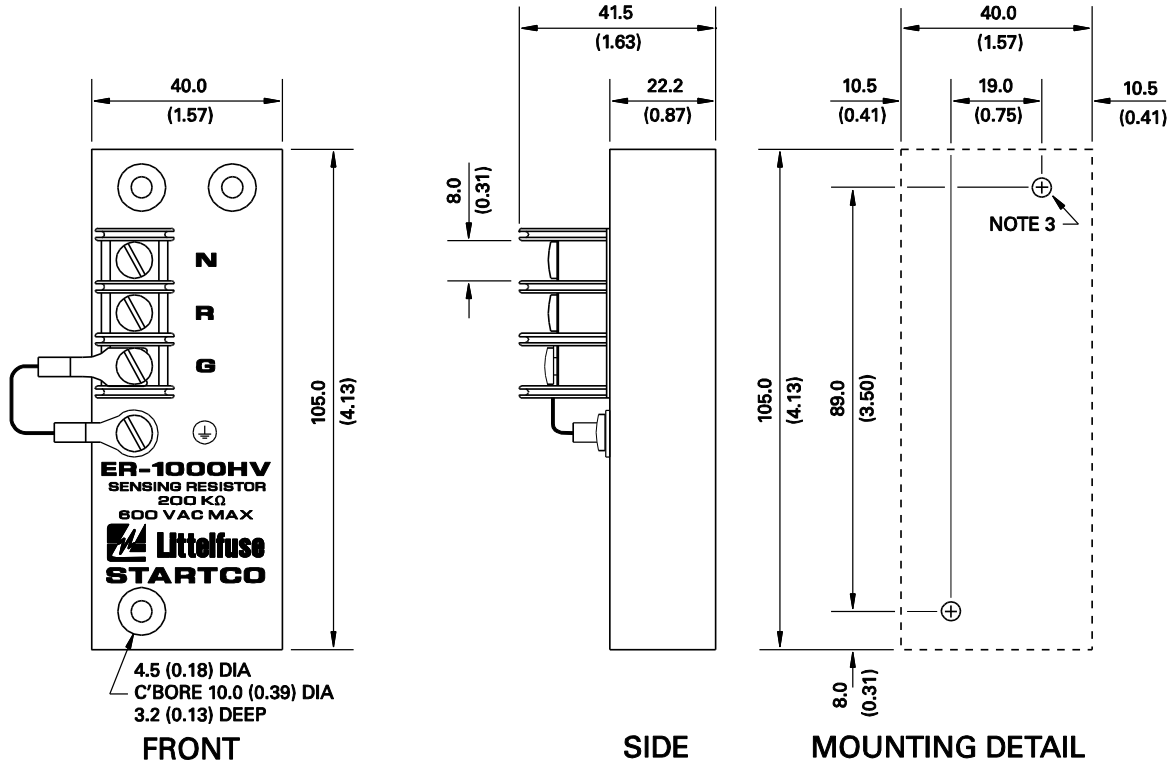

**NOTES:**

1. DIMENSIONS IN MILLIMETRES (INCHES).
2. TERMINAL-BLOCK SCREWS: 6-32 x 0.25.
3. MOUNTING SCREWS: M4 OR 8-32.
4. ENCLOSURE IS ELECTRICALLY CONNECTED TO TERMINAL G THROUGH JUMPER FROM TERMINAL G TO ⊕ SCREW. THIS CONNECTION MAY BE REMOVED FOR DIELECTRIC STRENGTH TESTING. ENSURE THAT THE JUMPER IS INSTALLED AFTER TESTING.

FIGURE 13. ER-1000HV Sensing Resistor.

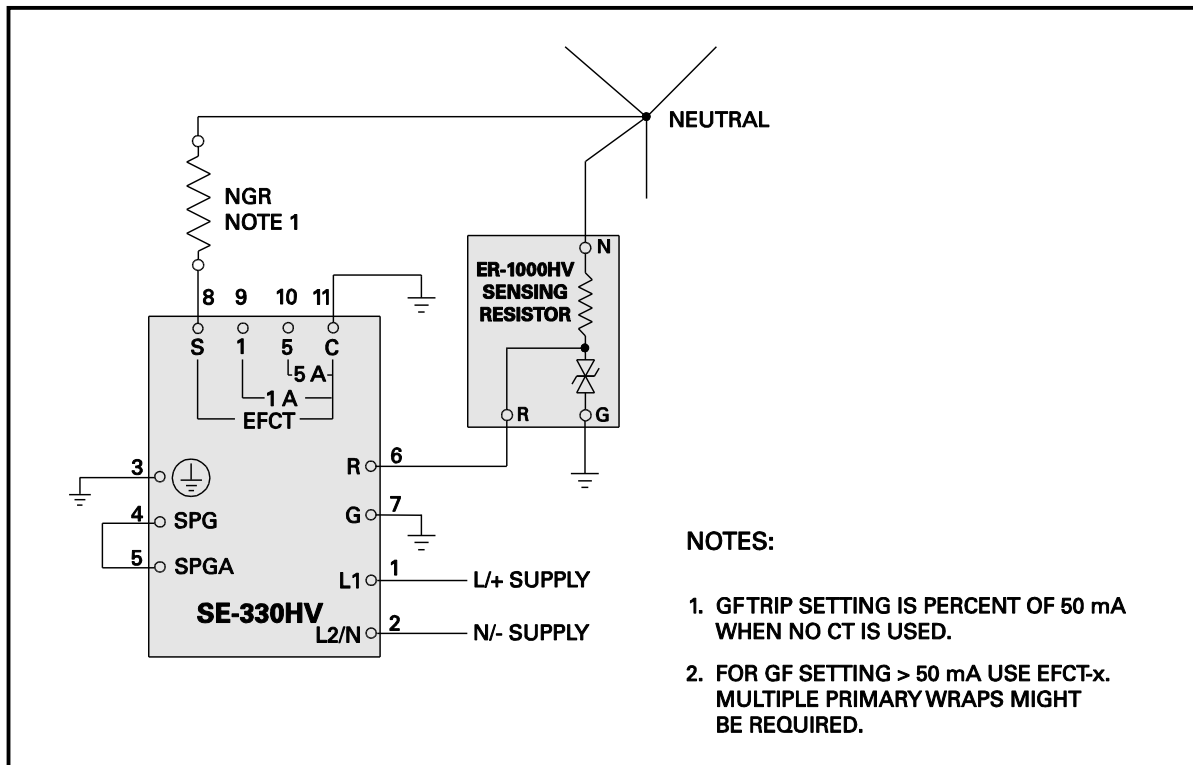

FIGURE 14. ER-1000HV Simplified Connection Diagram.

### 3.3 GROUND-FAULT CT

Select and install a ground-fault CT that will provide the desired trip level. Typically, the CT-primary rating should be approximately equal to the NGR let-through-current rating. This provides an appropriate GF TRIP LEVEL setting range and analog-output scaling. See Sections 2.1.2 and 2.8.

Outline and mounting details for the EFCT- and SE-CS30-series current sensors are shown in Figs. 15, 16, and 17. Ground-fault-CT connections and the preferred ground-fault-CT location are shown in Fig. 3. If a ground fault in the NGR is unlikely, a minimal loss of protection will result if the ground-fault CT monitors the NGR connection to ground rather than its connection to neutral. A minimal loss of protection will also result if the sensing-resistor-to-neutral connection does not pass through the CT window. This alternate CT location is shown in Fig. 3.

The accuracy of a typical current sensor decreases below 5% of its current rating. CT-primary current-injection testing is recommended to verify trip levels below 5% of the CT-primary rating. See Section 9.4. Littelfuse Startco current sensors are designed for use at low levels and respond linearly to 2% current rating.

**NOTE:** The current-sensor insulation class is of no consequence if its secondary is grounded and the conductors through its window are insulated for the system voltage. Bushing type CT's are required for applications using bare conductors on the NGR's neutral side.

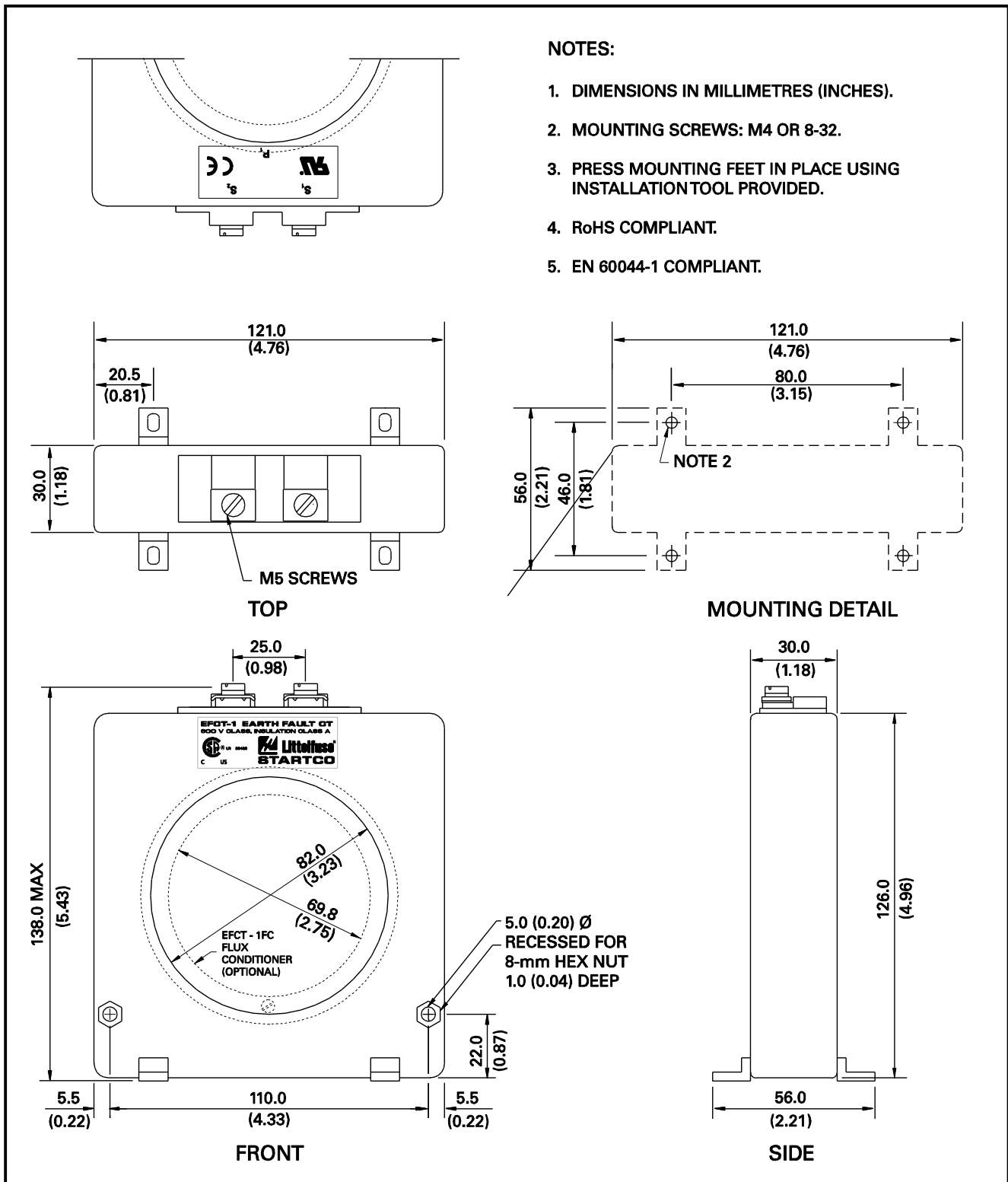

FIGURE 15. EFCT-1 Ground-Fault Current Sensor.

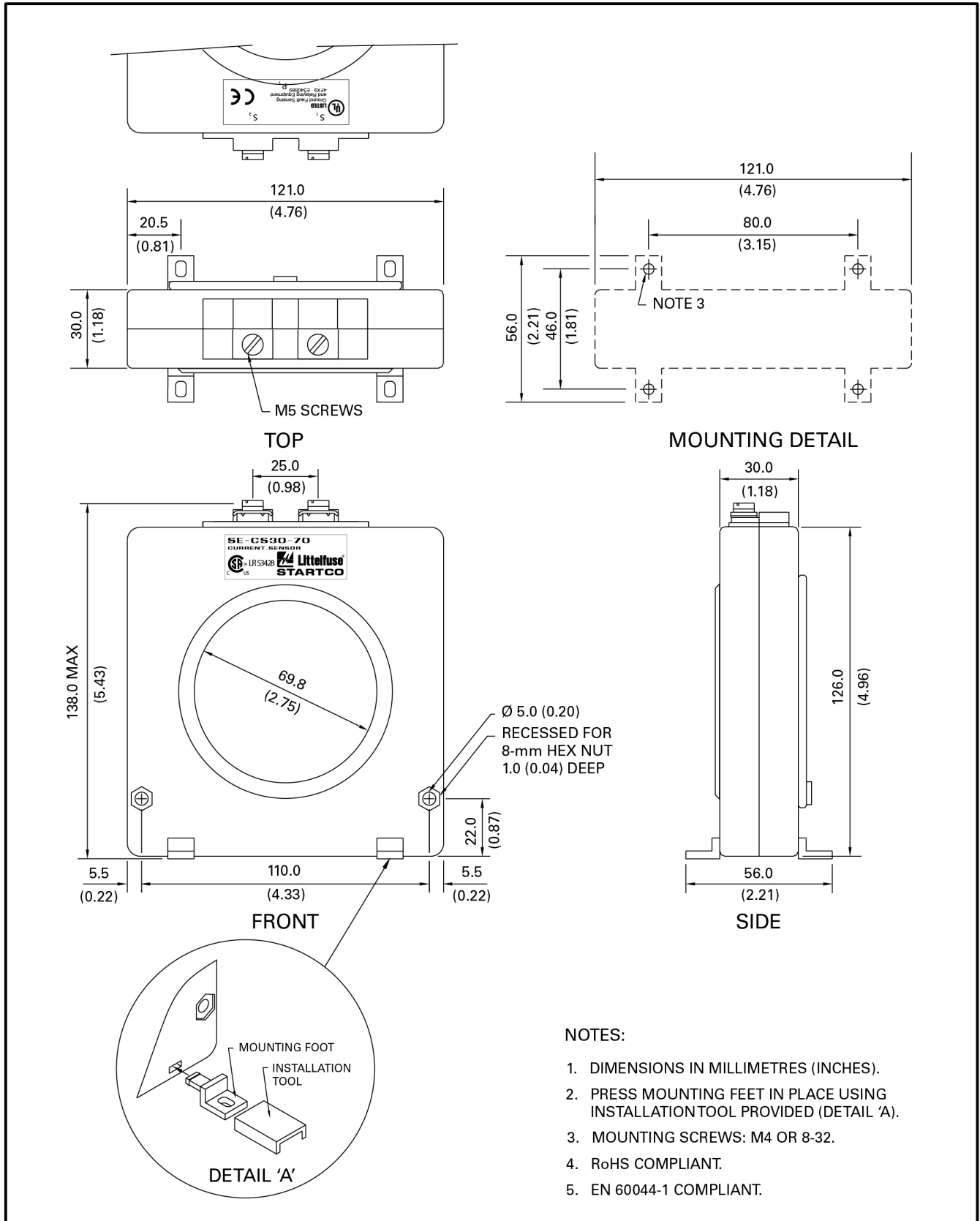

FIGURE 16. SE-CS30-70 Ground-Fault Current Sensor.



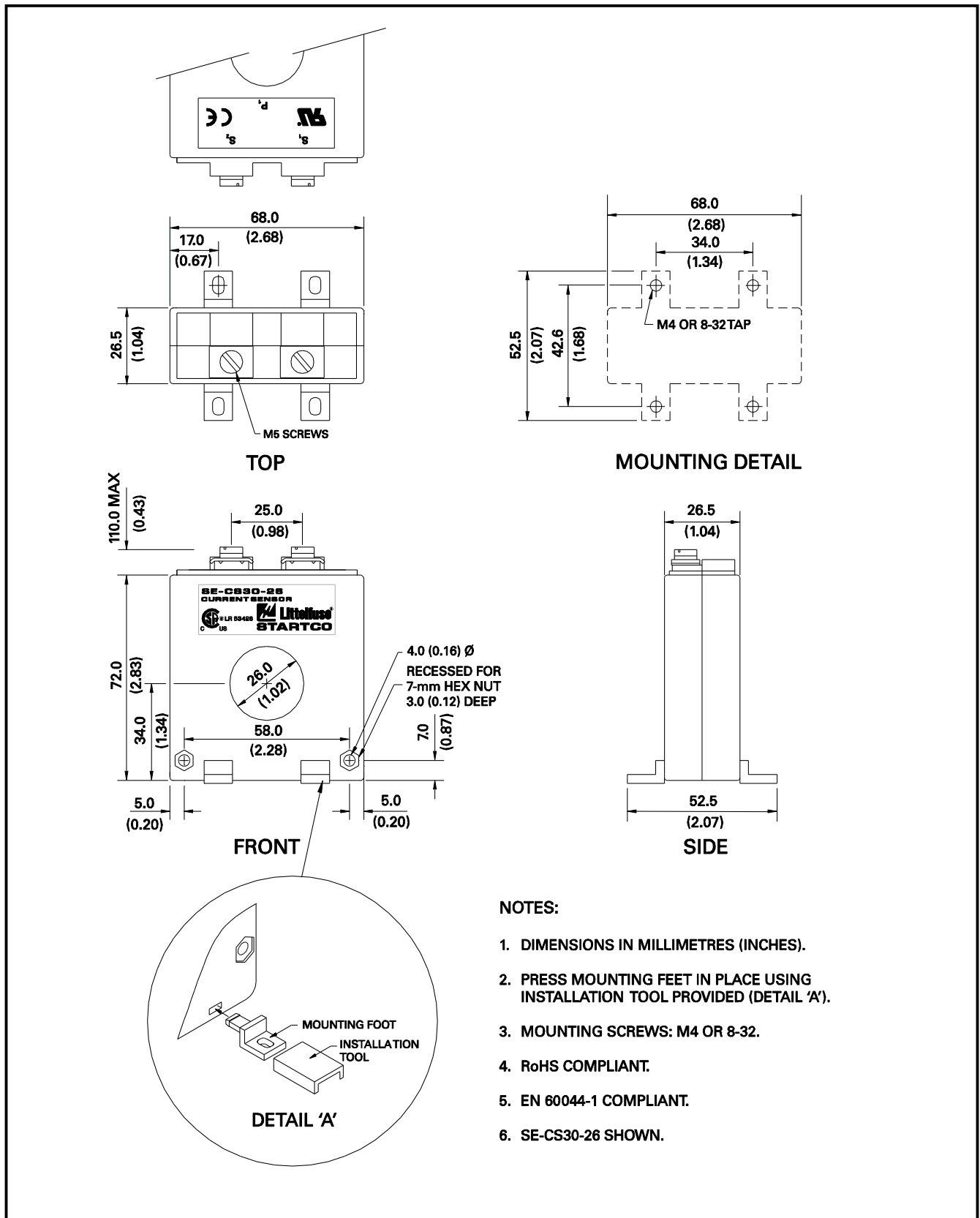

FIGURE 17. EFCT-26 and SE-CS30-26 Ground-Fault Current Sensors.

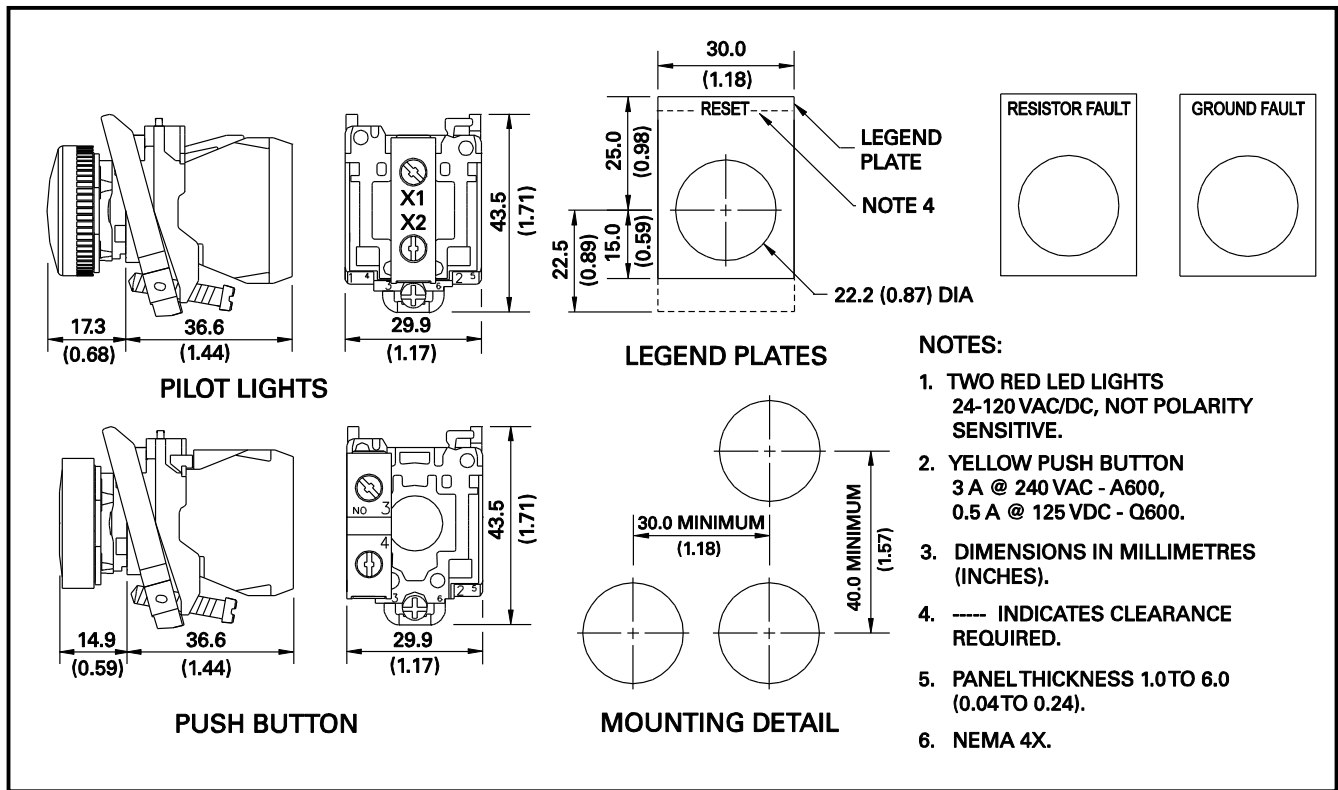

FIGURE 18. RK-332 Remote Indication and Reset.

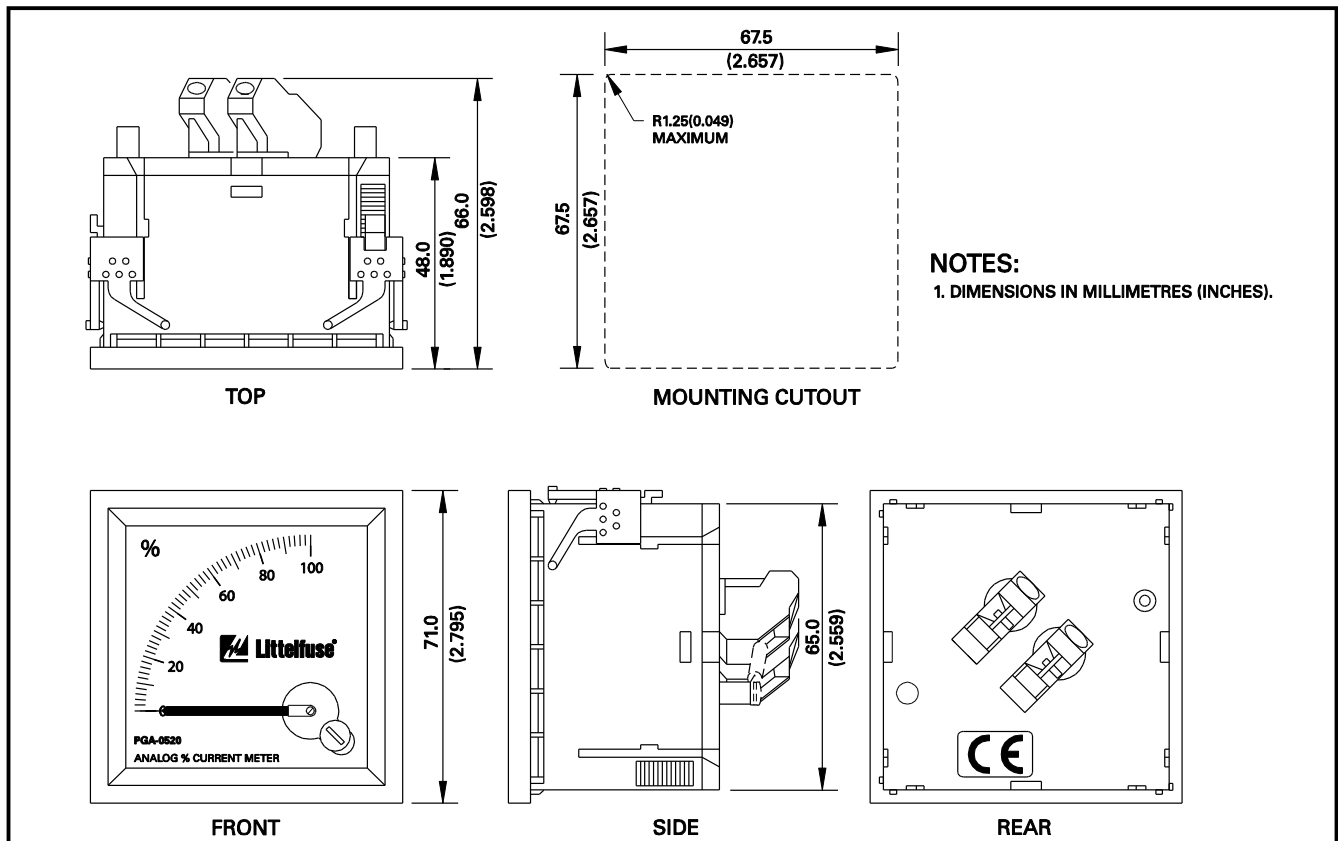

FIGURE 19. PGA-0520 Analog Percent Current Meter.

**3.4 ISOLATED GROUND CONNECTION**

An isolated ground bed can prevent a ground potential rise (GPR) from being transferred to remote equipment. If the G terminals on the sensing resistor and the SE-330HV are connected to an isolated ground, the SE-330HV will be exposed to the GPR. If the GPR is greater than the terminal-block rating, the SE-330HV must be isolated from station ground and precautions must be taken with the power supply and the trip contacts. See Technical Note RG-1 “NGR Monitoring with Isolated Ground Beds” at [www.littelfuse.com/relayscontrols](http://www.littelfuse.com/relayscontrols).

An alternate configuration which allows an SE-330HV to be connected to station ground is shown in Fig. 20. The SE-330HV monitors the series combination of the NGR and the two ground beds. This configuration is acceptable provided the series resistance of the NGR and the ground beds is within the NGR calibration range and ground-bed-resistance changes remain within the trip range. See Section 6.1.

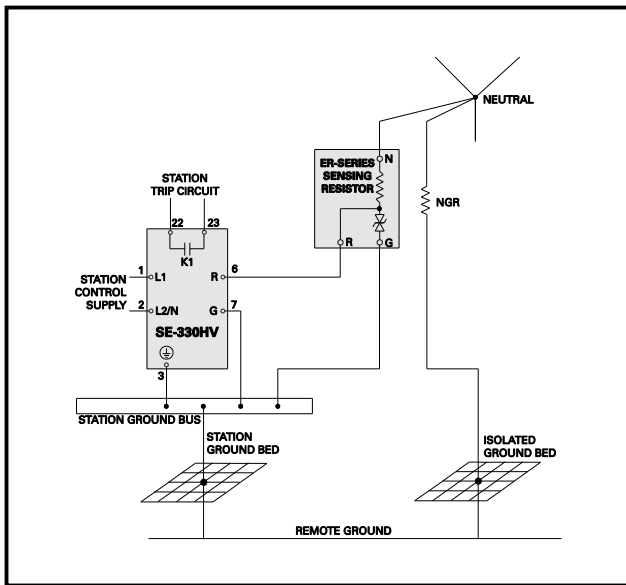

FIGURE 20. Simplified Isolated-Ground Connection.

## 4. DATA INTERFACES

### 4.1 SD CARD

The SE-330HV supports microSD™ data storage. The microSD™ card port is located on the front panel just below the USB port. The microSD™ card is used for long-term data logging of measured values and for firmware upgrades.

**NOTE:** SD card performance may vary by manufacturer, model, and with varying environmental conditions. The included microSD™ card has a temperature rating of -25 to 85°C (-13 to 140°F). For applications colder than -25°C (-13°F), use an Industrial-Grade microSD™ card.

**NOTE:** SD card usage is intended for use with the SE-330HV only. Do not store other data on the SD card – files may be automatically deleted.

#### 4.1.1 DATALOGGING

When a microSD™ card is installed, the SE-330HV looks for a directory called “Datalogging”. If this directory exists, data logging will automatically start after the card is indexed (indexing may take several minutes depending on the size of the card and the number of files).

The log is updated every two seconds and it includes measured values, configuration parameters, and trip status. A new log file is created at the start of each day. If previous log files exist and the microSD™ card has less than 20 MB of free space, the oldest datalogging file will automatically be deleted before a new file is created.

The red DIAGNOSTIC LED may indicate an SD Card error. See Sections 2.7 and 5. Approximately 3 GB of data is generated per year of logging.

#### 4.1.2 FIRMWARE UPGRADE

Firmware upgrades are performed using a microSD™ card in conjunction with configuration switch S8. See Section 2.1.4.6. The SE-Flash software is not required.

To upgrade the SE-330HV firmware, insert a microSD™ card containing the firmware upgrade file (.S19 format) in the root directory of the SD card and set switch S8 to UPGRADE within 30 seconds of card installation. If S8 is switched to UPGRADE after 30 seconds, the upgrade process will not occur. If the microSD™ card is inserted after S8 is switched to UPGRADE, switch S8 to RUN and then back to UPGRADE. The SE-330HV evaluates firmware upgrade files found in the root directory of the microSD™ card and uses the first valid file.

Ensure that the DIAGNOSTIC LED is off before beginning the firmware upgrade process.

The red DIAGNOSTIC LED blinks rapidly while the firmware upgrade is running and the SE-330HV may reset multiple times during the upgrade process. Do not remove the SD card or power off the SE-330HV until the DIAGNOSTIC LED has stopped blinking rapidly for at least 30 seconds. If the upgrade is not successful, the DIAGNOSTIC LED will indicate an SD Upgrade Error. See Section 5. Set switch S8 back to RUN for normal operation.

If a firmware upgrade fails, the existing firmware is not overwritten.

A record of the upgrade can be found in “upgrade\_log\_<SN>.txt” on the microSD™ card. This file is updated each time an upgrade is performed.

**NOTE:** The maximum microSD™ card storage capacity is 32 GB for SE-330HV hardware revision 16 and higher. The maximum microSD™ card storage capacity is 4 GB for SE-330HV hardware revision 15 and lower.

### 4.2 USB INTERFACE

Use the SE-MON330 software (version 3.8 or newer) to access set-points, measured values, and trip records through the mini B USB interface located on the front panel. The following data can be viewed:

- Front-panel and configuration-switch settings
- Neutral voltage and neutral current
- Resistance change from the calibrated value
- Trip status
- Trip records, 100 date and time stamped
- Firmware version and serial number

The following values can be viewed and adjusted:

- Ground-fault trip setting (when front-panel GF Trip Level is set to MEM)
- K2 ground-fault relay output operating mode
- K3 resistor-fault relay output operating mode
- Clock settings
- Trip records can be cleared
- Remote calibration
- Resistor-fault trip time
- Resistor-fault trip level
- Geo-magnetic filter
- Critical and non-critical diagnostics codes

Ensure the real-time clock is set to the correct time prior to normal operation. Trip records and on-board datalogging information include date and time readings from the clock. Refer to the SE-MON330 software help file.

### 4.3 NETWORK COMMUNICATIONS

The optional communications interfaces include a single CAN port and dual Ethernet ports supporting cable, fiber<sup>(1)</sup>, or both cable and fiber. Protocols include:

- DeviceNet over CAN (ordering option 1)
- EtherNet/IP over cable or fiber (ordering options 3, 4, and 5)
- Modbus TCP over cable or fiber (ordering options 3, 4, and 5)
- IEC 61850 over cable or fiber (ordering options 6, 7, and 8) – also includes Modbus TCP

Refer to the appropriate SE-330HV communications-interface manual for details.

<sup>(1)</sup> Uses the plug-in style SC connector.

## 5. TROUBLESHOOTING

PROBLEM	DIAGNOSTIC LED FLASH CODE <sup>(1)</sup>	SOLUTION
POWER LED off.		Check if supply voltage is present on terminals 1 and 2. If present, an overvoltage may have caused the power supply to shutdown. Cycle supply voltage. If POWER LED remains off, return unit for repair.
POWER LED flashes.		A power-supply overload has occurred. Cycle supply voltage. If problem persists, consult Littelfuse Startco.
<b>Calibration-Error Trip</b> DIAGNOSTIC LED flash code	1 L - 1 S - 1 L	The total resistance of the NGR and sensing-resistor circuit is outside the calibration range. Verify that switch S5 is set to match the resistance of the sensing resistor, check the resistance of the NGR, and verify the sensing-resistor circuit. See Section 9.2 for sensing-resistor tests. Repeat the calibration procedure after the open or shorted condition has been corrected. <b>Critical diagnostic code.</b> GF LED <sup>(2)</sup> : No Change, RF LED <sup>(2)</sup> : ON, K1:Trip
<b>Remote Trip</b> DIAGNOSTIC LED flash code	1 L - 2 S - 1 L	The SE-330HV was tripped by a signal from network communications. Press RESET to clear the trip. <b>Critical diagnostic code.</b> GF LED <sup>(2)</sup> : ON, RF LED <sup>(2)</sup> : ON, K1:Trip
<b>A/D-Converter-Error Trip</b> DIAGNOSTIC LED flash code	1 L - 4 S - 1 L	An A/D-converter error was detected. Press RESET to clear the trip. If the problem persists, consult Littelfuse Startco. <b>Critical diagnostic code.</b> GF LED <sup>(2)</sup> : No Change, RF LED <sup>(2)</sup> : ON, K1:Trip
<b>SD Card</b> DIAGNOSTIC LED flash code	1 L - 5 S - 1 L	SD Card is full or a write error occurred. Delete files or use a different microSD™ card. <b>Non-critical diagnostic code.</b> GF LED <sup>(2)</sup> : No Change, RF LED <sup>(2)</sup> : No Change, K1:No Change  If this diagnostic was caused during an attempt to upgrade the firmware, follow this alternate process: - remove supply from SE-330HV - insert a microSD card containing the firmware upgrade file in the root directory of the SD card - power on the SE-330HV - set switch S8 to UPGRADE within 30 seconds - the upgrade should continue as described in Section 4.1.2
<b>Watchdog Trip</b> DIAGNOSTIC LED flash code	1 L - 6 S - 1 L	A watchdog trip results in a processor reset. During reset, UNIT HEALTHY relay K4 will be de-energized. After a reset, UNIT HEALTHY relay K4 will be energized. Press RESET to clear the trip. If the problem persists, consult Littelfuse Startco. <b>Critical diagnostic code.</b> GF LED <sup>(2)</sup> : ON, RF LED <sup>(2)</sup> : ON, K1:Trip
<b>CPU Trip</b> DIAGNOSTIC LED flash code	1 L - 7 S - 1 L	The CPU has detected a system fault. Press RESET to clear the trip. <b>Critical diagnostic code.</b> GF LED <sup>(2)</sup> : ON, RF LED <sup>(2)</sup> : ON, K1:Trip
<b>Non-Volatile Memory Error Trip</b> DIAGNOSTIC LED flash code	1 L - 8 S - 1 L	An error was detected in the Non-Volatile Memory. Press RESET to clear the trip. If the problem persists, consult Littelfuse Startco. <b>Critical diagnostic code.</b> GF LED <sup>(2)</sup> : ON, RF LED <sup>(2)</sup> : ON, K1:Trip
<b>SD Upgrade Error</b> DIAGNOSTIC LED flash code	1 L - 9 S - 1 L	An error occurred during the flash-memory upgrade procedure. Ensure that the firmware upgrade file is correct or use a different microSD™ card. <b>Critical diagnostic code.</b> GF LED <sup>(2)</sup> : No Change, RF LED <sup>(2)</sup> : No Change, K1:No Change

PROBLEM	DIAGNOSTIC LED FLASH CODE <sup>(1)</sup>	SOLUTION
<b>USB Error</b> Diagnostic LED Flash Code	1 L – 10 S – 1 L	A USB algorithm timeout has been detected. Remove and reconnect the USB cable and cycle supply voltage. If the problem persists contact Littelfuse Startco. <b>Non-critical diagnostic code.</b> GF LED <sup>(2)</sup> : No Change, RF LED <sup>(2)</sup> : No Change, K1:No Change
DIAGNOSTIC LED = Solid Red		SE-330HV processor failed to start. Cycle supply. If problem persists, consult Littelfuse Startco. K1: De-energized.
Pressing RESET does not clear trips.		Trip condition is still present. Locate and correct.  The RESET button is disabled if remote-reset terminals 15 and 16 are connected. Replace shorted remote-reset switch or issue Reset command from the communications network.
UNIT HEALTHY relay K4 momentarily changes state.		Occurs when processor is reset.
No analog-output current.		The output at terminals 19 and 20 requires a voltage source. See Fig. 2 for analog-output connections. See Section 9.3 for the analog-output tests.

**NOTES:**

<sup>(1)</sup> L = long pause, S = short flash.

<sup>(2)</sup> When LED is on, corresponding indication relay is energized when in the non-fail-safe mode or de-energized when in the fail-safe mode.

## 6. TECHNICAL SPECIFICATIONS

### 6.1 SE-330HV

Supply:

Option 0 .....	30 VA, 120 to 240 Vac (+10, -45%) 50/60 Hz, 20 W, 110 to 250 Vdc (+10, -25%)
Option 2 .....	20 W, 48 Vdc (+50, -25%), 35 VA, 48 Vac (+10, -45%) 50/60 Hz

Power-Up Time.....3 s at 120 Vac

AC Measurements.....Discrete Fourier Transform. 16 samples per cycle, 50 or 60 Hz

Resistor-Fault Circuit:

Neutral-To-Ground Voltage Trip Levels<sup>(1)</sup>:

ER-15KV to ER-35KV .....	100; 300; 500; 650; 850; 1,000; 1,700; 4,000; 6,000; 8,500; 10,000 Vac
ER-1000HV, ER-72KV .....	200; 600; 1,000; 1,300; 1,700; 2,000; 3,400; 8,000; 12,000; 17,000; 20,000 Vac

Accuracy.....10% of setting

3 dB Frequency Response:

S6 = 50 Hz.....	25 to 85 Hz
S6 = 60 Hz.....	30 to 90 Hz

NGR Calibration Range:

ER-15KV to ER-35KV .....	0 to 10 kΩ
ER-1000HV, ER-72KV .....	0 to 20 kΩ

Trip Resistance,  $V_N = 0$ :

ER-15KV to ER-35KV:	
Range <sup>(5)</sup> .....	1.25 to 3.75-kΩ change ± 1 kΩ

Default .....± 2.5-kΩ change

ER-1000HV, ER-72KV:

Range <sup>(5)</sup> .....	2.5 to 7.5-kΩ change ± 2 kΩ
----------------------------	--------------------------------

Default .....± 5-kΩ change

DC-Voltage Rejection:

ER-15KV to ER-35KV .....	125 Vdc
ER-1000HV, ER-72KV .....	250 Vdc

Trip Time.....12 to 60 s ± 1 s

Trip Hold-Off Level.....5% of CT-Primary Rating

Trip Mode.....Latching/Non-Latching

Ground-Fault Circuit:

Trip Level .....	2, 4, 6, 8, 10, 20, 40, 60, 80, 100% of CT-Primary Rating or 2 to 100% using MEM parameter
Trip Time.....	0.1, 0.2, 0.3, 0.4, 0.5, 0.7, 1.0, 2.0, 3.0, 5.0, 10.0 s
Trip-Level Accuracy .....	Maximum of 1% of CT-Primary Rating or 3% of Setting <sup>(2)</sup>

Trip-Time Accuracy.....10% of Setting, 20 ms minimum

3 dB Frequency Response:

S6 = 50 Hz.....	25 to 85 Hz
S6 = 60 Hz.....	30 to 90 Hz

Maximum CT Lead Resistance:

EFCT & SE-CS30.....	5 Ω
Other CT's .....	Consult CT Curve

CT-Input Burden:

5-A Input .....	< 0.01 Ω
1-A Input .....	< 0.05 Ω
EFCT Input.....	< 10 Ω

Thermal Withstand:

1-A and 5-A Input:

Continuous .....	2 x CT Rating
1-Second .....	20 x CT Rating

EFCT Input:

Continuous .....	10 x CT Rating
1-Second .....	25 x CT Rating

Measurement Range .....25 x CT-Primary Rating

Trip Mode.....Latching/Non-Latching

Trip Relay K1 Contacts:

Configuration .....	N.O. (Form A)
Operating Mode .....	Fail-Safe or Non-Fail-Safe
CSA/UL Contact Ratings .....	8 A resistive 250 Vac, 5 A resistive 30 Vdc

Supplemental Contact Ratings:

Make/Carry 0.2 s.....30 A

Break:

dc.....	75 W resistive, 35 W inductive (L/R = 0.04 s)
ac.....	2,000 VA resistive, 1,500 VA inductive (PF = 0.4)

Subject to maximums of 8 A at 250 Vac, 5 A resistive at 30 Vdc, and 0.4 A resistive at 250 Vdc.

GF (K2) and RF (K3) Relay Contacts:

Configuration .....	N.O. and N.C. (Form C)
Operating Mode <sup>(5)</sup> .....	Non-Fail-Safe or Fail-Safe
CSA/UL Contact Ratings .....	8 A resistive 250 Vac, 8 A resistive 30 Vdc

Supplemental Contact Ratings:

Make/Carry 0.2s.....20 A

Break:

dc.....	50 W resistive, 25 W inductive (L/R = 0.04 s)
ac.....	2,000 VA resistive, 1,500 VA inductive (PF = 0.4)

Subject to maximums of 8 A at 250 Vac, 8 A resistive at 30 Vdc, and 0.4 A resistive at 150 Vdc.

Unit Healthy Output K4 (Option 0):

Configuration .....N.O. (Form A)  
 Operating Mode .....Closed when Healthy  
 Ratings .....100 mA, 250 V (ac or dc)  
 Closed Resistance .....30 to 50 Ω

Unit Healthy Output K4 (Option 1):

Configuration .....N.C. (Form B)  
 Operating Mode .....Open when Healthy  
 Ratings .....100 mA, 250 V (ac or dc)  
 Closed Resistance .....25 to 50 Ω maximum

Auto-reset time .....2.8 s maximum

4-20-mA Analog Output:

Type .....Self Powered and Loop Powered  
 Range .....4 to 22 mA  
 Loop Voltage .....8 to 36 Vdc  
 Load .....500 Ω (maximum with 24-Vdc supply)  
 Isolation .....120 Vac  
 Parameter .....NGR Current, 20 mA = CT Primary Current

USB Communications:

Baud Rate .....12 Mbit/s  
 Protocol .....USB Device  
 Connector .....Mini B

SD Memory Card:

Type .....Standard Grade  
 Form Factor .....microSD™<sup>(3)</sup> and microSDHC™<sup>(3)</sup>  
 Format .....FAT32  
 Capacity:  
 SE-330HV Hardware  
 Revision 16 and higher .....512 MB to 32 GB  
 SE-330HV Hardware  
 Revision 15 and lower .....512 MB to 4 GB

Operating Temperature:

Standard Grade  
 (Included) .....-25 to 85°C (-13 to 140°F)  
 Industrial Grade .....-40 to 85°C (-40 to 140°F)

PWB Conformal Coating .....MIL-1-46058 qualified, UL QMJU2 recognized

Mounting Configurations .....Panel Mount and Optional Surface Mount

Dimensions:

Height .....213 mm (8.4")  
 Width .....99 mm (3.9")  
 Depth .....132 mm (5.2")  
 Shipping Weight .....2.0 kg (4.4 lb)

Environment:

Operating Temperature .....-40 to 60°C (-40 to 140°F)  
 Storage Temperature .....-55 to 80°C (-67 to 176°F)  
 Humidity .....85% Non-Condensing  
 IP Rating .....IP30

Surge Withstand .....ANSI/IEEE C37.90.1-1989 (Oscillatory and Fast Transient)

EMC Tests:

Verification tested in accordance with IEC 60255-26:2013.

Radiated and Conducted

Emissions .....CISPR 11:2009, CISPR 22:2008, EN 55022:2010 Class A

Current Harmonics and

Voltage Fluctuations .....IEC 61000-3-2 and IEC 61000-3-3 Class A

Electrostatic Discharge .....IEC 61000-4-2

± 6 kV contact discharge (direct and indirect)  
 ± 8 kV air discharge

Radiated RF Immunity .....IEC 61000-4-3

10 V/m, 80-1,000 MHz, 80% AM (1 kHz)  
 10 V/m, 1.0 to 2.7 GHz, 80% AM (1 kHz)

Fast Transient .....IEC 61000-4-4

Zone B  
 ± 2 kV (power supply port), ± 1 kV (all other ports)

Surge Immunity .....IEC 61000-4-5

Zone B  
 ± 1 kV differential mode  
 ± 2 kV common mode

Conducted RF Immunity .....IEC 61000-4-6

10 V, 0.15-80 MHz, 80% AM (1 kHz)



Magnetic Field	
Immunity .....	IEC 61000-4-8 50 Hz and 60 Hz 30 A/m and 300 A/m
Power Frequency <sup>(4)</sup> .....	IEC 61000-4-16 Zone A: differential mode 100 Vrms Zone A: common mode 300 Vrms
1 MHz Burst .....	IEC 61000-4-18 ± 1 kV differential mode (line-to-line) ± 2.5 kV common mode
Voltage Interruption .....	IEC 61000-4-11, IEC 61000-4-29 0% for 10, 20, 30, 50 ms (dc) 0% for 0.5, 1, 2.5, 5 cycles (60 Hz) IEC 61000-4-17 Level 4, 15% of rated dc value

Certification .....CSA, Canada and USA



Australia



CE, European Union



FCC



To:CSA C22.2 No. 14 Industrial Control Equipment  
UL 508 Industrial Control Equipment  
UL 1053 Ground Fault Sensing and Relaying  
Equipment  
Australia, Regulatory Compliance Mark (RCM)  
CE Low Voltage Directive  
IEC 61010-1:2010 (3<sup>rd</sup> Edition) + AMD 1:2016  
FCC CFR47, Part 15, Subpart B,  
Class A – Unintentional Radiators

Compliance .....RoHS Pending

- (2) Accuracy included for EFCT-x and SE-CS30-x current sensors only.
- (3) microSD™ and microSDHC™ are trademarks of SD-3C, LLC.
- (4) Remote-reset wiring is limited to 10 m (32’).
- (5) This value can only be modified using SE-MON330 software. See Section 4.2.

**6.2 SENSING RESISTORS**

Environment:

Operating Temperature .....	-40 to 60°C (-40 to 140°F)
Storage Temperature .....	-55 to 80°C (-67 to 176°F)

ER-15KV:

Maximum Voltage .....	8,400 Vac
Maximum Current .....	84 mA
Resistance .....	100 kΩ
Thermal:	
8,400 Vac .....	1 minute on, 120 minutes off
1,900 Vac .....	Continuous
Torque (Terminal N) .....	9.0 N•m (80 lbf•in)
Shipping Weight .....	5.0 kg (11 lb)
Extended Operating Temperature .....	-55 to 60°C (-67 to 140°F) <sup>(1)</sup>

ER-25KV:

Maximum Voltage .....	14,400 Vac
Maximum Current .....	144 mA
Resistance .....	100 kΩ
Thermal:	
14,400 Vac .....	1 minute on, 120 minutes off
2,500 Vac .....	Continuous
Torque (Terminal N) .....	9.0 N•m (80 lbf•in)
Shipping Weight .....	20 kg (44 lb)
Extended Operating Temperature .....	-55 to 60°C (-67 to 140°F) <sup>(1)</sup>

ER-35KV:

Maximum Voltage .....	22,000 Vac
Maximum Current .....	220 mA
Resistance .....	100 kΩ
Thermal:	
22,000 Vac .....	1 minute on, 120 minutes off
3,000 Vac .....	Continuous
Torque (Terminal N) .....	9.0 N•m (80 lbf•in)
Shipping Weight .....	40 kg (88 lb)
Extended Operating Temperature .....	-55 to 60°C (-67 to 140°F) <sup>(1)</sup>

**NOTES:**

<sup>(1)</sup> See sensing resistor specifications for applicable voltage limits.

**ER-72KV:**

Maximum Voltage .....44,000 Vac  
 Maximum Current .....220 mA  
 Resistance .....200 kΩ  
 Thermal:  
     44,000 Vac .....1 minute on,  
   120 minutes off  
     6,000 Vac .....Continuous  
 Torque (Terminal N).....9.0 N•m (80 lbf•in)  
 Shipping Weight .....95 kg (210 lb)

**ER-1000HV:**

Maximum Voltage .....600 Vac  
 Maximum Current .....3 mA  
 Resistance .....200 kΩ  
 Thermal .....600 Vac Continuous  
 Shipping Weight .....300 g (0.7 lb)

Certification .....CSA, Canada and USA



UL Listed



Australia



CE, European Union



**NOTES:**

<sup>(1)</sup> Electrical specifications have been verified at a Littelfuse lab.

**6.3 CURRENT SENSORS**

**Environment:**

Operating Temperature .....-40 to 60°C (-40 to 140°F)  
 Storage Temperature .....-55 to 80°C (-67 to 176°F)

**EFCT-1:**

Current Ratio .....5:0.05 A  
 Insulation .....600-V Class  
 Window Diameter .....82 mm (3.2")  
 Shipping Weight .....0.9 kg (2.0 lb)  
 Certifications .....CSA, UL, CE  
 Compliance .....RoHS, IEC 60044-1  
 Extended Operating  
 Temperature .....-55 to 60°C  
   (-67 to 140°F)<sup>(1)</sup>

**Supplemental**

**Specifications:**

**Trip Level Accuracy:**

≤ 1 A .....1% of CT-Primary Rating  
 > 1 A .....3% of CT-Primary Rating

**EFCT-26:**

Current Ratio .....5:0.05 A  
 Insulation .....600-V Class  
 Window Diameter .....26 mm (1.0")  
 Shipping Weight .....0.45 kg (1.0 lb)  
 Certifications .....CSA, UL, CE  
 Compliance .....RoHS, IEC 60044-1  
 Extended Operating  
 Temperature .....-55 to 60°C  
   (-67 to 140°F)<sup>(1)</sup>

**Supplemental**

**Specifications:**

**Trip Level Accuracy:**

≤ 1 A .....1% of CT-Primary Rating  
 > 1 A .....3% of CT-Primary Rating

**SE-CS30-26:**

Current Ratio .....30:0.05 A  
 Insulation .....600-V Class  
 Window Diameter .....26 mm (1.0")  
 Shipping Weight .....0.45 kg (1.0 lb)  
 Certifications .....CSA, UL, CE  
 Compliance .....RoHS, IEC 60044-1  
 Extended Operating  
 Temperature .....-55 to 60°C  
   (-67 to 140°F)<sup>(1)</sup>

**SE-CS30-70:**

Current Ratio .....30:0.05 A  
 Insulation .....600-V Class  
 Window Diameter .....70 mm (2.7")  
 Shipping Weight .....1.2 kg (2.5 lb)  
 Certifications .....CSA, UL, CE  
 Compliance .....RoHS, IEC 60044-1  
 Extended Operating  
 Temperature .....-55 to 60°C  
   (-67 to 140°F)<sup>(1)</sup>

**CT200:**

Current Ratio .....200:5 A  
 Insulation .....600-V Class  
 Window Diameter .....56 mm (2.2")  
 Shipping Weight .....1 kg (2.2 lb)  
 Certifications .....CSA, UL  
 Compliance .....RoHS  
 Extended Operating  
 Temperature .....-55 to 60°C  
   (-67 to 140°F)<sup>(1)</sup>

**NOTES:**

<sup>(1)</sup> Electrical specifications have been verified at a Littelfuse lab.

**7. ORDERING INFORMATION**

**SE-330HV-** 

- K4 Contact:
  - 0 N.O. UNIT HEALTHY Contact
  - 1 N.C. UNIT HEALTHY Contact
- Options:
  - 0 No Options
- Network Communications:<sup>(1)</sup>
  - 0 None
  - 1 DeviceNet™
  - 3 Ethernet (Dual RJ45)<sup>(2)</sup>
  - 4 Ethernet (SC Fiber & RJ45)<sup>(2)</sup>
  - 5 Ethernet (Dual SC Fiber)<sup>(2)</sup>
  - 6 IEC 61850 (Dual RJ45)<sup>(3)</sup>
  - 7 IEC 61850 (SC Fiber & RJ45)<sup>(3)</sup>
  - 8 IEC 61850 (Dual SC Fiber)<sup>(3)</sup>
- Supply:
  - 0 Universal ac/dc Supply
  - 2 48 Vdc Supply

**NOTE:** Please refer to the SE-330 Product Change Notice (PCN) document for updated ordering information and new revision details, available at [www.littelfuse.com/se-330hv](http://www.littelfuse.com/se-330hv).

**NOTE:** The SE-330-SMA Surface Mount Adapter is available as an accessory only.

**Sensing Resistors:**

- ER-15KV .....For system voltages up to 15 kVac
- ER-25KV .....For system voltages up to 25 kVac
- ER-35KV .....For system voltages up to 35 kVac
- ER-72KV .....For system voltages up to 72 kVac
- ER-1000HV .....For system voltages up to 1 kVac

**Current Sensors:**

- EFCT-1.....Current Sensor, 5-A-primary rating, 82 mm (3.2”) window, 6 m (19.5’) of 22 AWG (3.3 mm<sup>2</sup>) shielded cable included
- EFCT-26.....Current Sensor, 5-A-primary rating, 26 mm (1.0”) window, 6m (19.5’) of 22 AWG (3.3 mm<sup>2</sup>) shielded cable included
- SE-CS30-26 .....Current Sensor 30-A-primary rating, 26 mm (1.0”) window

- SE-CS30-70.....Current Sensor, 30-A-primary rating, 70 mm (2.7”) window
- CT200 .....Current Sensor, 200-A-primary rating, 56 mm (2.2”) window
- 5SHT-101-E .....Current Sensor, 100-A-primary rating, 40 mm (1.6”) window
- 5SHT-151-E .....Current Sensor, 150-A-primary rating, 40 mm (1.6”) window
- 5SHT-500-E .....Current Sensor, 50-A-primary rating, 40 mm (1.6”) window
- 7SHT-301-E .....Current Sensor, 300-A-primary rating, 64 mm (2.5”) window
- 7SHT-401-E .....Current Sensor, 400-A-primary rating, 64 mm (2.5”) window

**Accessories:**

- RK-332 .....Remote Indication and Reset, includes two 120-V pilot lights, a reset push button, and legend plates
- SE-IP65CVR-G.....Hinged transparent cover, IP65
- PGA-0520.....Percent Analog Meter
- SE-330-SMA .....Surface Mount Adapter
- AC300-MEM-00.....Industrial-Grade microSD™ Card

**Software:** <sup>(4)</sup>

- SE-MON330 Software .....SE-330HV Data-Display Program for PC, version 3.5 or newer
- NGR Monitor
- Set-Point Assistant .....Setting Guide

**NOTES:**

- <sup>(1)</sup> Profibus models only available on legacy SE-330HV.
- <sup>(2)</sup> Includes Modbus TCP and Ethernet/IP protocols.
- <sup>(3)</sup> Includes IEC 61850 and Modbus TCP protocols.
- <sup>(4)</sup> Available at [www.littelfuse.com/relayscontrols](http://www.littelfuse.com/relayscontrols).

## 8. WARRANTY

The SE-330HV Neutral-Grounding-Resistor Monitor is warranted to be free from defects in material and workmanship for a period of five years from the date of purchase.

Littelfuse Startco will (at Littelfuse Startco's option) repair, replace, or refund the original purchase price of an SE-330HV that is determined by Littelfuse Startco to be defective if it is returned to the factory, freight prepaid, within the warranty period. This warranty does not apply to repairs required as a result of misuse, negligence, an accident, improper installation, tampering, or insufficient care. Littelfuse Startco does not warrant products repaired or modified by non-Littelfuse Startco personnel.

## 9. TEST PROCEDURES

**NOTE:** Ensure the real-time clock is set. See Section 4.2.

### 9.1 RESISTOR-FAULT TESTS

Perform tests with system de-energized and supply voltage applied to the SE-330HV.

#### 9.1.1 CALIBRATION AND OPEN TEST

Test Equipment: 100-k $\Omega$  and 200-k $\Omega$ , 1/4-watt, 1% calibration resistors (calibration resistors supplied with SE-330HV).

Procedure:

- Remove connections to terminals 6 and 7.
- Connect the 100-k $\Omega$  resistor to terminals 6 and 7.
- Set switch S5 to the 100-k $\Omega$  position.
- Perform calibration as per Section 2.2.
- The CALIBRATED LED should be on. Press RESET.
- Remove the 100-k $\Omega$  resistor and wait for the resistor-fault trip time.

**PASS:** The SE-330HV should trip on resistor fault.

- Connect the 200-k $\Omega$  resistor to terminals 6 and 7.
- Set switch S5 to the 200-k $\Omega$  position.
- Perform calibration as per Section 2.2.
- The CALIBRATED LED should be on.
- Press RESET.
- Remove the 200-k $\Omega$  resistor and wait for the resistor-fault trip time.

**PASS:** The SE-330HV should trip on resistor fault.

**NOTE:** Resistor-fault-trip reset can take up to one second.

#### 9.1.2 VOLTAGE TEST

Test Equipment: 0 to 250 Vac voltage source, multimeter, and ER sensing resistor.

**NOTE:** Use an isolation transformer if the test-voltage source does not provide dc continuity for the SE-330HV resistance-measuring circuit.

**NOTE:** Applying the test voltage to the R and G terminals will damage the SE-330HV and the ER sensing resistor. The  $V_N$  TRIP LEVEL is the trip voltage at terminal N, not terminal R.

Procedure:

- Connect the ER sensing resistor to the SE-330HV and calibrate the SE-330HV.
- Disconnect the wire from sensing-resistor terminal N. A resistor-fault will occur.
- Set the voltage source to 0 V.
- Connect the voltage source between sensing resistor N and G terminals.
- Set the  $V_N$  TRIP LEVEL (VAC) to 100.
- Press RESET.
- The RESISTOR FAULT TRIP LED should be off.
- Increase the test voltage to 120 Vac for 100-k $\Omega$  sensors or 240 Vac for 200-k $\Omega$  sensors and wait the resistor-fault trip time.

**PASS:** The SE-330HV should trip on RESISTOR FAULT. A time-delayed ground-fault trip follows the resistor-fault trip if neutral voltage persists after the resistor fault. For legacy units with firmware revision 6 or less, this does not apply.

### 9.2 SENSING-RESISTOR TEST

Test Equipment: Multimeter.

Procedure:

- Disconnect the sensing resistor.
- Measure the resistance between sensing-resistor terminals R and N.
- **PASS:** Resistance should be between 98 and 102 k $\Omega$  for 100-k $\Omega$  sensing resistors. Resistance should be between 196 and 204 k $\Omega$  for 200-k $\Omega$  sensing resistors.
- Measure the resistance between sensing-resistor terminals R and G in both directions.

**PASS:** Resistance should be greater than 10 M $\Omega$  in both directions.

### 9.3 ANALOG-OUTPUT TEST

Test Equipment: Multimeter with a mAdc scale.

Procedure:

- Connect the 4–20-mA output as a self-powered output as shown in Fig. 3. Measure the current from terminal 20 to terminal 21.
- **PASS:** With no CT current, the analog output should be 4 mA.
- Output is linear to 20 mA. Output is 20 mA when CT-primary current is equal to the CT-primary rating.

**9.4 GROUND-FAULT PERFORMANCE TEST**

To meet the requirements of the National Electrical Code (NEC), as applicable, the overall ground-fault protection system requires a performance test when first installed. A written record of the performance test is to be retained by those in charge of the electrical installation in order to make it available to the authority having jurisdiction. A test-record form is provided for recording the date and the final results of the performance tests. The following ground-fault system tests are to be conducted by qualified personnel:

- a) Evaluate the interconnected system in accordance with the overall equipment manufacturer’s detailed instructions.
- b) Verify proper installation of the ground-fault current sensor. Ensure the cables pass through the ground-fault-current-sensor window. This check can be done visually with knowledge of the circuit. The connection of the current-sensor secondary to the SE-330HV is not polarity sensitive.
- c) Verify that the system is correctly grounded and that alternate ground paths do not exist that bypass the current sensor. High-voltage testers and resistance bridges can be used to determine the existence of alternate ground paths.
- d) Verify proper reaction of the circuit-interrupting device in response to a simulated or controlled ground-fault current. To simulate ground-fault current, use CT-primary current injection (does not apply for bushing-type CT’s). Fig. 21 shows a test circuit using an SE-400 Ground-Fault-Relay Test Unit. The SE-400 has a programmable output of 0.5 to 9.9 A for a duration of 0.1 to 9.9 seconds. Set the test current to 120% of GF TRIP LEVEL. Inject the test current through the current-sensor window for at least 2.5 seconds. Verify that the circuit under test has reacted properly. Correct any problems and re-test until the proper reaction is verified.
- e) Record the date and the results of the test on the attached test-record form.

**NOTE:** Do not inject test current directly into CT-input terminals 8, 9, 10, and 11.

**NOTE:** For accurate trip-time measurement, the fault current should not be re-applied for the time defined by the GF TRIP TIME setting to allow the trip accumulator to initialize.

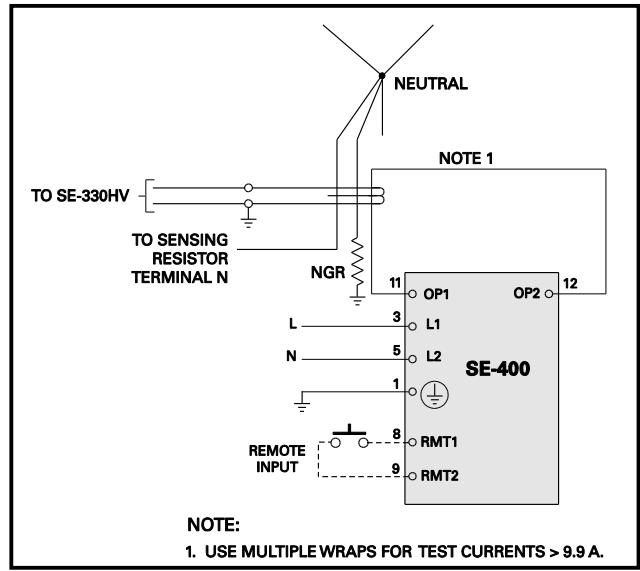

FIGURE 21. Ground-Fault-Test Circuit.

TABLE 3. GROUND-FAULT-TEST RECORD

DATE	TEST RESULTS

Retain this record for the authority having jurisdiction.

**APPENDIX A  
SE-330HV REVISION HISTORY**

<b>MANUAL RELEASE DATE</b>	<b>MANUAL REVISION</b>	<b>HARDWARE REVISION (REVISION NUMBER ON PRODUCT LABEL)</b>	<b>FIRMWARE REVISION</b>
October 18, 2017	5-M-101817	17	2.60
December 7, 2016	5-L-120716	16	2.55
September 21, 2016	5-K-092116		2.54
June 30, 2016	5-J-063016		2.53
September 11, 2015	5-I-091115		2.52
June 22, 2015	5-H-062215	15	2.50
May 20, 2015	5-G-052015		2.40
March 3, 2015	5-F-030315		
July 8, 2014	5-E-070814	14	2.31 2.30
April 14, 2014	5-D-041414	13	2.20
January 9, 2014	5-C-010914	12	
		11	
November 29, 2013	5-B-112913	10A	2.10
October 8, 2013	5-A-100813	10A	2.08

**MANUAL REVISION HISTORY**

**REVISION 5-M-101817**

**SECTION 2**

New features described in Section 2.7.

**SECTION 3**

Updated installation instructions.

**SECTION 4**

SD Card note added.

**SECTION 5**

Troubleshooting information added.

**SECTION 7**

Ordering information updated.

**REVISION 5-L-120716**

**APPENDIX A**

Revision history updated.

**REVISION 5-K-092116**

**SECTION 4**

Updated firmware upgrade instructions.

**APPENDIX A**

Revision history updated.

**REVISION 5-J-063016**

**SECTION 4**

Section 4.1.2 updated.

**SECTION 6**

microSD™ storage capacity increased to 32 GB.

RCM certification added.

**REVISION 5-I-091115**

**SECTION 4**

Section 4.1.2 updated.

**SECTION 5**

SD card diagnostic troubleshooting updated.

**REVISION 5-H-062215**

**SECTION 2**

Section 2.1.6 added.

**SECTION 4**

SD Card approximate yearly data logging usage updated.  
SE-MON330 software version updated.

**SECTION 6**

Resistor-fault trip level ranges added.

**REVISION 5-G-052015**

**SECTION 4**

SD Card storage capacity updated.

**SECTION 6**

SD Card storage capacity specification updated.

**REVISION 5-F-030315**

**SECTION 2**

Sections 2.1.5 and 2.1.6 added.

**SECTION 4**

Section 4.2 new features added.

**SECTION 6**

Resistor-fault circuit trip time updated.

**REVISION 5-E-070814**

**SECTION 6**

Added CE, C-Tick, and FCC information.

**REVISION 5-D-041414**

**APPENDIX A**

Hardware revision updated.

**REVISION 5-C-010914**

**SECTION 6**

Extended operating temperatures added to the ER-15KV, ER-25KV,  
and ER-35KV sensing resistors and SE-CS30  
current sensors.

**REVISION 5-B-112913**

**SECTION 6**

CE added to sensing resistors.

**SECTION 7**

Ordering information updated.

**REVISION 5-A-100813**

**SECTION 1**

Faceplate updated.  
New features added.

**SECTION 2**

Communications options updated.  
Configuration switches updated.  
Indication relays explanation added.  
Non-volatile-memory error added.

**SECTION 3**

Connection drawing updated.

**SECTION 4**

Section heading changed to Data Interfaces.  
Updated with microSD™ and USB interfaces.  
Upgrade procedure added.  
Real Time Clock note added in Section 4.2.

**SECTION 5**

Non-volatile-memory error added.  
Switch S8 diagnostic LED error removed.

LED and relay status added to troubleshooting solutions.

#### **SECTION 6**

Ground-fault circuit trip level updated.  
USB communications specifications added.  
Resistor-fault accuracy changed.  
microSD™ memory card specifications added.

#### **SECTION 7**

Ordering information updated.  
SE-330-SMA Surface Mount Adapter is now listed as an accessory only.

#### **APPENDIX A**

Added revision history.

### **HARDWARE REVISION HISTORY**

#### **HARDWARE REVISION 17**

Enhanced transient protection added.

#### **HARDWARE REVISION 16**

microSD™ storage capacity increased to 32 GB.

#### **HARDWARE REVISION 15**

RTC circuit updated.

#### **HARDWARE REVISION 14**

Added CE and C-Tick compliance.

#### **HARDWARE REVISION 13**

Reduced ESD sensitivity of front-panel dials.

#### **HARDWARE REVISION 12**

Improved Fiber Ethernet support.

#### **HARDWARE REVISION 11**

Reduced ESD sensitivity of USB and SD card connectors.

#### **HARDWARE REVISION 10A**

Updated SE-330HV platform to include USB and microSD™ interfaces, programmable trip level (MEM) feature, and ability to add future options.  
Real-time clock added.  
Added dual cable and fiber Ethernet ports.  
Update to RTC circuit.

### **FIRMWARE REVISION HISTORY**

#### **FIRMWARE REVISION 2.60**

Added option to display only critical diagnostic codes with DIAGNOSTIC LED.

#### **FIRMWARE REVISION 2.55**

Corrected IEC 61850 Network watchdog resets.

#### **FIRMWARE REVISION 2.54**

NAND FLASH bit-error-correction update to prevent solid-red diagnostic LED error when bit errors are correctable.  
Resistor-Fault Trip Level added to web interface.  
Corrected MODBUS® TCP/IP write response byte count.  
TCP Keep Alive network setting no longer resets to 5s after power cycle.

#### **FIRMWARE REVISION 2.53**

Fixed NAND FLASH bit error correction code to prevent solid-red diagnostic error.

#### **FIRMWARE REVISION 2.52**

Improved compatibility with Internet Explorer™ web browser.

#### **FIRMWARE REVISION 2.50**

Added support for adjustable resistor-fault trip level.  
Web page functionality re-enabled for Ethernet options.

#### **FIRMWARE REVISION 2.40**

Added support for geo-magnetic filter.  
Added support for 12 to 60 s resistor-fault trip time.  
Improved log file descriptions.



IEC 61850 GOOSE network input support now always enabled.  
Improved compatibility for Modbus TCP.  
Web page disabled for Ethernet options. This will be enabled in a future firmware release.  
IP setting changes for Ethernet options now require power cycle to take effect.

**FIRMWARE REVISION 2.31**

SD Card and USB diagnostic events no longer cause a trip.

**FIRMWARE REVISION 2.30**

Remote calibration feature added.

**FIRMWARE REVISION 2.20**

Added support for EtherNet/IP protocol.  
IED name now reported correctly through IEC 61850 interface.  
EtherNet/IP and Modbus communications card LED status updated.  
Hardware version viewable in the SE-MON330 software and through the Modbus and IEC 61850 servers.

**FIRMWARE REVISION 2.10**

Added support for IEC 61850 and DeviceNet protocols.

**FIRMWARE REVISION 2.08**

Updated firmware to include USB and microSD™ interfaces, datalogging, and firmware update via microSD™.  
K2 and K3 indication relays can be configured for fail-safe or non-fail-safe operation.  
Trip records increased to 100 with date and time stamping.  
Added support for communications options.

This page intentionally left blank.